

SEG-D, Rev 3.0
SEG Field Tape Standards
May, 2011

Table of Contents

| | | |
|------------|----------------------------------------------------------------------|-----------|
| 1.0 | INTRODUCTION..... | 5 |
| 1.1 | CONTROLLING ORGANIZATION..... | 6 |
| 2.0 | CHANGES INTRODUCED IN REVISION 3.0 | 7 |
| 2.1 | CHANGES INTRODUCED IN REVISION 2.1..... | 10 |
| 2.2 | CHANGES INTRODUCED IN REV 2.0 | 11 |
| 2.3 | CHANGES INTRODUCED IN REV 1 | 13 |
| 3.0 | FORMAT OVERVIEW | 17 |
| 3.1 | SEG-D TIMESTAMP..... | 25 |
| 3.2 | MULTI-COMPONENT DATA..... | 27 |
| 3.3 | EXTENDED RECORDING MODE | 28 |
| 3.4 | PERMANENT RECORDING SYSTEMS | 28 |
| 3.5 | TIME DRIFT | 29 |
| 3.6 | POSITIONS IN SEG-D | 29 |
| 4.0 | SEG-D, REV 3.0 STRUCTURE | 31 |
| 4.1 | REV 3.0 STORAGE UNIT LABEL (TAPE LABEL) | 31 |
| 4.2 | REV 3.0 TABLE OF CONTENTS (TOC) FILE (OPTIONAL)..... | 33 |
| 4.2.1 | TOC Header | 34 |
| 4.2.2 | TOC Record Entry | 36 |
| 4.2.3 | Using the TOC with SEG-D on disk..... | 37 |
| 5.0 | HEADER BLOCKS..... | 39 |
| 5.1 | GENERAL HEADERS (GENERAL HEADER BLOCK #1, #2 AND #3 ARE REQUIRED) .. | 39 |
| 5.2 | SCAN TYPE HEADERS | 41 |
| 5.3 | DEMUX TRACE HEADER (REQUIRED) | 42 |
| 5.4 | EXTENDED HEADER (OPTIONAL) | 44 |
| 5.5 | EXTERNAL HEADER (OPTIONAL) | 44 |
| 5.6 | GENERAL TRAILER (OPTIONAL)..... | 44 |
| 5.6.1 | Edit (SEG-D Trace Edit v1.0)..... | 44 |
| 5.6.2 | Navigation data backup..... | 47 |
| 5.6.3 | Text Comment..... | 47 |
| 5.6.4 | Observer log | 48 |
| 5.6.5 | User defined | 48 |
| 6.0 | DATA BODY..... | 49 |
| 6.1 | DATA RECORDING METHOD | 49 |
| 6.2 | DSM FACTOR CALCULATION AND PHYSICAL UNIT | 54 |
| 6.3 | SENSOR CALIBRATION..... | 56 |
| 7.0 | HEADER TABLES..... | 58 |
| 7.1 | GENERAL HEADER BLOCK #1 | 58 |
| 7.2 | GENERAL HEADER BLOCK #2 | 59 |
| 7.3 | GENERAL HEADER BLOCK #3 (TIMESTAMP AND SIZE HEADER) | 60 |
| 7.4 | GENERAL HEADER BLOCK #4 (VESSEL/CREW IDENTIFICATION) (OPTIONAL) .. | 60 |
| 7.5 | GENERAL HEADER BLOCK #5 (SURVEY AREA NAME) (OPTIONAL)..... | 61 |
| 7.6 | GENERAL HEADER BLOCK #6 (CLIENT IDENTIFICATION) (OPTIONAL).... | 62 |
| 7.7 | GENERAL HEADER BLOCK #7 (JOB IDENTIFICATION) (OPTIONAL) | 63 |
| 7.8 | GENERAL HEADER BLOCK #8 (LINE IDENTIFICATION) (OPTIONAL) | 64 |

| | | | |
|------------|----------------------------------------------------------------------|-----------|----|
| 7.9 | SOURCE DESCRIPTION BLOCK (OPTIONAL)..... | 64 | |
| 7.9.1 | VIBRATOR..... | 65 | |
| 7.9.2 | EXPLOSIVE | 65 | |
| 7.9.3 | AIRGUN..... | 66 | |
| 7.9.4 | WATERGUN | 67 | |
| 7.9.5 | ELECTROMAGNETIC SOURCE..... | 68 | |
| 7.9.6 | OTHER SOURCE | 69 | |
| 7.10 | ADDITIONAL SOURCE INFO (OPTIONAL)..... | 69 | |
| 7.11 | SOURCE AUXILIARY CHANNEL REFERENCE (OPTIONAL) | 70 | |
| 7.12 | COORDINATE REFERENCE SYSTEM IDENTIFICATION (CONDITIONAL)..... | 72 | |
| 7.13 | POSITION BLOCKS (OPTIONAL)..... | 72 | |
| 7.14 | RELATIVE POSITION BLOCK (OPTIONAL)..... | 75 | |
| 7.15 | SCAN TYPE HEADER (CHANNEL SET DESCRIPTOR)..... | 75 | |
| 7.16 | DEMUX TRACE HEADER..... | 79 | |
| 7.17 | TRACE HEADER EXTENSION #1 | 80 | |
| 7.18 | SENSOR INFO HEADER EXTENSION (OPTIONAL)..... | 80 | |
| 7.19 | TIMESTAMP HEADER (OPTIONAL) | 81 | |
| 7.20 | SENSOR CALIBRATION HEADER (OPTIONAL) | 82 | |
| 7.21 | TIME DRIFT HEADER (OPTIONAL) | 83 | |
| 7.22 | ORIENTATION HEADER (OPTIONAL) | 83 | |
| 7.23 | MEASUREMENT BLOCK (OPTIONAL)..... | 84 | |
| 7.24 | ELECTROMAGNETIC SRC/RCV DESC BLOCK (OPTIONAL)..... | 85 | |
| 7.25 | GENERAL TRAILER DESCRIPTION BLOCK (OPTIONAL)..... | 86 | |
| 8.0 | HEADER BLOCK PARAMETERS | 88 | |
| 8.1 | GENERAL HEADER, BLOCK #1 | 88 | |
| 8.2 | GENERAL HEADER BLOCK #2 | 90 | |
| 8.3 | GENERAL HEADER BLOCK #3 (TIMESTAMP AND SIZE HEADER) | 92 | |
| 8.4 | GENERAL HEADER BLOCK #4 (VESSEL/CREW IDENTIFICATION) (OPTIONAL)..... | 93 | 93 |
| 8.5 | GENERAL HEADER BLOCK #5 (SURVEY AREA NAME) (OPTIONAL)..... | 93 | |
| 8.6 | GENERAL HEADER BLOCK #6 (CLIENT IDENTIFICATION) (OPTIONAL).... | 94 | |
| 8.7 | GENERAL HEADER BLOCK #7 (JOB IDENTIFICATION) (OPTIONAL) | 94 | |
| 8.8 | GENERAL HEADER BLOCK #8 (LINE IDENTIFICATION) (OPTIONAL) | 94 | |
| 8.9 | SOURCE DESCRIPTION BLOCK (OPTIONAL)..... | 95 | |
| 8.9.1 | VIBRATOR | 95 | |
| 8.9.2 | EXPLOSIVE..... | 97 | |
| 8.9.3 | AIRGUN | 99 | |
| 8.9.4 | WATERGUN..... | 101 | |
| 8.9.5 | ELECTROMAGNETIC..... | 102 | |
| 8.9.6 | OTHER SOURCE..... | 104 | |
| 8.10 | ADDITIONAL SOURCE INFO (OPTIONAL)..... | 106 | |
| 8.11 | SOURCE AUXILIARY CHANNEL REFERENCE (OPTIONAL) | 106 | |
| 8.12 | COORDINATE REFERENCE SYSTEM IDENTIFICATION (CONDITIONAL)..... | 108 | |
| 8.13 | POSITION BLOCKS (OPTIONAL)..... | 108 | |
| 8.14 | RELATIVE POSITION BLOCK (OPTIONAL)..... | 111 | |
| 8.15 | SCAN TYPE HEADER (CHANNEL SET DESCRIPTOR) | 111 | |
| 8.16 | CHANNEL SET DESCRIPTOR..... | 112 | |
| 8.17 | DEMUX TRACE HEADER..... | 116 | |
| 8.18 | TRACE HEADER EXTENSION #1 | 117 | |
| 8.19 | SENSOR INFO HEADER EXTENSION (OPTIONAL)..... | 119 | |
| 8.20 | TIMESTAMP HEADER (OPTIONAL) | 119 | |
| 8.21 | SENSOR CALIBRATION HEADER (OPTIONAL) | 120 | |

| | | |
|--------------------------------------------------------------------|-------------------------------------------------------------------------------------------------------|------------|
| 8.22 | TIME DRIFT HEADER (OPTIONAL) | 120 |
| 8.23 | ORIENTATION HEADER (OPTIONAL) | 121 |
| 8.24 | MEASUREMENT BLOCK (OPTIONAL) | 124 |
| 8.25 | ELECTROMAGNETIC SRC/RECV DESC BLOCK (OPTIONAL) | 125 |
| 8.26 | GENERAL TRAILER (OPTIONAL) | 126 |
| 8.26.1 | GENERAL TRAILER DESCRIPTION BLOCK (optional) | 126 |
| APPENDIX A: MANUFACTURERS OF SEISMIC FIELD RECORDERS | | 128 |
| APPENDIX B: GLOSSARY | | 132 |
| APPENDIX C: API PRODUCER ORGANIZATION CODE..... | | 134 |
| APPENDIX D: COORDINATE REFERENCE SYSTEM IDENTIFICATION | | 138 |
| D.1 | LOCATION DATA | 138 |
| D.1.1 | Location Data stanza..... | 139 |
| D.1.2 | Example Stanzas for Location Data..... | 146 |
| D.1.3 | Location Data Coordinate Transformation stanzas..... | 151 |
| D.1.4 | Example Stanzas for Location Data Transformation | 158 |
| APPENDIX E: EXAMPLES AND CALCULATIONS | | 160 |
| E.1 | SAMPLES PER SCAN TYPE..... | 160 |
| E.2 | SKREW FIELDS PER SCAN TYPE | 160 |
| E.3 | FILTER SLOPE CALCULATION..... | 161 |
| E.4 | SEG-D FILE STORAGE ON NON-TAPE MEDIA | 161 |
| E.5 | SEG-D RECORD INDEX INTERPRETATION FOR MARINE, LAND, SEABED, TRANSITION-ZONE, AND VSP SURVEYS | 162 |
| E.6 | TRACE EDIT EXAMPLE | 165 |
| E.7 | SOURCE INFORMATION IN GENERAL HEADER OR TRACE HEADER..... | 166 |
| E.8 | EXTENDED RECORDING MODE EXAMPLE | 168 |
| E.9 | SEG-D TIMESTAMP CALCULATION | 169 |
| E.10 | ELECTROMAGNETIC (EM) SURVEY | 174 |
| E.11 | EXTENDED RECORDING MODE 2 | 177 |

1.0 Introduction

For several years now there has been talk of the need for a new revision of the SEG-D standard for seismic field data. The last major revision of the standard, Rev 2.0, was published in 1996 with an incremental update Rev 2.1 in 2006. This new Revision 3.0 recognizes the significant developments in acquisition and computer technologies and brings the standard into line with current, and many envisioned future, industry techniques and practices. It also resolves longstanding ambiguities and corrects both typographic and factual errors that have been reported against the existing SEG-D standards. (It does not, we admit, contain the prescription for RODE encapsulation promised in the Rev 2.0 introduction. It has been decided to keep the mapping of seismic data to RODE separate from the SEG-D format.) While not fully 100% backwards compatible to prior revisions, the only significant changes required to existing software that creates SEG-D output is the generation of a third General Header block, and updating the channelset descriptors to 96 bytes. Most other additions are optional.

Among the major upgrades that can be encoded in new header and trailer blocks are microsecond accurate timestamps, detailed source and sensor (multicomponent included) description, extended recording modes that allow for nearly 9 years of continuous recording by permanent emplacements, electromagnetic survey support, post-acquisition edits, coordinate reference system datum and projection, microsecond sample rates, and negative start times.

At the SEG convention in Houston in 2005, the SEG Technical Standards Committee decided to revive the SEG-D Format Subcommittee, with Stewart A. Levin of Halliburton Energy Services, whose passions include maintenance and improvement of SEG-D input software packages, volunteering to chair the subcommittee and provide the necessary energy to drive it forward. Since then there has been considerable activity to ascertain what should be contained in the new revision, with email discussion lists, subcommittee activities, progress reports in *The Leading Edge* and *First Break*, and meetings of interested parties at the EAGE and SEG annual meetings. This updated standard explicitly incorporates items and codes from the industry standards groups such as Energistics and the International Association of Oil and Gas Producers (OGP).

The following individuals have been active participants in this effort:

| | | |
|------------------|--------------------------|--------------------------------|
| Jill Lewis | Troika International | Technical Standards Chair |
| Stewart A. Levin | Halliburton | SEG-D Subcommittee Chair |
| Rune Hagelund | Roxar | Technical Standards Vice Chair |
| Barry D. Barrs | ExxonMobil | |
| Roger Lott | Consultant | |
| Tore Nilsen | Schlumberger WesternGeco | |
| Francois Daube | Schlumberger WesternGeco | |
| Paul Maton | Sillimanite Consultants | |
| Nils Aatland | Fugro Seismic Imaging | |
| Jacques Hamon | Sercel | |
| Angus Stott | Petroleum Geo-Services | |
| Peter Green | Saudi Aramco | |
| Joseph Cignoli | Saudi Aramco | |
| Bob Firth | Troika International | |

Numerous other people have also participated at various times.

1.1 Controlling Organization

The SEG-D rev 3.0 is administered by the SEG Technical Standards Committee. Any questions, corrections or problems encountered in the format should be addressed to:

Society of Exploration Geophysicists
P.O. Box 702740
Tulsa, Ok 74170-2740

Attention: SEG Technical Standards Committee
Phone: (918) 497-5500
Fax: (918) 497-5557
Internet site: www.seg.org

2.0 Changes Introduced in Revision 3.0

Revision 3.0 introduces format changes to better handle the requirements from modern seismic acquisition and processing systems. Revision 3.0 attempts to be an improved format for information exchange between the data acquisition and processing system by including important metadata like equipment positions and trace edits.

The following list is a summary of the specific changes made in Revision 3.0 compared to 2.1:

1. Revision number changed from 2.1 to 3.0, see
 - a. Chapter 4.1 (Storage Unit Label, field number 2), and
 - b. Chapter 8.2 (General Header #2, byte 11 and 12).
2. The following headers are left mostly unchanged to allow e.g. pattern matching, i.e. searching for recognizable patterns in a stream of data. The minor changes are:
 - a. Tape Label (updated the SEG-D version number),
 - b. General Header #1 (allow FF₁₆ as value of byte 23, to support different base scan intervals), and
 - c. Demux Trace Header (allow FFFF₁₆ as value in bytes 5 and 6, to support extended trace number).
3. Rev 3.0 no longer requires a channel set to be present, making it possible to store a SEG-D record without any data. This supports creating a SEG-D record with only header data, e.g. only External, Extended, and/or General Trailer, which is useful for transferring metadata between systems.
4. Rev. 3.0 allows traces of zero length (no samples). This is done by setting start and end time to the same value, and setting number of samples to 0 (Byte 13–16 of Channel Set Descriptor). This supports transfer of Trace Header meta data between systems without any data attached.
5. Rev 3.0 is still a shot domain format; however a separate mode, Extended Recording Mode, has been added to partially support non-shot domain data.
6. A high-resolution timestamp is introduced to accurately determine the time in SEG-D. The time of first sample in record is entered in General Header #3 (Bytes 1–8). Position measurements, orientation measurements, source events, etc. all have a timestamp attached, which allows multiple measurements of the same type to be stored within the same record and trace header. This gives the manufacturer a much more fine grained control over, for example, the movement of equipment during the record, and allows the use of modern, more powerful filtering techniques to be applied to the data traces.
7. A SEG-D positioning format has been defined, and Position blocks may be inserted into Trace Headers. The datum and projection information is inserted as part of the General Header. A single SEG-D record should only contain one datum/projection, though a second geographic coordinate system (with same datum) may also be used. Multiple datums/projections may exist for a given storage unit (tape), however it is recommended to not vary the coordinate system definitions as this increases the likelihood of errors in usage of the data.
8. Rev 3.0 has an extended indexing structure, allowing more advanced logical addressing of traces, and better grouping of information. The following indexes are supported for sources and receivers: Line, Point, Point Index, Depth, Group and Re-shoot index.
9. An orientation header has been defined to properly support multi-component data. The format supports rotation to a global reference system as part of acquisition, or to be applied later in processing. The rotation specified in the orientation header may or may not be applied as part of acquisition. The Trace type and Line, Point and Group indexes are used to determine which traces should be rotated together.

10. Rev 3.0 supports an increased range of sampling intervals, record lengths, number of channels, filter resolution, etc. compared to Rev 2.x, to be able to handle the requirements of modern acquisition systems. In addition negative times for start of trace are now supported.
11. The size of header, data, record etc. are now explicitly stated in General Header to facilitate quick data access and facilitate error recovery.
12. All header blocks have an enumerated type attached (byte 32 of all blocks), both to increase flexibility of the format to and simplify decoding. This also allows all information to be optional, simplifies error recovery and increases the robustness of the format. In addition, it allows information to be inserted in the header and order deemed most useful by the recorder.
13. The Channel Set Header has been extended to 96 bytes to support extended sampling intervals, trace lengths, etc. All values are now explicitly stated, no complex calculation is required to determine, e.g., sampling interval or descale multiplier. In addition derived values, such as the number of samples per channel, are also explicitly stated to avoid ambiguities of prior versions of the SEG-D standard. A recorder-defined textual description has been added to the channel set descriptor to increase the flexibility of the storage format and increase the efficiency of information transfer between acquisition and processing.
14. The number of channels per channel set has been extended to 16,777,215.
15. General Header blocks for common acquisition information like Client, Job, Survey Area, Vessel/Crew and Line information have been defined. The information in these General Header blocks is intended to be a short, textual description of the specific item, not a complete, detailed description. To give a complete definition of the survey area, or store the complete client contract, the External or Extended header may be used. The General Header blocks #4–8 are basically defined to simplify data management and information identification.
16. The size of all recorder-defined headers (Extended, External and General Trailer) has been increased. The maximum size of an External/Extended header is now 512 MB and a General Trailer may contain up to 128 GB.
17. The maximum Trace Header size has been increased to 8180 bytes to allow multiple positions or other measurements to be inserted in each trace. The space may also be used by the recorder to store an increased amount of recorder-defined blocks.
18. The source information is far more comprehensive than in Rev 2.x. A different General Header block type exists to describe each source type (Vibrator, Airgun, etc.), replacing the General Header Block N of Rev 2.x. The information contained in the source description blocks basically aligns the information in SEG-D with SPS.
19. An additional source information block has been defined to allow specification of the actual firing time of the source (with microsecond accuracy), and the status of the source.
20. Compound sources can be created, i.e. sources containing other sources, allowing SEG-D to store information about, e.g., single airguns and the combined source or single vibrator trucks and the combined vibrator group.
21. Auxiliary trace reference blocks may be attached to the source information, listing which auxiliary traces contain relevant information for the specified source.
22. The source information may be inserted into the General Header or Trace Header depending on what is most useful. For records with multiple source events (like slip-sweep acquisition), storing the source information in the source related auxiliary traces (e.g. source reference signal), is recommended.
23. Allow recording data in 64 bit IEEE

Additional Valid Format Code for bytes 3 & 4 of the General Header #1 is:

8080 64 bit IEEE float demultiplexed

24. To support acquisition systems where sensors are deployed for longer periods of time without external clock synchronization, a special Time drift header block have been added. This allows storing information about drifting clocks (for quality control and more advanced clock corrections post acquisition). It must be noted that even though SEG-D supports logging of the information, SEG-D does not support storing data from multiple drifting time reference systems. Traces must be clock drift corrected prior to record creation if data from multiple sensors are stored in one record.
25. Support for Electromagnetic surveys has been added, including Electromagnetic source description and Electromagnetic receiver description.
26. Sensor calibration information may now be added. SEG-D supports an individual scaling factor, as part of the sensor sensitivity value, and a more complex calibration function in frequency or time domain. The function can either be specified as part of the trace header (frequency domain), or as a separate calibration “trace” (time domain).
27. A set of standard measurements may now be added to a special Measurement header block, which may be inserted into a trace header. Multiple measurement blocks may be used in any trace. Supported measurements are depth, temperature, pressure, wind speed, altitude, uphole time, etc. Note: The format of the Measurement block is still not finalized, discussions still ongoing with Energetics regarding the contents.
28. The General Trailer format has been completely changed from that of Rev 2.x. The new General Trailer format consists of a number of blocks of data, each a multiple of 32 bytes, and starting with a 32 byte description header. Any binary or ASCII block data may be stored unmodified as part of the General Trailer, as long as the block is padded with zeros (0x00 – for binary data) or spaces (0x20 – for ASCII data) until it is a multiple of 32 bytes long.
29. An edit format has been defined as part of the General Trailer, to simplify addition of post acquisition edit records (e.g. by quality control or processing systems), to standardize transfer of edit information between acquisition and processing. The format is based on the *SEG ADS Trace Edit format* (Norris et. al. 1999).
30. Storing positioning files like P1 and P2 as part of the General Trailer (for backup purposes), has been standardized.
31. Some other simple Trailer blocks, like Observer Log and Text Comments have also been defined.
32. Several examples have been added to Appendix E.
33. Revision 2.x Appendix D “Header Descriptors” has been removed.
34. Appendix F, which previously listed specific tape drives and corresponding maximum block sizes, has been removed. SEG-D revision 3.0 supports data on any fixed block, variable block and byte stream device including tapes, disks, DVDs, and network connections with record sizes up to any specific device, operating system, file system, or network limits. The plan is to keep information regarding specific devices, their block sizes and recommended usage in the Technical Standards pages on <http://www.seg.org>. This will allow keeping the information up to date without modifying the standards document.

2.1 Changes Introduced in Revision 2.1

The following list discusses each of the specific changes made in Revision 2.1 compared to Revision 2.0.

1. Revision number changed from 2.0 to 2.1, see
 - Chapter 4, field number 2
 - Chapter 8.2 (General Header # 2, byte 11 and 12).
2. Since Rev 2.1 is intended to handle ultra high density tapes, acceptable media is expanded to include:
STK 9940B, IBM 3592 (Jaguar-1) and IBM TS1120 (Jaguar-2).

For further details, see Appendix F.

3. More than one production line per tape is allowed, as long as a unique combination of **field file number** and a new line **sequence number** are used per storage unit.
The sequence number was added to General Header # 2, byte 21–22. Range is 1–65535 (Set to 0 if not valid).
4. Appendix A is updated (Manufacturers of Seismic Field Recorders).
5. Appendix C is updated (API Producer Organization Codes). Organization codes are now assigned by POSC which maintains the current list of codes (API in previous revision).
6. Producer organization code is no longer a required field.

2.2 Changes Introduced in Rev 2.0

The following list discusses each of the specific changes made in Revision 2.0 compared to Revision 1.0. Also mentioned are changes which were discussed as potential changes to be included in Rev 2.0, but were not included in Rev 2.0.

1. Since Rev 2.0 is intended to handle higher density tapes, acceptable media is expanded to include: 3490/3490E, 3590, D2, and D3.
2. It is not anticipated that the higher density drives will be used to record multiplexed data. Rev 2.0 does not support multiplexed data.
3. No specific changes will be made to SEG-D to handle “non-shot domain” data. Either a new committee should be formed, or the charter of this committee should be extended to develop a new format for this application. It does not appear practical to extend SEG-D to fit this application.
4. No special arrangements will be made to provide a standard method of recording SPS in the SEG-D header. The relevant portions of SPS can be put into existing header extensions in user defined positions.
5. The MP factor description will be modified to clarify the meaning for fixed bit data (see MP discussion in section 7).
6. The description of byte 12 in the General Header is being clarified to clearly state that the byte defines the number of additional blocks. Figure 4 in the SEG-D Rev 1 document will be changed from # BLKS IN GEN HDR to “# Additional blks in Gen Hdr”. Another correction will be made to correctly state, for byte 1 of the General Header, “File number of four digits (0–9999) set to FFFF (Hex) when the file number is greater than 9999.
7. The RECEIVER LINE NUMBER (bytes 1–3) and RECEIVER POINT NUMBER (Bytes 4–6) in the Trace Header Extension have been modified to include a fractional component. An all one’s pattern (FFFFFF₁₆) in either of these fields, will serve as a flag to indicate that the complete five byte value will be located in newly defined locations in the Trace Header Extension. See Trace Header Extension table below.
8. The maximum number of Trace Header Extensions is now limited to 15.
9. Channels within the same Channel Set must now have the same number of Trace Header Extensions. Since all traces within a Channel Set will now contain the same number of Trace Header Extensions, the number of Trace Header Extensions will be indicated in the Channel Set Descriptor. The previously unused nibble of Byte 29 in the Channel Set Descriptor will now be defined to be a 4 bit binary parameter that defines the number of Trace Header Extensions for that Channel Set. Byte 29 of the Channel Set descriptor will now be:

| | | | | | | | |
|------------------|------------------|------------------|------------------|------------------|------------------|------------------|------------------|
| 0 | 1 | 2 | 3 | 4 | 5 | 6 | 7 |
| EFH ₃ | EFH ₂ | EFH ₁ | EFH ₀ | THE ₃ | THE ₂ | THE ₁ | THE ₀ |

As a result of this limitation the Trace Header Extension field in Byte 10 of the Trace Header will also be redefined as a 4 bit value limited to a maximum of 15 Trace Header Extensions.

10. The length of each trace within a Channel Set is now restricted to be the same value. This limitation and the restricting the number of Trace Header Extensions to the same number within a Channel Set will result in each trace within a Channel Set being recorded with the same number of bytes.
11. A tape label will be required on each tape. The details of this label format are described in section 4.

12. Data may be recorded in large logical blocks to maximize the transfer rates with high density tape systems. 3 types of device structures are supported:

A) Variable block length devices.

Every shot record must be aligned on a block boundary (i.e. each block will contain data from only one shot record). Multiple channel sets may be included in each block. When the data to be recorded in a block contains less than the maximum number of bytes in the block, there will be no padding characters to fill the block.

Storage Unit Structure in field 3 in Storage Unit Label must contain the text “RECORD”

B) Byte stream devices

There is no concept of a block, even though there is a hidden underlying physical block structure. Within each file, one or more shot records are written consecutively without any gap.

Storage Unit Structure in field 3 in Storage Unit Label must contain the text “RECORD”

C) Fixed block length devices

Every shot record must be aligned on a block boundary (i.e. each block will contain data from only one shot record). Multiple channel sets may be included in each block. Typically the last block in a shot record will contain less data than the block size, the remaining part of this block will be padded with characters without any information.

Storage Unit Structure in field 3 in Storage Unit Label must contain the text “FIXREC” and the block size is found in field 5 in Storage Unit Label.

Note: Structure A can be mapped to a file directly but one can not re-generate the same interblock gaps and File Marks from data stored on a file. Structure B and C can be mapped to a file directly and the structure can be re-generated apart from the original position of the File Marks.

13. An appendix will be added to indicate the maximum allowable block size for accepted types of media. It is expected that this table will need to be updated approximately once per year.
14. Byte 12 of the Trace Header will have an additional option, TR= 03 Trace has been edited. This parameter will indicate the acquisition system has modified one or more samples of this trace. During data acquisition, if a telemetry error occurs, a sample may be corrupted. Some radio acquisition systems fill in this missing data with a copy of the previous sample, or interpolate to fill in the missing sample. Trace edit can also occur when a noise edit process is applied by the acquisition system. The TR=03 flag should be set for those traces which have been modified by the acquisition system.
15. The SEG-D, Rev 2.0 format treats data going to tape as a byte stream. File Marks are not required to separate shot records, however File Marks may be included in between shot records where appropriate to ease error recovery and/or to provide logical partitioning of the data. If used, File Marks may only be recorded at shot record boundaries. For field tapes, File Marks should be written as frequently as possible, preferably for every shot. If data is staged on disk, many shots can be stored in each file. When SEG-D, Rev 2.0 data is recorded on tape, an EOD mark must be recorded after the last valid record and prior to the end of tape
16. The time standard referenced by byte 14 of the General Header has been changed from GMT to UTC.
17. Partitioning of a tape or other type media volume is now allowed. Each partition, or each tape if not partitioned, constitutes one storage unit. The storage unit label shall consist of the first 128 bytes of the first user-writable tape record in the first user-writable physical block and may, optionally, be followed by a File Mark. No File Mark shall be written before the storage unit label.

18. Added a field in the Trace Header extension to indicate the type of sensor used for that trace (Byte 21).

2.3 Changes Introduced in Rev 1

In 1994, several changes were introduced to SEG-D to increase flexibility. These changes are listed below.

1. To allow for additional defined fields in SEG-D headers, additional blocks are allowed for the General Header and Demux Trace Header.
2. Added provision for an optional set of General Trailer blocks. This type header allows provisions for recording auxiliary seismic system and real-time navigation related data in the trailer. The trailer is optional and typically follows all other recorded data.

The addition of the trailer will allow the accumulation of system faults, data QC information, real-time navigation position, and timing information on the same tape, and contiguous with, the shotpoint that it relates to. By recording this data after all of the other data, additional time is provided for collecting the data and transferring it to the recording system.

The Trailer blocks take the same general form as the Channel Set Descriptor. Byte 11 uses the "Channel Type Identification" set to 1100 to indicate a Trailer block. Bytes 1 and 2 indicate the number of the General Trailer block, with the first block numbered as 1.

All other information in the trailer is optional and may be formatted as desired by the manufacturer/user.

The number of General Trailer blocks is indicated in bytes 13 and 14 of General Header Block #2.

3. Provide provision to include the revision of SEG-D format. Added to Bytes 11 and 12 of General Header Block #2 contain the SEG-D Revision Number. The revision number is a 16 bit unsigned binary number. The Revision number is 1 for the proposed version.

In addition, in the General Header Block #1, nibble 1 of byte 12 contains the number of additional blocks in the general header. Nibble 1, byte 12 is an unsigned binary number. This number will be 1 or greater for SEG D Rev 1.

4. Added provision to include the source and receiver locations for each source and receiver location. Source locations are included in the General Header Blocks. Block #3 contains the position for Source Set #1. Additional General Header Blocks may be included to allow for additional Source Sets.

Source positions are defined by a Source Line Number (three bytes integer and two bytes fraction), a Source Point Number (three bytes integer and two bytes fraction), and a Source Point Index (one byte). This index allows several locations for the source in the grid, the original value is 1 and that value is incremented by 1 every time the source is moved, even when it is moved back to a previous location).

Receiver locations are included in Trace Header Extensions to be used with Demux Trace Headers. Receiver positions are defined by a Receiver Line Number (three integer bytes and two fraction bytes), a Receiver Point Number (three bytes integer and two bytes fraction), and a Receiver Point Index (one byte). This index allows for defining the receiver group in the grid, the original value is 1 and that value is incremented by 1 every time the receiver is moved, even when it is moved back to the previous location.

5. Provide for the use of File Numbers greater than 9999. Bytes 1, 2, and 3 in General Header Block #2 allow for a three byte, binary file number. When the file number is greater than 9999, bytes 1 and 2 in the General Header Block #1 must be set to FFFF.

6. Provide for Extended Channel Sets/Scan Types. General Header Block #2 allows for a two byte, binary number of Channel Sets/Scan Types in bytes 4 and 5. When using the Extended Channel Sets/Scan Types, byte 29 of General Header #1 must be set to FF.
7. Provide for additional Extended and External Header blocks. General Header Block #2 bytes 6 and 7 (for Extended Header blocks) and Bytes 8 and 9 (for External Header blocks) allow the use of a two byte, binary number to allow more than 99 blocks. When using these capabilities, General Header Block #1 byte 31 (for extended) and byte 32 (for external) must be set to FF.
8. Provide a mechanism for recording additional information about vibrator sources. Byte 15 of the General Header Block #N indicates the signal used to control vibrator phase. Byte 16 indicates the type of vibrator (P, Shear, Marine). Bytes 28 and 29 contain the phase angle between the pilot and the phase feedback signal.

The additional vibrator information may be recorded for multiple sets of sources by using additional General Header blocks.

9. Provide for larger number of samples per trace. Using bytes 8, 9, and 10 of the Trace Header Extension.
10. Provide provisions for using 1/2" square tape cartridges. (ANSI X3.180 1989).
11. Allow recording data in IEEE and other new formats.

Additional Valid Format Codes for bytes 3 & 4 of the General Header are:

| | |
|------|---------------------------------------------|
| 0036 | 24 bit 2's compliment integer multiplexed |
| 0038 | 32 bit 2's compliment integer multiplexed |
| 0058 | 32 bit IEEE multiplexed |
| 8036 | 24 bit 2's compliment integer demultiplexed |
| 8038 | 32 bit 2's compliment integer demultiplexed |
| 8058 | 32 bit IEEE demultiplexed |

The IEEE format is fully documented in the IEEE standard, "ANSI/IEEE Std 754 - 1985", available from the IEEE.

The IEEE format is summarized as follows:

| Bit | 0 | 1 | 2 | 3 | 4 | 5 | 6 | 7 |
|--------|------------------|------------------|------------------|------------------|------------------|------------------|------------------|-------------------------------|
| Byte 1 | S | C ₇ | C ₆ | C ₅ | C ₄ | C ₃ | C ₂ | C ₁ |
| Byte 2 | C ₀ | Q ₋₁ | Q ₋₂ | Q ₋₃ | Q ₋₄ | Q ₋₅ | Q ₋₆ | Q ₋₇ |
| Byte 3 | Q ₋₈ | Q ₋₉ | Q ₋₁₀ | Q ₋₁₁ | Q ₋₁₂ | Q ₋₁₃ | Q ₋₁₄ | Q ₋₁₅ |
| Byte 4 | Q ₋₁₆ | Q ₋₁₇ | Q ₋₁₈ | Q ₋₁₉ | Q ₋₂₀ | Q ₋₂₁ | Q ₋₂₂ | Q ₋₂₃ (see Note 1) |

The value (v) of a floating-point number represented in this format is determined as follows:

| | |
|----------------------------------------------------------------------|---------------------------|
| if $e = 255$ & $f \neq 0$. $v = \text{NaN}$ | Not-a-Number (see Note 2) |
| if $e = 255$ & $f = 0$. $v = (-1)^s \times \infty$ | Overflow |
| if $0 < e < 255$. $v = (-1)^s \times 2^{e-127} \times (1.f)$ | Normalized |
| if $e = 0$ & $f \neq 0$. $v = (-1)^s \times 2^{e-126} \times (0.f)$ | Denormalized |
| if $e = 0$ & $f = 0$. $v = (-1)^s \times 0$ | \pm zero |

where e = binary value of all C's (exponent)
 f = binary value of all Q's (fraction)

NOTES: 1. Bit 7 of byte 4 must be zero to guarantee uniqueness of the start of scan in the Multiplexed format (0058). It may be non zero in the demultiplexed format (8058).

2. A Not-a-Number (NaN) is interpreted as an invalid number. All other numbers are valid and interpreted as described above.
12. Allow for the use of blocked records. Allow blocked demultiplexed data (integral number of traces in a block). Headers will not be blocked. All records in a block will be the same size. Not all blocks will be the same size. Byte 20 in the general header (B1 = 1) will indicate blocked data. Blocks will be limited to 128 kilobytes. All traces in a block are in the same Channel Set.
13. Added the effective stack order (unsigned binary), in byte 30 in the Channel Set descriptor. Set to 0 if the trace data was intentionally set to real 0. Set to 1 if no stack. Set to the effective stack order if the data is the result of stacked data (with or without processing).
14. Improved definition of undefined fields. All undefined fields will be specified as: "This field is undefined by this format".
15. Added provisions for a Trace Edit byte (byte 10 of Demux Trace Header) to indicate traces zeroed for roll-on or roll-off and to indicate deliberately zeroed traces.
- TR=0 No edit of this trace
TR=1 Trace part of dead channels for roll-on or roll-off spread; trace intentionally zeroed.
TR=2 Trace intentionally zeroed.
16. Increased precision of MP factor, using byte 7 of the Channel Set descriptor.
17. Since modern seismic vessels record more than one streamer at a time, a standard convention is required to identify which streamer recorded each channel of data. The Channel Set Descriptors are updated to handle this task. The definition of a channel set is expanded to include the following rules. A channel set is a group of channels that:
- a) Use identical recording parameters. This includes the same record length and sampling interval.
 - b) Use identical processing parameters, including the same filter selection and array forming parameters. A field has been added to Channel Set Descriptor byte 32 to describe any array forming applied to data in that channel set.
 - c) Originates from the same streamer cable for marine data. The streamer cable number for each channel set has been added to Channel Set Descriptor byte 31.
 - d) Consists of channels with the same group spacing. For example, if one steamer has short group spacing close to the boat and longer groups spacing at long offsets, the data from that steamer would be recorded as two channel sets.

In addition, the first channel in each channel set will start with Trace number one.

18. Correct the MP factor calculation (refer to Appendix E7 in the SEG-D recording format description.)

MP CALCULATION

The calculation of **MP** for a data recording method is given by one of the following equations:

- (1) $MP = FS - PA - C_{max}$; for binary exponents,
- (2) $MP = FS - PA - 2 \times C_{max}$; for quaternary exponents,
- (3) $MP = FS - PA - 4 \times C_{max}$; for hexadecimal exponents (except the 4 byte excess 64 method),
- (4) $MP = FS - PA - 4 \times (C_{max} - 64)$; for excess 64 hexadecimal exponents,
- (5) $MP = FS - PA - (C_{max} - 127)$; for 32 bit IEEE exponents,

where

2^{FS} = Converter full scale (millivolts),

2^{PA} = Minimum system gain,

and

Cmax = maximum value of the data exponent,

Cmax = 15 for binary exponents,

7 for quaternary exponents,

3 for hexadecimal exponents except excess 64,

127 for excess 64 exponents, and

255 for 32 bit IEEE exponents.

19. Added the option for using record lengths in millisecond increments (rather than the previous 0.5 second increments). The Extended Record Length is the record length, in unsigned binary milliseconds, and is recorded in bytes 15–17 in General Header Block #2. If this option is used, Record Length (R), in the General Header Block #1, bytes 26, 27 must be set to FFF.

B) Byte stream devices

There is no concept of a block, even though there is a hidden underlying physical block structure. Within each file, one or more shot records are written consecutively without any gap.

Storage Unit Structure in field 3 in Storage Unit Label must contain the text “RECORD”, and Maximum Block Size should be set to 1.

C) Fixed block length devices

Every shot record must be aligned on a block boundary (i.e. each block will contain data from only one shot record). Multiple channel sets may be included in each block. Typically the last block in a shot record will contain less data than the block size, the remaining part of this block will be padded with characters without any information.

Storage Unit Structure in Field 3 in Storage Unit Label must contain the text “FIXREC” and the block size is found in Field 5 in Storage Unit Label.

Note: Structure A can be mapped to a file directly but one can not re-generate the same inter-block gaps (if present) and File Marks from data stored on a file. Structure B and C can be mapped to a file directly and the structure can be re-generated apart from the original position of the File Marks.

The SEG-D, Rev 3.0 format treats data going to tape as a byte stream. File Marks are not required to separate shot records, however File Marks may be included between shot records where appropriate to ease error recovery and/or to provide logical partitioning of the data. If used, File Marks may only be recorded at shot record boundaries. For field tapes, File Marks should be written as frequently as possible, preferably for every shot. If data are staged on disk, many shots can be stored in each file. When SEG-D, Rev 3.0 data are recorded on tape, an EOD mark must be recorded after that last valid record and prior to the end of tape.

If the tape media supports multiple partitions, SEG-D data may be written to any of the partitions of the tape, each beginning with a Storage Unit Label. Data from one partition cannot “run-over” into a subsequent partition, each partition must be capable of being decoded in isolation.

On one tape, it is allowable to mix partitions containing SEG-D data with partitions containing non SEG-D formatted information.

The headers of SEG-D Rev 3.0 can be very large compared to previous versions of the format. The maximum for each of the main header types are shown below:

- General Header: 2,097,120 bytes ~ 2 MB
- Skew headers: 2,097,120 bytes ~ 2 MB
- Scan type header/Channel Set descriptors: 6,291,360 bytes ~ 6 MB per scan type (up to 99 scan types)
- Extended Header: 536,870,880 bytes ~ 512 MB
- External Header: 536,870,880 bytes ~ 512 MB
- General Trailer: 137,438,953,440 bytes ~ 128 GB
- Trace Header: 8,180 bytes ~ 8 kB

In addition, the maximum trace size is

- Trace: 8,180 (header) + 34,359,738,360 (data) bytes ~ 32 GB

Note: The headers and traces may therefore span multiple tape blocks.

SEGD Rev 3.0 disconnects tape blocks from data blocks completely, the start of a header block/start of trace may be anywhere in a tape block. A header may also be split between two tape blocks, e.g. a trace header may have just one byte in one tape block, and the rest continuing in the next block.

The maximum block size used on the storage media is listed in the Tape Label, bytes 20-29. The maximum block size is limited to about 4 GB in SEG-D Rev 3.0. If the storage device supports less than 4GB blocks, the maximum block size is determined by the manufacturer of the device. The following values should be used as the maximum block size in the media Tape Label:

- For fixed block size media, this will be the block size of the media.
- For variable block media, this will be the maximum block size used on the tape. The size is determined by the data recorder, and may be less than the maximum value determined by the device manufacturer. The size should be selected to allow efficient reading and writing data to/from the media.
- For byte stream media, e.g. tape devices like D2, disk, USB memory sticks, network transfer, etc., the maximum block size is always set to 1.

SEG-D data is streamed to/from the storage device as a stream of bytes, split into blocks as defined by the device manufacturer and the maximum block size in the Tape Label, with the following modifications:

- The Tape Label must be located at the beginning of the media, with no preceding data.
- It is strongly recommended to write an end-of-file mark after the Tape Label.
- The General Header Block #1 (start of record), the first Trace Header (start of data) and the first General Trailer block (start of trailer) will always be located at the beginning of a device block. For fixed block size media, this means the previous block may have to be padded with zeros, and for variable block size media, the previous block may be smaller than the maximum block size indicated in the Tape Label.

Information layout

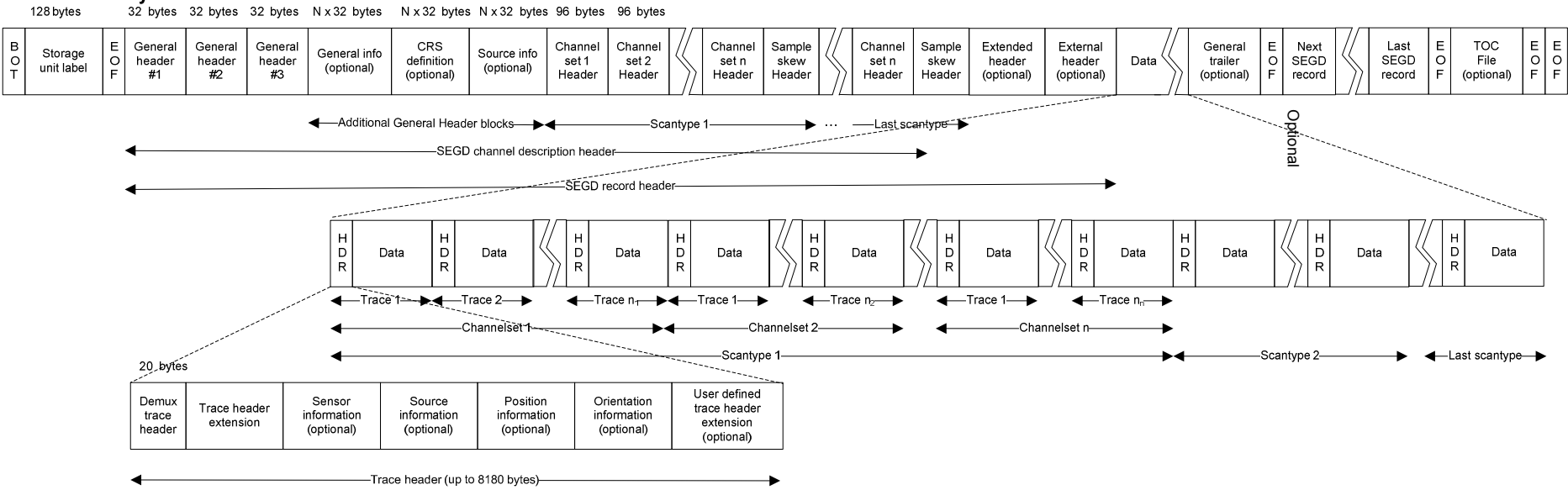

Figure 1. Record Format

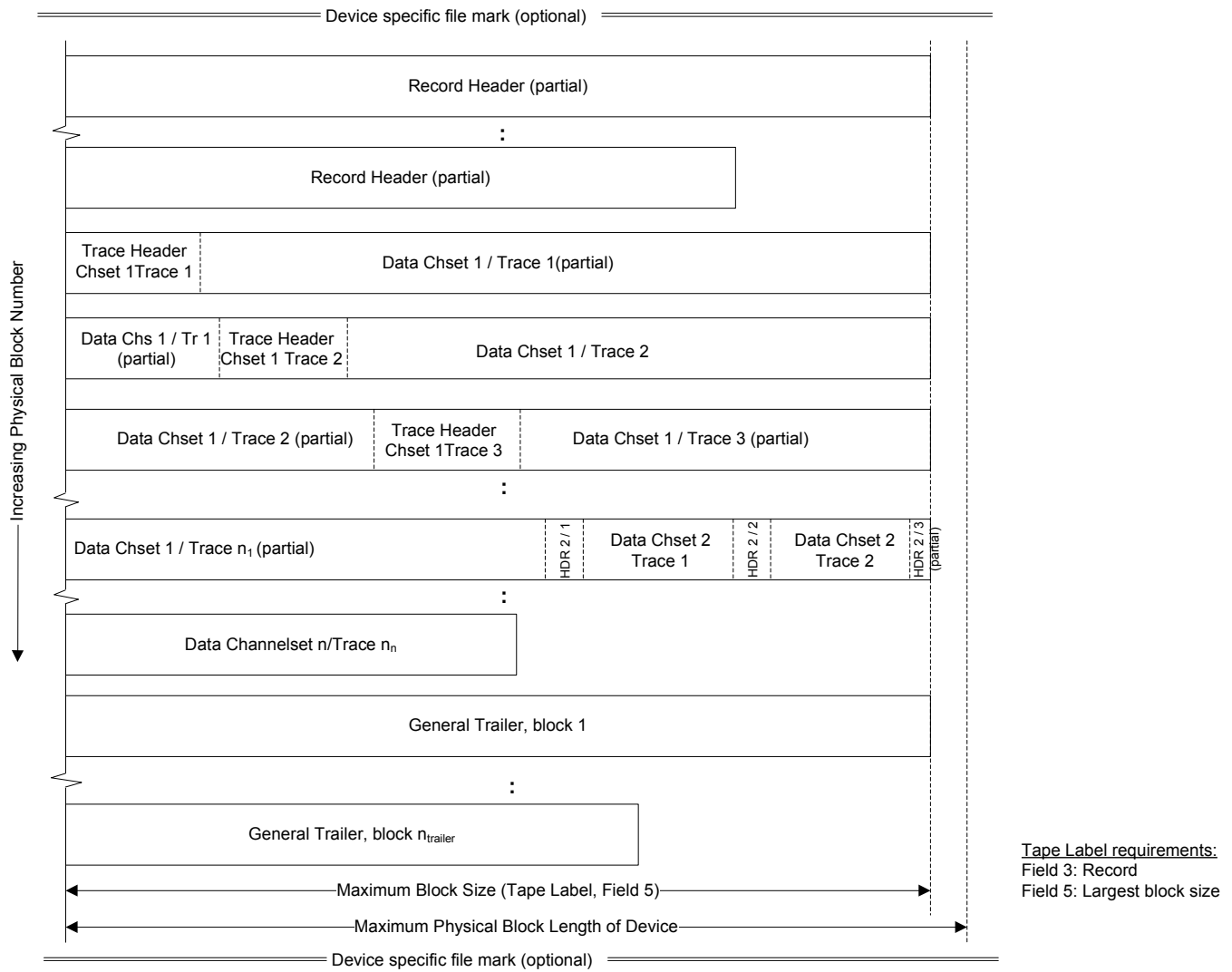

Figure 2. Variable Block Length Format Example

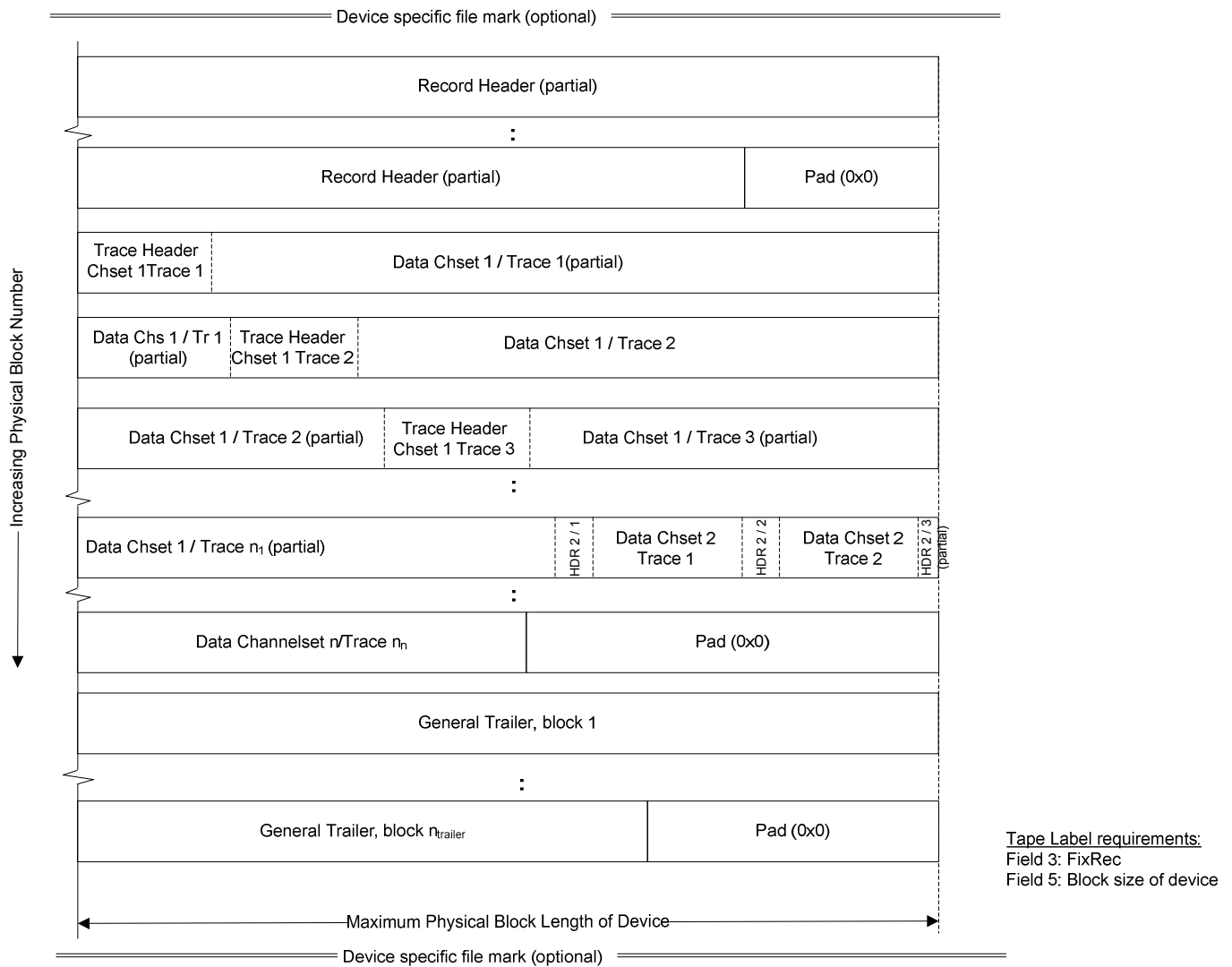

Figure 3. Fixed Block Length Format Example

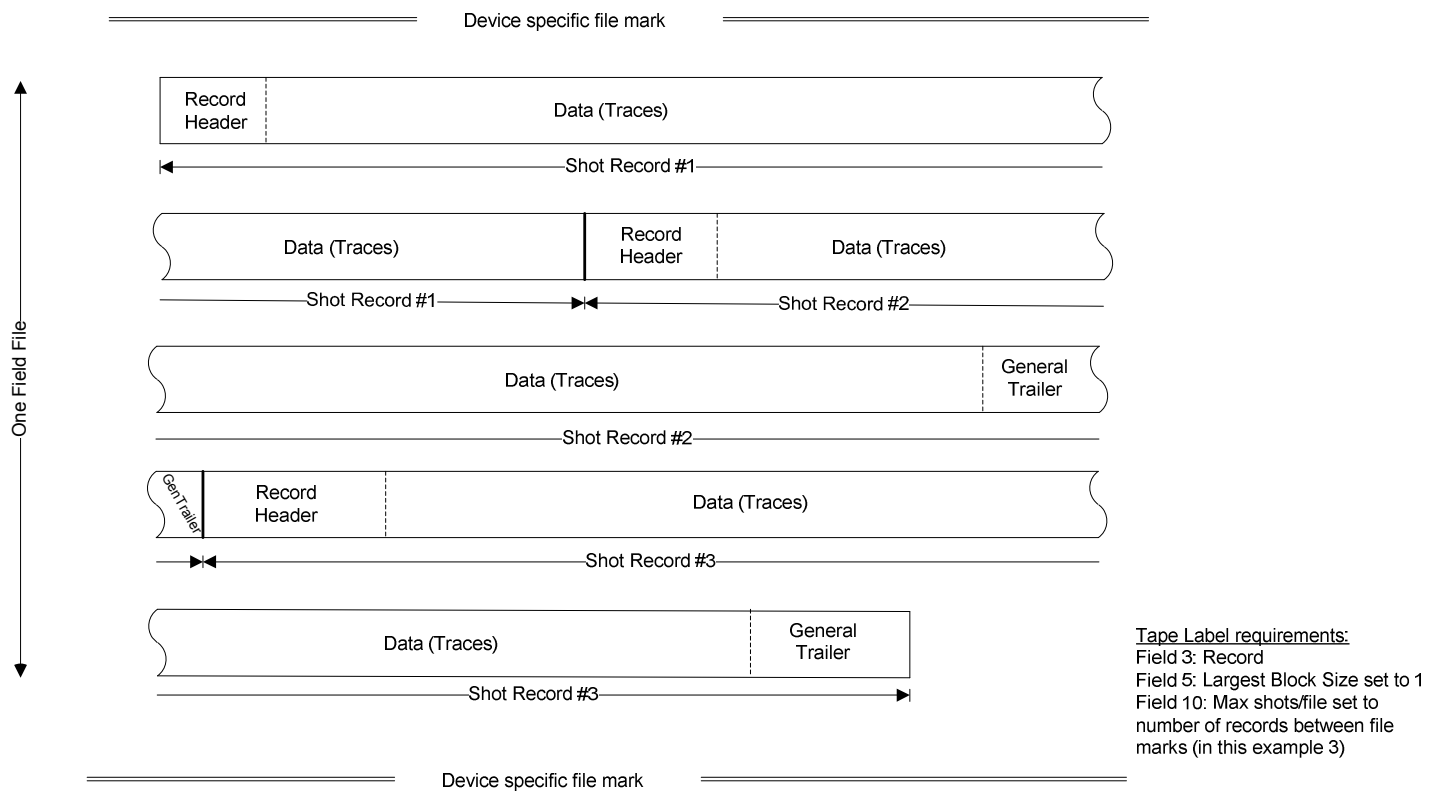
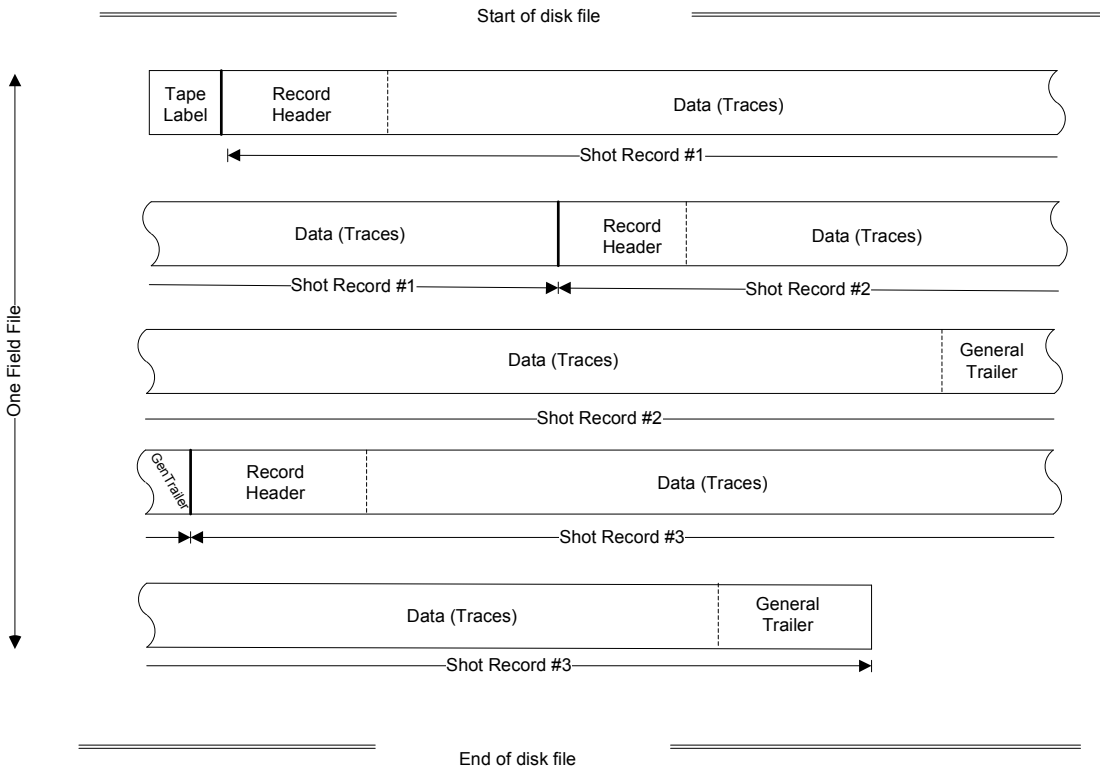

Figure 4. Byte Stream Device Example (3 records with and without General Trailer)



Disk file
 Format is similar to Byte Stream device, however each disk file is a storage unit starting with a Tape Label, and may contain any number of SEG-D records.

Network transfer (e.g. Ethernet)
 Similar format is used when transferring SEG-D records across networks. Every time a network port is opened/transfer initiated, it is viewed as starting a new storage unit, hence a Tape Label must be sent prior to any SEG-D records. If number of records to be sent is unknown at the initiation of transfer, Field 10 of the Tape Label is set to 0.

Tape Label requirements:
 Field 3: Record
 Field 5: Largest Block Size set to 1
 Field 10: Max shots/file set to number of records in file (in this example 3). If unknown at the time of Tape Label creation, set to 0 (undefined/unknown)

Figure 5. Disk File Example (3 records with and without General Trailer)

3.1 SEG-D timestamp

SEG-D Rev 3.0 supports a more accurate time stamp than provided by the earlier versions. (Rev. 2.x had only a timestamp accurate to one second stored in General Header Block #1.) There is need to be able to give each sample an accurate timestamp, to be able to tie seismic data to external events, externally acquired data, or similar. Previously every manufacturer had their own proprietary time format, e.g. by storing a timestamp as part of the Extended or External Header. As of SEG-D Rev 3.0, a timestamp is stored in General Header Block #3, bytes 1 to 8. It is still permissible to store timestamps as part of the External or Extended Header, however the official time of the SEG-D record is now found in General Header Block #3.

Definition

A SEG-D Rev 3.0 timestamp is an 8 byte, signed, big-endian integer counting the number of microseconds since 6 Jan 1980 00:00:00 (GPS epoch). The timestamp is equal to GPS time converted to microseconds.

This 8 byte timestamp is heretofore referred to as a *SEG-D timestamp*.

The number range an 8 byte microsecond count supports is approximately 9223372036854 seconds or 292471 years.

Dates before 6 Jan 1980 00:00:00 will have negative timestamps. The earliest timestamp allowed in prior revisions of SEG-D was 1 Jan 1970 00:00:00 (SEG-D epoch). See below for more details regarding conversion between timestamp and UTC.

There are several reasons why GPS time has been selected as basis of SEG-D timestamp:

- Most seismic acquisition systems use GPS for positioning, and hence have GPS time easily available
- GPS time does not contain leap seconds, which would cause a problem for processing of any record crossing leap second boundaries (remember, in Rev 3.0 measurements at several different times during the record may exist). For this reason, UTC was not chosen as basis for timestamp.
- There are other time formats without leap seconds, such as International Atomic Time (TAI) which tracks proper time on the Earth's geoid; however GPS is more commonly used in seismic acquisition systems.
- There are proposals for redefinition of UTC (to eliminate leap seconds). This would cause problems for handling historical data (i.e. tapes), as there would be a difference in definition before and after the change.
- Leap seconds are unpredictable (the Earth rotation speed changes at an unpredictable rate), so it is not possible to create a mathematical formula to calculate leap second.

Relative Time Mode record

For recording systems without absolute time, the timestamp in General Header Block #3 (bytes 1 to 8) must be set to 0, and the Relative Time Mode in General Header Block #3 (byte 30) set to 1. All timestamps in the record must then be relative to start of record (time zero). If reference to absolute time is required for such a record, the manufacturer is responsible for providing the required information separately.

The time stamp in General Header Block #1 can in Relative Time Mode either be set to 1 Jan 1970, an approximate value of the actual time, or a relative time compared to other records in the survey, whatever the manufacturer determines would best help interpretation of the data.

SEG-D timestamp and UTC conversion

There are a few problems with choosing GPS time as foundation for a SEG-D timestamp, mainly related to the timestamp in General Header Block #1, which is UTC (Coordinated Universal Time) or GMT (Greenwich Mean Time). This has not been changed in Rev. 3.0 for backward compatibility. However, when reading and writing SEG-D Rev 3.0 records, it is important to handle the differences, i.e. by adding the proper number of leap seconds.

GPS was aligned with UTC on 6 Jan 1980, but due to the variation in Earth's rotation, the definition of seconds, etc., leap seconds have to be added to UTC. As of April 2009, *UTC time is 15 seconds behind GPS time.*

The sequence of dates of the UTC second markers during leap second are:

| | |
|-------------------|-------------|
| 31 December 2005, | 23h 59m 59s |
| 31 December 2005, | 23h 59m 60s |
| 01 January 2006, | 0h 0m 0s |

Note: *The interpretation of UTC timestamps needs to allow 60 as a value of seconds! This was previously not accounted for in the Rev 2.x standard.*

As GPS time is not defined prior to 6 Jan 1980, leap seconds are added to UTC as defined by International Atomic Time (TAI) such that the SEG-D timestamp equals TAI time plus 19 seconds at the TAI epoch (1 Jan 1972 00:00:00). (The reason for the 19 seconds difference is the TAI choice to start off with an initial difference to UTC of 10 seconds (TAI was synchronized with UTC at the start of 1958, and has drifted ever since), then 9 leap seconds were added during the 1970s. As GPS time was synchronized to UTC 6 Jan 1980, GPS time is now running at a fixed 19 second difference to TAI.)

Prior to 1970 no official leap seconds existed, so SEG-D defines for the purpose of timestamp/UTC conversions that no leap seconds exist for 1970 and 1971 (this should have very few practical consequences).

UTC to SEG-D timestamp difference:

01 MAR 2008: UTC 14 seconds behind timestamp

06 JAN 1980: UTC equal to timestamp

01 JAN 1970: UTC 9 seconds ahead of timestamp

See Appendix E for examples of conversions between UTC and SEG-D timestamp.

The table below shows leap seconds added to UTC time since 1970. Note the values for 1970 and 1971 (in italics) are not according to international standards; they are just values used to allow conversion of dates back to 1 Jan 1970 (SEG-D epoch):

| Year | 30 June | 31 Dec |
|----------------------|----------------|------------------------|
| <i>1970</i> | <i>none</i> | <i>none</i> |
| <i>1971</i> | <i>none</i> | <i>none</i> |
| 1972 | +1 second | +1 second |
| 1973 thru 1979 | none | +1 second each year |
| 1980 | none | none |

| | | |
|----------------------|-----------|-----------|
| 1981 | +1 second | none |
| 1982 | +1 second | none |
| 1983 | +1 second | none |
| 1984 | none | none |
| 1985 | +1 second | none |
| 1986 | none | none |
| 1987 | none | +1 second |
| 1988 | none | none |
| 1989 | none | +1 second |
| 1990 | none | +1 second |
| 1991 | none | none |
| 1992 | +1 second | none |
| 1993 | +1 second | none |
| 1994 | +1 second | none |
| 1995 | none | +1 second |
| 1996 | none | none |
| 1997 | +1 second | none |
| 1998 | none | +1 second |
| 1999 thru 2004 | none | none |
| 2005 | none | +1 second |
| 2006 | none | none |
| 2007 | none | none |
| 2008 | none | +1 second |
| 2009 | none | none |
| 2010 | none | none |

3.2 Multi-component data

Rev 2.x had limited support for multi-component data, but with several deficiencies. Rev 3.0 introduces several new sensor types, and Position/Orientation header blocks to better cope with multi-component acquisition.

Multi-component data should be recorded with each component in separate channel sets, i.e. the X component in one channel set, the Y component in another, etc. The component type must be clearly indicated in the Channel Set Header and Trace Header Extension #1. The indices in Trace Header Extension #1 (i.e. receiver line/point/point index/group index/depth index/reshoot index) will indicate which traces have to be processed together as a unit, e.g. for rotation. The group index will indicate the component number. The sensor type will indicate which type of data each trace contains. Component numbering must be made such that

$$\begin{bmatrix} C_{north} \\ C_{east} \\ C_{vertical} \end{bmatrix} = \begin{bmatrix} R_{11} & R_{12} & R_{13} \\ R_{21} & R_{22} & R_{23} \\ R_{31} & R_{32} & R_{33} \end{bmatrix} * \begin{bmatrix} C_1 \\ C_2 \\ C_3 \end{bmatrix}$$

C is a component as indicated, R is the rotation matrix described by the values found in the Orientation Header. C₁, C₂, C₃ indicates the component numbers (group index) that must be used in the trace extension header. C_{north}, C_{east}, C_{vertical} are components in the indicated direction after rotation. Please refer to the drawing in the Orientation Header section for a better description of the different components.

3.3 Extended recording mode

To be able to support different types of advanced recording systems requiring very long record times, SEG-D supports an *Extended Recording Mode*.

Extended Recording Mode is turned on by setting the Extended Recording Mode flag of General Header Block #3 to 1 (byte 29). The trace will then start at the time indicated by the Timestamp Block in the Trace Header, not as calculated by using the Start Time (byte 5–8) of the Channel Set Header. As a consequence of this, the trace in Extended Recording mode can utilize the entire 4,294,967,295 samples trace length.

As a Timestamp block is used to determine the time of first sample in each Channel Set (e.g. each data block), Extended Recording mode also allows recording non-continuous data. By adjusting the number of samples in the Channel Set header (bytes 13-16), and the start time in the Timestamp header (bytes 1-8), the data may contain holes. Note that the number of samples in each channelset is not required to be the same. Please refer to Appendix E.11 (and E.10) for some examples of how Extended Recording Mode may be utilized.

3.4 Permanent recording systems

SEG-D Rev 3.0 is also designed to support permanent system recording, though its primary usage is online acquisition of land/marine/seabed/transition zone surveys.

A permanent system consists of units with typically a few sensors, and recording can last for days or even weeks. SEG-D 3.0 supports traces of up to 2147 seconds in length. To record data for longer than this, multiple channel sets must be used, i.e. the same traces continue into the next channel set. See *Extended Recording Mode* above. Multiple traces from the same sensor are not allowed in one channel set, but it is not necessary to make a new scan type for the next channel set. This allows recording of up to 4,294,967,295 samples per trace * 65535 (max number of channel sets) = 281,470,681 seconds or approximately 3257 days with highest sample rate (1 microsecond). For a more commonly used sample rate of 2 milliseconds, the maximum record length is increased to more than 17850 years. If longer recording is required, multiple SEG-D records must be created. (Note: The example above assumes only one channel

type is recorded. If multiple channel types are needed, multiple channel sets must be created, and the maximum record length will be reduced accordingly.)

The sizes of headers have been extended to support the extended amount of meta information required for permanent surveys. Metadata recording incidents occurring throughout the record may appear as part of the External or Extended Headers, inserted into the Trace Header Extension, or appended to the General Trailer. For devices with limited amount of memory and CPU, the General Trailer option might be preferable. All metadata should be tagged with the SEG-D timestamp (if time related), and/or scantype#/channel set#/trace# (if trace related, and information not recorded as part of the Trace Header).

3.5 Time drift

Some acquisition systems deploy single sensor unit for long periods of time without synchronization with other parts of the acquisition system or an external clock reference (e.g. GPS). Time drift (i.e. the clock running at a faster or slower rate than GPS) is then a problem. SEG-D supports recording the time drift for each individual trace in the Time Drift Header block by storing the time of deployment and retrieval of the sensor, and the corresponding time offsets.

The data can then be time drift corrected using these values directly (linear time correction). If a more advanced time drift correction is desired, the manufacturer is free to do so. The manufacturer must then provide the time drift correction information in manufacturer specific header blocks or possibly other external data.

Trace data from a sensor unit may be recorded in SEG-D format using a drifting clock, both in normal and extended recording mode. However all channels within the record must have the same time drift (i.e. use the same time reference system).

Note:

Trace data *must* be time drift corrected before merging trace data from multiple drifting sensor units into one single SEG-D record, i.e. start of trace must be aligned, and sample rate must be corrected. SEG-D does not support irregular (drifting) sample intervals or time skew between channels other than specified in the skew blocks and trace sample skew values.

See Appendix E, EM survey, for more details regarding the time drift correction.

3.6 Positions in SEG-D

SEG-D allows for multiple coordinate tuples for any location. A coordinate tuple is an ordered set of coordinates describing a position. For redundancy, two coordinate tuples can be given in different coordinate reference types for any position, e.g. geographic and projected. Coordinate reference system types are:

| <u>CRS type</u> | <u>Coordinate Tuple</u> | | |
|------------------------------------------|----------------------------------------------------|----------------------------------------------------|-------------------------------------------------------------|
| | <u>Coord 1</u> | <u>Coord 2</u> | <u>Coord 3</u> |
| projected <small>(see note 1)</small> | easting or northing <small>(see note 2)</small> | northing or easting <small>(see note 2)</small> | (not used) |
| geographic2D | latitude | longitude | (not used) |
| geographic3D | latitude | longitude | ellipsoidal height |
| vertical | (not used) | (not used) | gravity-related height or depth <small>(see note 3)</small> |
| geocentric | geocentric X | geocentric Y | geocentric Z |
| compound geographic+vertical | latitude | longitude | gravity-related height or depth <small>(see note 3)</small> |

| | | | |
|-----------------------------------------------------------------------------------------------------------------------------------------------------------------------------------------------------------------------------------------------------------------------------------------------------------------------------------------------------------------------------------------------------------------------------------------------------------------------------------------------------------------------------------------------------------------------------------------------------------------------------------|-------------------------------------|-------------------------------------|-------------------------------------------------|
| compound projected+vertical | easting or northing (see note 2) | northing or easting (see note 2) | gravity-related height or depth (see note 3) |
| Notes: 1) Sometimes called "map grid". 2) There is significant variation worldwide in the convention used for projected CRS axis order and abbreviation. In some cases the easting will be given before the northing and in other cases the order will be northing before easting. In both of these scenarios the axes <i>may</i> be labeled X and Y; in such instances the first coordinate will be labeled X regardless of whether easting or northing and the second coordinate labeled Y. 3) Whether vertical coordinates are heights (positive up) or depths (positive down) will be defined in the CRS definition. | | | |

These three fields need to hold the following values:

| | Coord 1 | | Coord 2 | | Coord 3 | |
|----------------------------------------------------------|------------------------|------------|------------------------|------------|-----------------------|------------|
| | min | max | min | max | min | max |
| Value range: | -9,999,999 | 60,800,000 | -9,999,999 | 60,800,000 | -6,400,000 | 6,400,000 |
| Resolution: | 10 significant figures | | 10 significant figures | | 9 significant figures | |
| All coordinate fields are to be capable of being signed. | | | | | | |

Every coordinate tuple must be time-stamped, allowing multiple coordinate tuples to be given for any source or receiver location in the record. Coordinates for each location may be given for various phases of a project – planning, execution, etc.

Coordinates only define location unambiguously when the Coordinate Reference System (CRS) to which they are referenced has been identified. This is done through the Location Data and/or Location Data EPSG Reference extended textual stanza. That Location Data stanza may be supplemented with a Location Data Transformation extended textual stanza. These stanzas are defined in Appendix D and stored in the General Header in multiple Coordinate Reference System Identification blocks.

All coordinates in a SEG-D file should preferably reference the same coordinate reference system. One CRS definition and Location Data stanza then applies to all locations. Should there be a requirement to store coordinates in one of a number of CRSs, then each CRS requires identification through separate Location Data and/or Location Data EPSG Reference extended textual stanzas. Each coordinate set must be related to the relevant CRS through a reference to the relevant Location Data Stanza ID value, a single integer number between 1 and 65535.

4.0 SEG-D, Rev 3.0 Structure

4.1 Rev 3.0 Storage Unit Label (Tape Label)

The first 128 bytes of data on a Rev 3.0 tape must consist of ASCII characters and will constitute a Storage Unit Label. This label is very similar to the RP-66 storage unit label. The Storage Unit Label is also often referred to as the “Tape Label” for historical reasons. The label format is summarized in the table below.

If the tape media supports multiple partitions, SEG-D data may be written to any of the partitions of the tape, each beginning with a Storage Unit Label. Data from one partition can not “run over” into a subsequent partition, each partition must be capable of being decoded in isolation.

On one tape, it is allowed to mix partitions containing SEG-D data with partitions containing non SEG-D formatted information.

Table 1: Label

| Field | Description | Bytes | Start – end byte |
|-------|--------------------------------------------|-------|------------------|
| 1 | Storage unit sequence number | 4 | 1 – 4 |
| 2 | SEG-D Revision | 5 | 5 – 9 |
| 3 | Storage unit structure (fixed or variable) | 6 | 10 – 15 |
| 4 | Binding edition | 4 | 16 – 19 |
| 5 | Maximum block size | 10 | 20 – 29 |
| 6 | API Producer organization code | 10 | 30 – 39 |
| 7 | Creation date | 11 | 40 – 50 |
| 8 | Serial number | 12 | 51 – 62 |
| 9 | Reserved | 6 | 63 – 68 |
| 10 | Storage set identifier | 60 | |
| 11 | External Label Name | 12 | 69 – 80 |
| 12 | Recording Entity Name | 24 | 81 – 104 |
| 13 | User defined | 14 | 105 – 118 |
| 14 | Max shot records per field record | 10 | 119 – 128 |

Field 1 The **Storage Unit Sequence Number** is an integer in the range 1 to 9999 that indicates the order in which the current storage unit occurs in the storage set. The first storage unit of a storage set has sequence number 1, the second 2, and so on. This number is represented using the characters 0 to 9, right justified with leading blanks if needed to fill out the field (No leading zeros). The rightmost character is in byte 4 of the label. *This field is optional.* If not used, it must be blank (filled with blank characters). This implies that this is the only storage unit within the storage set. Separate Storage Sets should be used for different data types.

Field 2 The **SEG-D Revision** field indicates which revision of SEG-D was used to record the data on this tape. SD3.0 indicates that the data was recorded using SEG-D, Revision 3.0 (SD2.1 in previous revision) - *This field is required.*

Field 3 **Storage Unit Structure** is a name indicating the record structure of the storage unit. This name is left justified with trailing blanks if needed to fill out the field. The leftmost character is in byte 10 of the label. For SEG-D, Rev 3 tapes, this field must contain “RECORD” or “FIXREC”. *This field is required.*

“RECORD” — Records may be of variable length, ranging up to the Blocksize length specified in the maximum Block size field of the storage unit label (if not zero). If the maximum Block size specified is zero, then records may be of any length.

“FIXREC” — All records in the storage unit have the same length, namely that specified in the maximum Block size field of the storage unit label. Although all storage units in the same storage set must have a FIXREC structure, the maximum record length may be different in different storage units. When the FIXREC option is used, then the maximum record length field shall not be 0 (zero).

Field 4 **Binding edition** is the character B in byte 16 of the label followed by a positive integer in the range 1 to 999 (no leading zeros), left justified with trailing blanks if needed to fill out the field. The integer value corresponds to the edition of the Part 3 of the API, RP66 standard used to describe the physical binding of the logical format to the storage unit. *This field is required.* The field should be set to ‘B2 ’ for SEG-D Rev 3.0.

Field 5 **Maximum Block Size** is an integer in the range of 0 to 4,294,967,295 ($2^{32}-1$), indicating the maximum block length for the storage unit, or 0 (zero) if undeclared. This number is represented using the characters 0 to 9, right justified, with leading blanks if necessary to fill out the field (no leading zeros). The rightmost character is byte 29 of the label. A valid value or 0 (zero) must be recorded. A value of 1 means byte stream device (e.g. disk). *It is highly recommended to indicate the maximum block length where possible, as this will determine the size buffer needed to read the data, and will enable reading the data at a more optimal speed (using multi-block read).*

Field 6 **Producer organization code** is an integer in the range of 0 to 4,294,967,295 ($2^{32}-1$) indicating the organization code of the storage unit producer. This number is represented using the characters 0 to 9, right justified, with leading blanks if necessary to fill out the field (NO leading zeros). The rightmost character is byte 39 of the label. *This field may be empty, i.e. may contain all blanks, in which case no storage unit producer is specified (i.e. same as RP-66 V2).*

Organization codes are assigned by Energistics, formerly the Petrotechnical Open Standards Consortium (POSC), which maintains the current list of codes. Please refer to Appendix C for a list of the currently assigned codes. To request a new organization code, contact:

Energistics
24 E. Greenway Plaza
Suite 1315
Houston, TX 77046-2414 USA
+1 713 784-1880 telephone
+1 713 784-9219 fax
info@energistics.org

Field 7 **Creation date** is the earliest date that any current information was recorded on the storage unit. The date is represented in the form dd-**MMM**-**yyyy**, where **yyyy** is the year (e.g. 1996), **MMM** is one of (JAN, FEB, MAR, APR, MAY, JUN, JUL, AUG, SEP, OCT, NOV, DEC), and **dd** is the day of the month in the range 1

to 31. Days 1 to 9 may have one leading blank. The separator is a hyphen (code 45₁₀). *This field is required.*

Field 8 **Serial number** is an ID used to distinguish the storage unit from other storage units in an archive of an enterprise. The specification and management of serial numbers is delegated to organizations using this standard. If an external label is used the name/number must be a subset of the serial number or the External Label Name in Field 10, and must occupy the rightmost characters in the serial number (or External Label Name). *This field is required.*

Field 9 This field is reserved and should be recorded as all blanks (code 32₁₀).

Field 10–12 The **Storage set identifier** is a descriptive name for the storage set. Every storage unit in the same storage set shall have the same value for the **user defined portion** of the storage set identifier in its storage unit label. Included in the **Storage Set Identifier** is the **External Label Name**. The characters in this field are right justified with leading blank characters as required. If the tape does not have a physical label, then this field must be blank. A physical label is optional, but if it exists, then this field is required only if the external label is different from the lower 6 characters of the Serial Number in Field 8. The next field in the Storage set identifier is the **Recording Entity Name**. This must contain the crew number or name, or some other unique identifier which will differentiate the recording entity which recorded this data from any other recording entity within the organization (as included in field 6). The 24 bytes may be any alphanumeric characters. If multiple recording systems are used on a vessel or crew, then data recorded on each system must be clearly distinguished. For example, an ABC Geophysical crew (party 13), on the M/V Gopher, recording data on two Zip 6000 recording systems might have a Recording Entity Name on tapes recording on the first recording system of:

ABC, Gopher, P13, Zip#1

On the second system, the Recording Entity Name might be:

ABC, Gopher, P13, Zip#2

The Recording Entity Name field is required.

Field 13 **USER DEFINED**

The next 14 bytes in this field may contain any other user input information. The only restriction is that the data must be in ASCII.

Field 14 **Max Number of shot records per field record.** Field Records are data between File Marks (10 bytes).

It is not acceptable to use an ANSI label (or any other label or data) prior to the Storage Unit Label.

An external, physical label is not required.

4.2 Rev 3.0 Table of Contents (TOC) File (optional)

The SEG-D TOC FILE is a table of contents for a specific tape/file/storage unit. The TOC file consists of a 448 byte header defining general survey information, followed by a list containing one 64 byte entry for each SEG-D record on tape. The purpose of this list is to provide fast location of data, and give an overview of the storage media without scanning through the entire e.g. tape.

The TOC file is optional, however for tapes and other large media it is highly recommended to create a TOC file.

Note: The recorder is responsible for allocating enough space at the end of the storage media to allow storage of the TOC file. The size of the TOC file is not large, please refer to the end of this section for an example of TOC file size calculation.

The SEG-D TOC file may be stored on disk to provide an overview of, and fast access to, the data on the media. It is critical that the Serial Number in the Tape Label, and the SEG-D TOC Header matches to facilitate this functionality. The naming convention of these files should include the Serial Number, Storage Unit Sequence Number etc. from the Tape Label, to ease the matching of TOC file to tape media.

On tape the TOC file must be separated from the other data with a File Mark before and after. The TOC file is most commonly stored at the end of tape (after last SEG-D record, before any double File Mark or end of media), though it may also be stored at the beginning, directly following the Tape Label.

On disk (and similar devices), where no File Marks exists, the TOC file will not be separated from the rest of the data, hence the reader will need to recognize the TOC File Header *TOC identifier* "SEGD TOC FILE" .

The TOC file consists of a header, followed by one TOC entry for each SEG-D record on the storage media.

4.2.1 TOC Header

| Field | Description | Data type | Start – end byte |
|-------|----------------------------------|------------|------------------|
| 1 | TOC identifier. | ASCII text | 1 – 13 |
| 2 | SEG-D Revision | ASCII text | 14 – 19 |
| 3 | Serial number | ASCII text | 20 – 31 |
| 4 | Client Identification | ASCII text | 32 – 63 |
| 5 | Vessel/Crew Identification | ASCII text | 64 – 95 |
| 6 | Country | ASCII text | 96 – 127 |
| 7 | Region | ASCII text | 128 – 159 |
| 8 | Block | ASCII text | 160 – 191 |
| 9 | Survey Area Name | ASCII text | 192 – 223 |
| 10 | Contract Number | ASCII text | 224 – 255 |
| 11 | License ID | ASCII text | 256 – 287 |
| 12 | Survey Type | ASCII text | 288 – 307 |
| 13 | Acquisition Contractor | ASCII text | 308 – 339 |
| 14 | Acquisition Dates (from-to) | ASCII text | 340 – 364 |
| 15 | Job Identification | ASCII text | 365 – 396 |
| 16 | Media Sequence Within Record Set | ASCII text | 397 – 402 |
| 17 | Data Type Identifier | ASCII text | 403 – 434 |

| | | | |
|----|------------------------------------------------------------|------------|-----------|
| 18 | Undefined, fill with spaces (ASCII code 32 ₁₀) | ASCII text | 435 – 438 |
| 19 | Number Of Entries In TOC File | ASCII text | 439 – 448 |

The ASCII text fields are left justified, space (‘ ‘, ASCII 32₁₀) padded, unless otherwise specified. ASCII fields may be left blank, i.e. contain only space (‘ ‘, ASCII 32₁₀) if they are not relevant.

If data from multiple surveys are present on the same SEG-D media, most fields of the header may be left blank. If some fields are common to all data, they may be filled in. Note: Storing data from e.g. multiple surveys onto the same tape is not recommended.

- Field 1 **TOC identifier.** Text indicating this is a TOC file. The field should be set to "SEGD TOC FILE" ,
This field is required,
- Field 2 **SEG-D Revision.** Indicates which SEG-D revision data is stored on the media. The field should be set to SD3.0 to indicate SEG-D Revision 3.0. Must be identical to the SEG-D Revision (Field 2) of the Tape Label of this storage unit (i.e. tape/disk file). *This field is required.*
- Field 3 **Serial number.** Must be identical to the Serial Number (Field 8) of the Tape Label of this storage unit (i.e. tape/disk file). *This field is required.*
- Field 4 **Client Identification.** The name of the client. Must match General Header #6 of the SEG-D records (if present).
- Field 5 **Vessel/Crew Identification.** The name of the vessel or crew acquiring the data. Must match General Header #4 of the SEG-D records (if present).
- Field 6 **Country.** The name of the country the data was acquired in. If multiple countries are involved, they should all be listed here.
- Field 7 **Region.** The region of the country the data was acquired in.
- Field 8 **Block.** The block name of the survey area. If multiple blocks are involved, they should all be listed.
- Field 9 **Survey Area Name.** The name of the survey area. Must match General Header #5 of the SEG-D records (if present).
- Field 10 **Contract Number.** The number/name of the survey contract.
- Field 11 **License ID.** The license identification of the survey area.
- Field 12 **Survey Type.** The type of survey, the presently recommended are:
 - "TOWED MARINE SEISMIC"
 - "LAND SEISMIC "
 - "TRANSITION ZONE "
 - "SEABED SEISMIC "
 - "VERTICAL SEISMIC "
 - "ELECTROMAGNETIC "
 - "COMBINATION "
 - "OTHER "

The COMBINATION survey is any combination of the survey types, e.g. combined TOWED MARINE

and ELECTROMAGNETIC. Other strings may be used if this increases the usability of the TOC file, however it is recommended to use the standardized strings whenever possible.

- Field 13 **Acquisition Contractor.** The (legal) name of the acquisition contractor. Must uniquely identify the acquisition contractor.
- Field 14 **Acquisition Dates (To-From).** The range of dates of the data on this media. If data from only one day is stored, to and from date is set to same date. The format is “DD-MMM-YYYY – DD-MMM-YYYY”, e.g. “03-JAN-2009 – 04-JAN-2009”
- Field 15 **Job Identification.** The acquisition contractor job name/number/identification for the survey. Must match General Header #7 of the SEG-D records (if present).
- Field 16 **Media Sequence Within Record Set.** The sequence of this storage media within this record set. The sequence starts counting at 1, and is increased with 1 for each storage media (e.g. tape) for the record set (e.g. sequence or swath). For storage media with data from multiple record sets, this field is set to “1”.
- Field 17 **Data Type Identifier.** The data type identifier states which type of data is present on this storage media. The acquisition system can freely define the contents. Example: “RAW SEISMIC ORIGINAL DATASET 1”, “ROT/FILT DATASET COPY 2”.
- Field 19 **Number Of Entries In TOC File.** The number of TOC entries following this header. Field format is right justified, space (‘ ’, ASCII 32₁₀) padded integer value. *This field is required.*

4.2.2 TOC Record Entry

| Field | Description | Data type | Start – end byte |
|-------|-----------------------------------|------------|------------------|
| 1 | Media File Number | ASCII text | 1 – 8 |
| 2 | Record Within File | ASCII text | 9 – 15 |
| 3 | Time of shot | ASCII text | 16 – 35 |
| 4 | SEG-D File Number | ASCII text | 36 – 45 |
| 5 | Record ID | ASCII text | 46 - 50 |
| 6 | Record Set Number | ASCII text | 61 – 70 |
| 7 | Line identification (name/number) | ASCII text | 71 – 94 |
| 8 | User defined. | ASCII text | 95 – 128 |

The ASCII text fields are right justified, space (‘ ’, ASCII 32₁₀) padded, unless otherwise specified. ASCII fields may be left blank, i.e. contain only space (‘ ’, ASCII 32₁₀) if they are not relevant.

- Field 1 **Media File Number.** This field is the media file number containing the SEG-D record. Field format: Unsigned integer. The number starts counting from 1. The Tape Label has Media File Number 1, the first SEG-D record is usually contained in Media File Number 2. *This field is required.*

- Field 2 **Record Within File.** Multiple SEG-D records may be stored within one single media file (though this is not recommended for field tapes). Record Within File starts counting from 1, i.e. the first SEG-D record has Record Within File = 1 (and starts at byte 0 of the media file). Field format: Unsigned integer. *This field is required.*
- Field 3 **Time Of Shot.** This field is identical to the Time Zero of the SEG-D record (General Header Block #3, bytes 1–8), and matches the timestamp in General Header Block #1 (bytes 11–16). Field format: Signed integer. *This field is required.*
- Field 4 **SEG-D File Number.** The SEG-D file number as listed in the General Header of the SEG-D record (bytes 1–2 of General Header Block #1, or bytes 1–3 of General Header Block #2). Field format: Unsigned integer. *This field is required.*
- Field 5 **Record ID.** The record ID identifies the record within the record set. Field format: Signed floating point value, some examples: “4” “4.0” “4.000” “-4.0512”. This may be the shot point or source point number if available, but can be any number that identify this record within the record set.
- Field 6 **Record set number.** The record set this SEG-D record belongs to. Must be the same as bytes 21-22 of General Header #2. Field format: Unsigned integer.
- Field 7 **Line identification (name/number).** The line number or name of the line the record belongs to. For surveys where both receiver and source line numbers exists, it is recommended to set this field to the source line number whenever possible. Set to empty (all spaces, ASCII 32₁₀) if not valid. Must match General Header #8 Line Identification field of the SEG-D record (if present). Field is left justified space (‘ ’, ASCII 32₁₀) padded ASCII string.
- Field 8 **User defined.** 34 bytes of user defined ASCII text. The field can be freely utilized by the recorder, but the contents must be ASCII text. Record as empty (fill with space (‘ ’, ASCII 32₁₀) if not used).

TOC file size calculation example:

Size of shot:

5000 channels, 10 seismic seconds (i.e. 10240 milliseconds) record length, SEG-D 8036 format (3 byte per sample) and 2 millisecond sampling rate. All traces recorded for the full record time, each trace has five 32 byte Trace Header Extension blocks. (For simplicity we ignore the SEG-D record header, it is assumed to be small compared to the data).

$$5000 * (10240 / 2 * 3 + 5 * 32 + 20) = 77700000 \text{ bytes} = 74.1 \text{ MB}$$

Size of tape:

300 000 MB (or ~300 GB)

Size of table of contents file:

$$448 + 300000/74.1 * 128 = \underline{507 \text{ kB}} \text{ (approximately)}$$

The recorder of this dataset will need to leave 507 kilobytes of space at the end of a 300 GB tape for storing the TOC file.

4.2.3 Using the TOC with SEG-D on disk

The Table of Contents is designed to aid in rapid access to data stored on tape and other sequential record-oriented media where random access to arbitrary byte locations on the media is unavailable. For SEG-D datasets created as one huge contiguous byte stream disk file, the TOC would be trivial and of quite modest utility, with just a list of TOC Record entries showing the SEG-D File Numbers in that file, but providing no way of locating those records short of reading through the disk file until the desired record is encountered (note that the reading is quite simple though as GeneralHeader #3 contains size of record allowing fast jump to next record). For this reason, as well as to limit the loss of data should a disk file be corrupted, we recommend that SEG-D data be created directly on disk in the following manner:

- The SEG-D Storage Unit Label and each Record should be written to a separate disk file.
- The naming convention of these files should include the numeric Media File Number from the TOC Record Entry field. We also recommend the disk file name include the Record Set Number from that same TOC Record Entry and the Media Sequence Within Record Set from the TOC Header prepended before the Media File Number.

For SEG-D records copied to disk from tape, the existing TOC is copied to a disk file of its own. In order for this copied TOC to be immediately valid for the disk copy, we recommend the data be copied to disk in the following manner:

- Each individual tape file (which may include multiple SEG-D File Numbers) should be copied to a separate disk file. A dummy SEG-D Storage Unit Label must be prepended the data. It is recommended that the dummy label is based on the tape Storage Unit Label, but modifications done such that it will not be confused with the real tape data. It is however strongly recommended to include a reference to the original tape media in the dummy label, e.g. by utilizing the “User defined” portion of the Storage Unit Label.
- The naming convention of these files should include the numeric Record Set Number, the Media Sequence Within Record Set and Media File Number from the existing TOC.

For ease of listing and sorting, the numeric fields embedded in the file names should each be of a fixed length, with leading zeros padded instead of blanks, so as to accommodate the largest possible value for that field. So, for example, if we use the template FILE_[rsn]_[mseq]_[mfn].SGD for file names, the Record Set Number (rsn) should be 5 digits long, the Media Sequence Within File (mseq) should be 6 digits long, and the Media File Number 8 digits long. This results in a file name of 29 characters, quite manageable on all modern computer systems.

Note: There are a lot of other ways of storing SEG-D data on disk, for example storing each individual tape file as a disk file in a filesystem directory. This is perfectly legal, and may be very useful for internal data storage, but it is not considered proper SEG-D data as each disk file does not start with a Storage Unit Label and the data can not be treated as a stream of bytes (each disk file must be read separately).

5.0 Header blocks

The headers are blocks of data prior to the seismic data which contain auxiliary information about the seismic data, the acquisition parameters, acquisition geometry, and user-defined information. The header block includes at least three General Header Blocks, zero or more Scan Type headers, and optional Extended and External headers. Trace Headers are included in conjunction with each seismic data trace. Sections 7 and 8 detail the content of each type header.

In addition to header blocks which are recorded prior to the seismic data traces, an optional General Trailer is allowed following the seismic data. This allows recording other auxiliary information which is not available at the beginning of the record. Sections 7 and 8 include detailed description of the allowed fields of the General Trailer.

5.1 General Headers (General Header Block #1, #2 and #3 are required)

General Header Block #1 is 32 bytes long and contains information similar to SEG A, B, C, and the original SEG-D headers. Abbreviations are as close as possible to those used in previous formats.

SEG-D, Rev 3.0 requires the use of General Header Block #1, General Header Block #2 (as was also required in SEG-D, Rev 2.x), and General Header #3 (new with SEG-D, Rev 3.0). The General Headers define basic parameters for the record such as file number, time of record, number of channel sets, sizes of meta and auxiliary data, etc. General Header Block #2 allows extended values exceeding the limits of General Header Block #1; the values of General Header Block #1 are then set to FF_{16} to indicate the actual value will be found elsewhere. Note that the Rev 2.1 Sequence Number has been renamed Record Set Number to be applicable for non-towed marine operations. For towed marine operations, the sequence number should be entered in that field. General Header Block #3 contains an accurate timestamp for the record in addition to size information for the record to allow quick searching through the record.

Bytes 1–3 in General Header Block #2 allow for a three byte, binary file number. To use this extended file number, bytes 1 and 2 in General Header Block #1 must be set to $FFFF_{16}$.

General Header Block #2 also allows for a two byte, binary number of Channel Sets/Scan Type in bytes 4 and 5. When using the Extended Channel Sets/Scan Type, byte 29 of the General Header Block #1 must be set to FF_{16} .

Additional blocks may be added as needed by the manufacturer or user.

Rev 3.0 has a much more flexible information structure in the General Header than Rev 2.x. All General Header blocks except General Header Blocks #1–3 are optional, and can appear in any order, and a lot more information can be entered. (Rev. 3.0 allows up to 65535 General Header blocks, compared to the 15 allowed in Rev. 2.x). To achieve this, byte 32 of all header blocks have been assigned an ID depending on its contents. The following are currently defined:

| ID (Byte 32) | Contents (Block Name) | Additional General Headers | Scan Type Headers | Trace Headers | General Trailer |
|------------------|----------------------------------------------|----------------------------------|-------------------------|------------------|--------------------|
| 02 ₁₆ | General Header 2 | * | | | |
| 03 ₁₆ | General Header 3 (Timestamp and size header) | * | | | |
| 10 ₁₆ | Vessel/Crew identification | * | | * | |
| 11 ₁₆ | Survey Area Name | * | | * | |
| 12 ₁₆ | Client Name | * | | * | |
| 13 ₁₆ | Job identification | * | | * | |
| 14 ₁₆ | Line Identification | * | | * | |
| 15 ₁₆ | Vibrator Source Information | * | | * | |
| 16 ₁₆ | Explosive source information | * | | * | |
| 17 ₁₆ | Airgun source information | * | | * | |

| | | | | | |
|-------------------------------------|--------------------------------------------------|---|---|---|---|
| 18 ₁₆ | Watergun source information | * | | * | |
| 19 ₁₆ | Electromagnetic source | * | | * | |
| 1F ₁₆ | Other source type information | * | | * | |
| 20 ₁₆ | Additional source information | * | | * | |
| 21 ₁₆ | Source Auxiliary Channel Reference | * | | * | |
| 30 ₁₆ | Channel set description block 1 | | * | | |
| 31 ₁₆ | Channel set description block 2 | | * | | |
| 32 ₁₆ | Channel set description block 3 | | * | | |
| 40 ₁₆ | Demux Trace header extension 1 | | | * | |
| 41 ₁₆ | Sensor Info header extension block | * | | * | |
| 42 ₁₆ | Time Stamp Header block | | | * | |
| 43 ₁₆ | Sensor calibration block | * | | * | |
| 44 ₁₆ | Time drift block | * | | * | |
| 45 ₁₆ | Electromagnetic Src/Recv desc block | * | | * | |
| 50 ₁₆ | Position block 1 | * | | * | |
| 51 ₁₆ | Position block 2 | * | | * | |
| 52 ₁₆ | Position block 3 | * | | * | |
| 55 ₁₆ | Coordinate Reference System Identification block | * | | * | |
| 56 ₁₆ | Relative position block | * | | * | |
| 60 ₁₆ | Orientation Header block | * | | * | |
| 61 ₁₆ | Measurement block | * | | * | |
| 70 ₁₆ | General Trailer Description Block | | | | * |
| B0 ₁₆ – FF ₁₆ | User defined header block | * | | * | |

Table 2: Header block types defined in SEG-D Rev 3.0

Note the table contains all standard defined header types, including those used in trace headers. This is done to allow the same information to be inserted into a General Header or a Trace Header, depending on what is most useful. The ‘*’ marks which blocks can be inserted in which parts of the SEG-D structure. Please note:

- The Scan Type Header/Channel Set Descriptors is following the General Header blocks, and should only contain Channel Set Description block 1-3. No other block types should be inserted in the Scan Type Header.
- The ordering of blocks is used to indicate what the information in the block refers to, e.g. a Position Block (50₁₆-52₁₆) following a Vibrator Source Information block (15₁₆) describes the position of the specified vibrator.
- The General Trailer consists of manufacturer specified blocks separated by General Trailer Description blocks, which means any other information, including the header blocks above, may be stored in the General Trailer.
- The table above gives a guide to where the blocks can be stored, however each manufacturer must determine what is most useful in each case. For example storing Survey Area Name (11₁₆) may not make much sense in most cases.

And note:

Though there is support for user-defined block types, we recommend using only standard header blocks in the General Header, and placing user-defined information into an Extended or External header. These have much more available space available and allow a more flexible format. User-defined blocks are really intended to be used in the Trace Header.

The General Header is a sequence of 32 byte blocks of different types, identified by the ID in byte 32, describing general information about the entire record.

Information blocks commonly inserted into a General Header are Vessel/Crew Identification (10₁₆), Survey Area Name (11₁₆), Client Name (12₁₆), Job Identification (13₁₆), and Line Identification (14₁₆).

If the record is related to a single source event (shot), we recommend inserting information regarding the source (IDs 15₁₆–19₁₆ or 1F₁₆ depending on source type) into a General Header. If multiple source events occur in the record, e.g. in land slip-sweep operations, storing the source information in the relevant auxiliary source trace headers can be done.

To be able to associate information to the correct source (in General Header or Trace Header), the header blocks should be ordered such that all information regarding one source is grouped together, followed by information related to the next source etc. This is crucial when dealing with blocks not containing the Source ID like the Position Block. This can schematically be summarized like this:

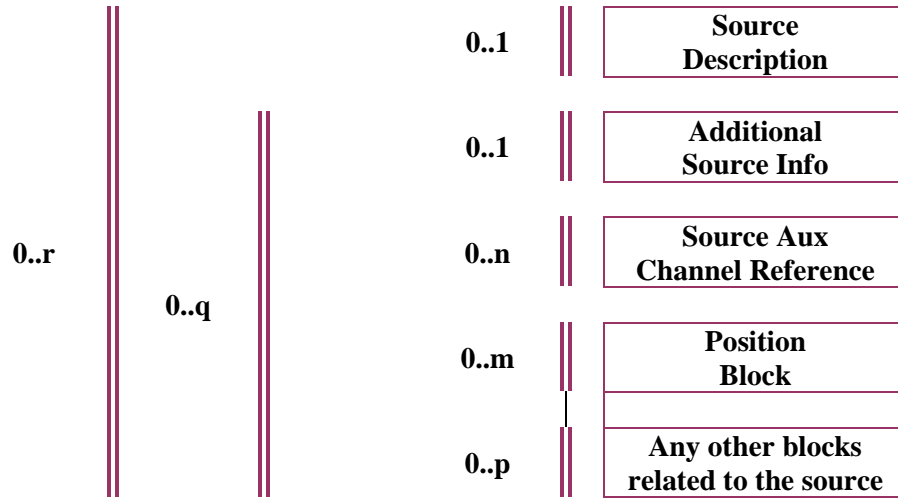

For more information regarding the use of Source Description blocks, please refer to example E.7.

Note:

Source information (e.g. Additional Source Info or Source Aux Channel Reference) may appear in Trace Headers without a Source Description block in front, however there must then be a Source Description block for that source in General Header. It is not allowed to store source information in General Header without a Source Description block.

5.2 Scan Type Headers

The Scan Type Header is used to describe the information about the recorded channels (filters, sampling intervals, sample skew, etc.). The Scan Type Header is composed of one or more channel set descriptors followed by skew information. The channel set descriptors must appear in the same order as their respective channel sets will appear within a base scan interval. A channel set, which is part of a scan type, is defined as a group of channels all recorded with identical recording parameters. One or more channel sets can be recorded concurrently within one scan type. In addition, there can be multiple scan types to permit dynamic scan type changes during the record (e.g., 12 channels at 1/2 ms switched at about 1 second to 48 channels at 2 ms). Where there are dynamic changes, Scan Type Header #1 describes the first part of the record, Scan Type Header #2 the second part, etc. Within the Scan Type Header, each channel set descriptor is composed of a 96 byte field, and up to 65535 channel set descriptors may be present. In addition, up to 99 scan type headers may be utilized in a record.

Following the channel set descriptors of a scan type are a number of 32 byte fields (SK, specified in byte 30 of General Header #1) that specify sample skew. Sample skew (SS) is recorded in a single byte for each sample of each subscan of each channel set, in the same order as the samples are recorded in the scan. Each byte represents a fractional part of the base scan interval (Byte 23 of General Header #1). The resolution is 1/256 of this interval. For instance, if the base scan interval is 2 msec, the least significant bit in the sample skew byte is 1/256 of 2 msec or 7.8125 microseconds.

A channel set is a group of channels that:

- a) Use identical recording parameters. This includes the same record length and sampling interval.
- b) Use identical processing parameters, including the same filter selection and array forming parameters.
- c) Originates from the same streamer cable for marine data. The streamer cable number for each channel set is included in the channel set descriptor byte 31.
- d) Consists of channels with the same group spacing. For example, if one streamer has short group spacing close to the boat and longer group spacing at long offsets, the data from the streamer would be recorded as two channel sets. The first channel in each channel set will start with trace number one.

The following is a list of ground rules for the scan type header:

1. The order in which channel sets are described in the header will be the same as the order in which the data are recorded for each channel set.
2. In a Scan Type Header containing multiple channel set descriptors with different sampling intervals, each channel set descriptor will appear only once in each scan type header. Within the data block, however, shorter sampling interval data are recorded more frequently.
3. In the case of multiple scan type records, such as the dynamically switched sampling interval case, each scan type will contain the same number of channel sets. Any unused channel sets needed in a scan type must be so indicated by setting bytes 21 to 23 (channels per channel set) to zero in the channel set descriptor.
4. In multiple scan type records, the number of bytes per base scan interval must remain a constant for all scan types recorded.
5. Channels within the same Channel Set must now have the same number of Trace Header Extensions. Since all traces within a Channel Set will contain the same number of Trace Header Extensions, the number of Trace Header Extensions will be indicated in the Channel Set Descriptor. Byte 28 of the Channel Set Descriptor contains the number of Trace Extension Headers in the channel set. This must match the byte 10 of the Demux Trace Header of traces in the channel set. Each trace is hence limited to a maximum of 255 Trace Header Extension blocks.
6. The length of each trace within a Channel Set is restricted to be the same value. This limitation and the restriction of the number of Trace Header Extensions to the same number within a Channel Set will result in each trace within a Channel Set being recorded with the same number of bytes.

5.3 Demux Trace Header (required)

The Demux Trace Header length is 20 bytes and is an identifier that precedes each channel's data. The trace header and the trace data are recorded as one block of data. A trace is restricted to one channel of data from one channel set of one scan type. Some of the information in the trace header is taken directly from the general header and the scan type header.

Bytes 7, 8, and 9 comprise the timing word that would accompany the first sample if these data were written in multiplex format. To obtain the exact sample time, the actual sample skew time (Byte 11 multiplied by the base scan interval) must be added to the time recorded in Bytes 7, 8, and 9.

The timing word is in milliseconds and has the following bit weight assignments:

Timing word

| Bit | 0 | 1 | 2 | 3 | 4 | 5 | 6 | 7 |
|--------|----------|----------|----------|----------|----------|----------|----------|----------|
| Byte 7 | 2^{15} | 2^{14} | 2^{13} | 2^{12} | 2^{11} | 2^{10} | 2^9 | 2^8 |
| Byte 8 | 2^7 | 2^6 | 2^5 | 2^4 | 2^3 | 2^2 | 2^1 | 2^0 |
| Byte 9 | 2^{-1} | 2^{-2} | 2^{-3} | 2^{-4} | 2^{-5} | 2^{-6} | 2^{-7} | 2^{-8} |

The timing word LSB (2^{-8}) is equal to 1/256 msec, and the MSB (2^{15}) is equal to 32,768 msec. The timing word for each scan is equal to the elapsed time from zero time to the start of that scan. Timing words from 0 to 65535.9961 msec can be encoded. For longer recordings the timing word may overflow to zero and then continue.

The first scan of data has typically started with timing word zero. However, this is not a requirement. In a sampling system, it is not always practical to resynchronize the system even though most seismic data acquisition systems have to date. Possible reasons for not wanting to resynchronize could be digital filtering, communication restrictions, etc.

Whether the system is resynchronized or not, the timing word will contain the time from the energy source event to the start of scan of interest. For example, assume the sampling interval is 2 msec, the system does not resynchronize, and the energy source event occurs $1 + 9/256$ msec before the next normal start of scan. The timing word values would be:

| | |
|----------------------------|-------------------------|
| First timing word | $0 + 1 + 9/256$ msec |
| Second | $2 + 1 + 9/256$ msec |
| Third | $4 + 1 + 9/256$ msec |
| Fourth | $6 + 1 + 9/256$ msec |
| ... | ... |
| One-thousandth timing word | $1998 + 1 + 9/256$ msec |

Byte 11 contains sample skew of the first sample of this trace. This is identical to the first byte of sample skew for this channel in the Scan Type Header.

Bytes 13, 14, 15 are included as an integrity check on time break. They comprise the timing word of the scan in which Time Break Window Indicator (TWI) changed to a one. Thus, it represents the time from the time break to the end of the time break window. Random variations in this time indicate a problem in the fire control system. The presence of a value less than the base scan interval indicates that time break was not detected and recording commenced at the end of the time break window.

The definition of the timing word is kept the same between Rev 2.1 and Rev 3.0, even though the possible sample rates have decreased to 1 microsec. The reason is that timing words are needed for historical reasons, and modern acquisition systems supporting high sample rate data are assumed to use synchronization techniques not requiring the use of timing word.

A Trace Header Extension may be added to include the receiver location for that trace. Receiver locations are defined by a receiver line number (three integer bytes and two fraction bytes), a receiver point number (three bytes integer and two bytes fraction) and a receiver point index (one byte). This index allows one to define the receiver group in the grid, the original value being 1 and that value is incremented by 1 every time the receiver is moved, even when it is moved back to the previous location. The reshoot index should be used to indicate a reacquisition of a previously acquired trace, counting from 0, an increasing with 1 every time the trace is re-acquired. The group index is used to indicate that the trace is part of a group that must be processed as a unit, e.g. rotation for multi-component data. The depth index is used to support sensors in different vertical positions. Please refer to appendix E.6 for examples of use of indexes. The Sensor Type (vertical geophone, hydrophone, etc.) may be indicated in Byte 21.

Additional trace header blocks (e.g. source information, positions, orientation blocks, or manufacturer defined blocks) may be added as needed by the manufacturer or user. The maximum number of Trace Header Extensions is limited to 255.

A larger number of samples per trace may be recorded using bytes 25–28 of the first Trace Header Extension.

5.4 Extended Header (optional)

The Extended Header provides additional areas to be used by equipment manufacturers to interface directly with their equipment. Since the nature of this data will depend heavily on the equipment and processes being applied, it will be the responsibility of the equipment manufacturer to establish a format and document this area. Byte 31 of General Header Block #1 contains the number of 32 byte fields in the Extended Header. If more than 99 Extended Header blocks are used, then General Header Block #1, byte 31 is set to FF₁₆ and bytes 6 to 8 in the General Header Block #2 indicate the number of Extended Header Blocks.

5.5 External Header (optional)

The External Header provides a means of recording special user-desired information in the header block. This data format will be defined and documented by the end user. The means of putting this information into the header has usually been provided by the equipment manufacturer. Byte 32 of General Header Block #1 contains the number of 32 byte fields in the external header. If more than 99 External Header blocks are used, then General Header Block #1, Byte 32 is set to FF₁₆ and Bytes 28 to 30 of General Header Block #2 indicates the number of External Header blocks.

5.6 General Trailer (optional)

Following the seismic data, a General Trailer may be recorded. This provides for recording auxiliary system and navigation related data. The addition of the trailer will allow the accumulation of system faults, data QC information, real-time navigation position, and timing information on the same record and contiguous with the shotpoint to which it relates. By recording this data after all of the other data, additional time is provided for collecting the data and transferring it to the recording system. The General Trailer consists of a set of blocks consisting of a short header followed by a number of data blocks. All information in the General Trailer is optional, and each block may be formatted as desired by the manufacturer or user. The number of General Trailer blocks is indicated in bytes 13 to 16 of General Header Block #2.

To aid with the transfer of information between acquisition and processing, a few types of trailer blocks have been defined:

1. Edits
2. Navigation data backup
3. Text comments
4. Observer log

We recommended using these standard formats when inserting this type of information in the trailer.

Note: All types of trailer records are optional.

5.6.1 Edit (SEG-D Trace Edit v1.0)

Block Type (byte 1) is set to 01₁₆, ASCII/binary (byte 2) set to 02₁₆ and Description (byte 9–24) set to "TRACE EDIT v1.0".

The edits trailer allows the recorder to modify the trace information provided by the trace header in the record. This is typically used to indicate problems with certain traces. Edits trailer blocks are typically generated post acquisition, during

the QC and processing stages. SEG-D Rev 3 allows multiple Edit trailer blocks to be defined. The information in later Edit blocks overrides information in earlier blocks.

The format presented here is similar to the one described in [*SEG ADS Trace Edit, Norris, Hares, Faichney, 2001, SEG-UKOOA Ancillary Data Standard - ADS Trace Edit: Geophysics, 66, no. 06, 2040–2054*], though some modifications/simplifications have been done. The SEG ADS Trace Edit format is very flexible, and some adaptation must be done to make it fit the SEG-D record structure. In addition, the format of some fields had to be more strictly defined to enable automatic parsing of the format.

It is recommended that the recording system creates Edit records to indicate which traces are bad, even though this is also indicated in the trace headers. This will give a quick overview of the shot without the need for scanning through all the data, and will simplify importing of data into processing/QC systems.

Multiple Edit records may exist. The latter will override prior definitions.

The edit format is ASCII, to ease human readability.

The format consists of multiple lines, each line terminated with a newline terminator consisting of a Line Feed ('\n', 0A₁₆) or Carriage Return/LineFeed ('\r\n', 0D0A₁₆).

From here on, <LF> is used to indicate newline, <space> to indicate the space character (20₁₆).

Each line (record) consists of a record description letter followed by space (20₁₆), then some ASCII text, and terminated by linefeed.

<Record function><space>ASCII text<LF>

The Edit block is padded with <space> until a multiple of 32 byte is reached.

| Class | Record Function Character | Description |
|--------------------|---------------------------|-----------------------------------------------------------------------------------------------------------------------|
| Header | V | SEG-D Trace Edit version (required) |
| Header | C | Comment |
| Header | S | Timestamp, UTC (required) |
| Header | W | System/person to generate this edit (required) |
| Header | A | Attribute definition and range (at least one A record is required) |
| Header | P | Parameters for attribute, if one line is not enough to describe the attribute (optional) |
| Header | H | Header, description of a test (required) |
| Header | R | Range of traces tested. A test may not be applicable to all traces. If not present, all traces are tested. (optional) |
| Header | Y | Severity of exclusion. If not present, trace is to be removed (not to be processed) (Optional) |
| Primary Key Record | X | Exclude these trace ranges. May be several |

| Class | Record Function Character | Description |
|--------------------|---------------------------|-----------------------------------------------------------------------------------------------------------------------------------------------------------|
| | | for each header. |
| Primary Key Record | I | Include these trace ranges. May be several for each header. I records may be used to override X record settings (though this is considered bad practice). |
| Terminator | E | End of Header/Primary Key record pair (at least one E record is required) |
| Terminator | T | End of SEG-D Trace Edit dataset (one and no more than one T record is required) |

An edit record will consist of a header (V/S/W/C records), then for each test H/A/P/Y/R/X/I/E/C and optionally S/W if the test was performed in another system/at another time.

The format of all fields are defined by the recorder, except V/S/Y/R/X/I. However there are three requirements:

- *System recognition*: All systems must be able to determine which traces have been edited, when, by who, and how serious the edit is.
- *System regeneration*: The system creating the edit must be capable of parsing the edit, and recreate the test based on the information in the edit records. No other information must be required.
- *Human readability*: The edits should be human readable. Use C records if the system generated text is not enough.

Format of fields

SEG-D Trace Edit version

Format:

V<space>SEGD Trace Edit v<major>.<minor><LF>

This version of trace edit is 1.0.

Example:

V SEGD Trace Edit v1.0

Time stamp

This is the time of the edit Timestamp in UTC, accuracy 1 second.

Format:

S<space><hour>:<minute>:<second> <monthday>-<month three letter abbreviation>-<year 4 digits><LF>

Example:

S 13:35:00 23-MAR-2007

Severity of exclusion

What to do with the trace failing the test described in the A record.

Y<space><severity><LF>

The following severities exist:

- EXCLUDE - The traces listed in X record should be excluded from further processing (default)
- WARNING - The traces listed in X records are suspicious, and further investigation is recommended.

Example:
 Y WARNING
 Y EXCLUDE

Trace range definition

Used to define ranges of traces to test (R), include (I) or exclude (X).

Format :

```
<record letter><space><scanset NUMBER LIST;<channelset NUMBER LIST>;<trace NUMBER LIST><LF>
```

NUMBER LIST is a comma separated list of numbers, or ranges. For example 1,4,10-14 means numbers 1, 4, and 10 through 14.

Example:

```
R 1-1, 5-14, 1-558  

X 1-1, 5-14, 1-5  

I 1-1, 8-11, 5-5
```

The ranges checked are traces 1-558 in channel sets 5-14 (e.g. the seismic channel sets for a 10 streamer vessel). X record states traces 1-5 on all streamers fails the test (e.g. due to noise), but I record overrides, and indicates channel 5 in channel set 8-11 passed.

See Appendix E.7 for a complete example of a Trace Edit v1.0 block.

5.6.2 Navigation data backup

Trailer block used as a backup of navigation related information. The contents is defined by the following table

| Contents | Block type | ASCII/ binary | Description |
|-----------------------------------|------------------|--------------------------|--------------------|
| P1 processed navigation data | 20 ₁₆ | 02 ₁₆ (ASCII) | "P1 FILE FORMAT " |
| P2 Raw marine positioning data | 21 ₁₆ | 02 ₁₆ (ASCII) | "P2 FILE FORMAT " |
| P3 Land survey field data | 22 ₁₆ | 02 ₁₆ (ASCII) | "P3 File Format " |
| P5 Pipeline positioning data | 23 ₁₆ | 02 ₁₆ (ASCII) | "P5 FILE FORMAT " |
| P6 3D seismic binning grids | 24 ₁₆ | 02 ₁₆ (ASCII) | "P6 FILE FORMAT " |
| P7 Well deviation data | 25 ₁₆ | 02 ₁₆ (ASCII) | "P7 FILE FORMAT " |
| SPS Shell Processing Support data | 26 ₁₆ | 02 ₁₆ (ASCII) | "SPS FILE FORMAT " |
| SEG-Y Extended Textual Stanza | 27 ₁₆ | 02 ₁₆ (ASCII) | "SEGY TEXT STANZA" |

A whole file is added in a trailer block as described above. If multiple files need backing up, several trailer blocks may be added.

5.6.3 Text Comment

Block Type (byte 1) is set to 10₁₆, ASCII/binary (byte 2) set to 02₁₆ and Description (bytes 9-24) set to "TEXT COMMENT ".

This trailer block contains any user defined, textual comment belonging to the SEG-D record. May be multiple lines, each line terminated with Line Feed ('\n', 0A₁₆), or optionally Carriage Return/LineFeed ("\r\n", 0D0A₁₆).

Multiple text comments may exist.

Text comments are padded with spaces (20₁₆) until a multiple of 32 bytes is reached.

5.6.4 Observer log

Block Type (byte 1) is set to 11₁₆, ASCII/binary (byte 2) set to 02₁₆ and Description (bytes 9–24) set to "OBSERVER LOG".

This is the observer log entry for this record. The format is textual.

Observer logs are padded with spaces (20₁₆) until a multiple of 32 bytes is reached.

5.6.5 User defined

The contents of the user defined block is completely left to the recording system, however the size must be a multiple of 32 bytes. The format is textual or binary as defined by the ASCII/binary flag in the description block. Byte 1 should be set to a value between A0₁₆ and FF₁₆.

6.0 Data Body

Data is recorded as a byte stream in demultiplexed format. Preceding each trace of data is a trace header, a trace header extension #1 and optional trace header extensions. Each trace is a sequential set of samples from one channel in one channel set.

6.1 Data Recording Method

To accommodate diverse recording needs, the data recording allows sample representations of 8, 16, 20, 24, 32, and 64 bits.

The data word is a numeric representation of the sign and magnitude of the instantaneous voltage presented to the system. It is not an indication of how the hardware gain system functions. The output of stepped gain systems may be represented as a binary mantissa and a binary exponent of base 2, 4, or 16 (binary, quaternary, or hexadecimal system) or a simple integer value. Depending upon the particular recording method, the mantissa or integer may be represented as a sign-magnitude, one's complement, or two's complement binary value. In a sign-magnitude representation, the initial bit is set to 1 if the value is the negative of the number represented by the remaining bits and 0 otherwise. A one's complement binary value is the same as sign-magnitude for nonnegative numbers but all the bits are flipped (XOR'ed with 1's) to represent negative values. A nonnegative value in two's complement representation is also the same as sign-magnitude, but negative numbers are represented by first flipping all the bits and then adding 1. If a two's complement number has n bits, then its value can be determined by first adding 2^{n-1} , taking the result modulo 2^n , and finally subtracting 2^{n-1} .

Following are descriptions of each of the data recording methods permitted. The same number system is to be used on all samples in a record, including auxiliary and all other types of channels. All recording methods are valid for demultiplexed records; as of Rev 1 SEG-D no longer supports multiplexed data.

1 byte quaternary exponent data recording method

The following illustrates the 8 bit word and the corresponding bit weights:

| Bit | 0 | 1 | 2 | 3 | 4 | 5 | 6 | 7 |
|--------|---|----------------|----------------|----------------|-----------------|-----------------|-----------------|-----------------|
| Byte 1 | S | C ₂ | C ₁ | C ₀ | Q ₋₁ | Q ₋₂ | Q ₋₃ | Q ₋₄ |

S=sign bit. —(One = negative number).

C=quaternary exponent.—This is a three bit positive binary exponent of 4 written as 4^{CCC} where CCC can assume values from 0–7.

*Q₋₁₋₄*fraction.—This is a 4 bit one's complement binary fraction. The radix point is to the left of the most significant bit (Q₋₁) with the MSB being defined as 2^{-1} . The fraction can have values from $-1+2^{-4}$ to $1-2^{-4}$.

Input signal = S.QQQQ $\times 4^{\text{CCC}}$ \times DSM millivolts where DSM is the value required to descale the data sample to the recording system input level. DSM is defined in Bytes 17–20 of each channel set descriptor in the scan type header.

2 byte quaternary exponent data recording method

The following illustrates the 16-bit word and the corresponding bit weights:

| Bit | 0 | 1 | 2 | 3 | 4 | 5 | 6 | 7 |
|--------|-----------------|-----------------|-----------------|-----------------|-----------------|------------------|------------------|------------------|
| Byte 1 | S | C ₂ | C ₁ | C ₀ | Q ₋₁ | Q ₋₂ | Q ₋₃ | Q ₋₄ |
| Byte 2 | Q ₋₅ | Q ₋₆ | Q ₋₇ | Q ₋₈ | Q ₋₉ | Q ₋₁₀ | Q ₋₁₁ | Q ₋₁₂ |

S=sign bit.—(One = negative number).

C=quaternary exponent.—This is a three bit positive binary exponent of 4 written as 4^{CCC} where CCC can assume values from 0–7.

Q₋₁₋₁₂ fraction.—This is a 12 bit one's complement binary fraction. The radix point is to the left of the most significant bit (Q₋₁) with the MSB being defined as 2⁻¹. The fraction can have values from -1 + 2⁻¹² to 1 - 2⁻¹².

Input signal = S.QQQQ,QQQQ,QQQQ × 4^{CCC} × DSM millivolts where DSM is the value required to descale the data sample to the recording system input level. DSM is defined in Bytes 17–20 of each channel set descriptor in the scan type header.

2½ byte binary exponent data recording method—demultiplexed

The following illustrates the 20 bit word and the corresponding bit weights:

| Bit | 0 | 1 | 2 | 3 | 4 | 5 | 6 | 7 | |
|---------|-----------------|-----------------|------------------|------------------|------------------|------------------|------------------|------------------|---------------------------------------------|
| Byte 1 | C ₃ | C ₂ | C ₁ | C ₀ | C ₃ | C ₂ | C ₁ | C ₀ | Exponents for samples 1 thru 4 [†] |
| Byte 2 | C ₃ | C ₂ | C ₁ | C ₀ | C ₃ | C ₂ | C ₁ | C ₀ | |
| Byte 3 | S | Q ₋₁ | Q ₋₂ | Q ₋₃ | Q ₋₄ | Q ₋₅ | Q ₋₆ | Q ₋₇ | Sample 1 |
| Byte 4 | Q ₋₈ | Q ₋₉ | Q ₋₁₀ | Q ₋₁₁ | Q ₋₁₂ | Q ₋₁₃ | Q ₋₁₄ | Q ₋₁₅ | |
| Byte 5 | S | Q ₋₁ | Q ₋₂ | Q ₋₃ | Q ₋₄ | Q ₋₅ | Q ₋₆ | Q ₋₇ | Sample 2 |
| Byte 6 | Q ₋₈ | Q ₋₉ | Q ₋₁₀ | Q ₋₁₁ | Q ₋₁₂ | Q ₋₁₃ | Q ₋₁₄ | Q ₋₁₅ | |
| Byte 7 | S | Q ₋₁ | Q ₋₂ | Q ₋₃ | Q ₋₄ | Q ₋₅ | Q ₋₆ | Q ₋₇ | Sample 3 |
| Byte 8 | Q ₋₈ | Q ₋₉ | Q ₋₁₀ | Q ₋₁₁ | Q ₋₁₂ | Q ₋₁₃ | Q ₋₁₄ | Q ₋₁₅ | |
| Byte 9 | S | Q ₋₁ | Q ₋₂ | Q ₋₃ | Q ₋₄ | Q ₋₅ | Q ₋₆ | Q ₋₇ | Sample 4 |
| Byte 10 | Q ₋₈ | Q ₋₉ | Q ₋₁₀ | Q ₋₁₁ | Q ₋₁₂ | Q ₋₁₃ | Q ₋₁₄ | Q ₋₁₅ | |

[†]Bytes 1 and 2 contain the exponents for the following four samples of the channel. The sample numbers are relative and are only to denote position in the four sample group.

S=sign bit.—(One = negative number).

C=binary exponent—This is a 4 bit positive binary exponent of 2 written as 2^{CCCC} where CCCC can assume values of 0–15. The four exponents are in sample order for the four samples starting with the first sample in bits 0–3 of Byte 1.

Q₋₁₋₁₅ fraction—This is a 15 bit one's complement binary fraction. The radix point is to the left of the most significant bit (Q₋₁) with the MSB being defined as 2⁻¹. The sign and fraction can assume values from 1 - 2⁻¹⁵ to -1 + 2⁻¹⁵.

Input signal=S.QQQ,QQQQ,QQQQ,QQQQ × 2^{CCCC} × DSM millivolts where DSM is the value required to descale the data word to the recording system input level. DSM is defined in Bytes 17–20 of each of the corresponding channel set descriptors in the scan type header.

Note that in utilizing this data recording method, the number of samples per channel must be exactly divisible by 4 in order to preserve the data grouping of this method.

1 byte hexadecimal exponent data - recording method

The following illustrates the 8-bit word and the corresponding bit weights:

| Bit | 0 | 1 | 2 | 3 | 4 | 5 | 6 | 7 |
|--------|---|----------------|----------------|-----------------|-----------------|-----------------|-----------------|-----------------|
| Byte 1 | S | C ₁ | C ₀ | Q ₋₁ | Q ₋₂ | Q ₋₃ | Q ₋₄ | Q ₋₅ |

S=sign bit.—(One = negative number).

C=hexadecimal exponent.—This is a two positive binary exponent of 16 written as 16^{CC} where CC can assume values from 0–3.

Q₋₁₋₅ fraction—This is a 5 bit positive binary fraction. The radix point is to the left of the most significant bit (Q₋₁) with the MSB being defined as 2⁻¹. The sign and fraction can have any value from -1 + 2⁻⁵ to 1 - 2⁻⁵.

Input signal = (-1)^S × 0.Q,QQQQ × 16^{CC} × DSM millivolts where DSM is the value required to descale the data sample to the recording system input level. DSM is defined in Bytes 17–20 of each channel set descriptor in the scan type header.

2 byte hexadecimal exponent data - recording method

The following illustrates the 16-bit word and the corresponding bit weights:

| Bit | 0 | 1 | 2 | 3 | 4 | 5 | 6 | 7 |
|--------|-----------------|-----------------|-----------------|-----------------|------------------|------------------|------------------|------------------|
| Byte 1 | S | C ₁ | C ₀ | Q ₋₁ | Q ₋₂ | Q ₋₃ | Q ₋₄ | Q ₋₅ |
| Byte 2 | Q ₋₆ | Q ₋₇ | Q ₋₈ | Q ₋₉ | Q ₋₁₀ | Q ₋₁₁ | Q ₋₁₂ | Q ₋₁₃ |

S=sign bit.—(One = negative number).

C=hexadecimal exponent.—This is a two bit positive binary exponent of 16^{CC} where CC can assume values from 0–3.

Q₋₁₋₁₃ fraction—This is a 13 bit positive binary fraction. The radix point is to the left of the most significant bit (Q₋₁) with the MSB being defined as 2⁻¹. The sign and fraction can have any value from -1 + 2⁻¹³ to 1 - 2⁻¹³.

Input signal = (-1)^S × 0.Q,QQQQ,QQQQ,QQQQ × 16^{CC} × DSM millivolts where DSM is the value required to descale the data sample to the recording system input level. DSM is defined in Bytes 17–20 of each channel set descriptor in the scan type header.

4 byte hexadecimal exponent data - recording method

The following illustrates the 32-bit word and the corresponding bit weights:

| Bit | 0 | 1 | 2 | 3 | 4 | 5 | 6 | 7 |
|--------|------------------|------------------|------------------|------------------|------------------|------------------|------------------|------------------|
| Byte 1 | S | C ₆ | C ₅ | C ₄ | C ₃ | C ₂ | C ₁ | C ₀ |
| Byte 2 | Q ₋₁ | Q ₋₂ | Q ₋₃ | Q ₋₄ | Q ₋₅ | Q ₋₆ | Q ₋₇ | Q ₋₈ |
| Byte 3 | Q ₋₉ | Q ₋₁₀ | Q ₋₁₁ | Q ₋₁₂ | Q ₋₁₃ | Q ₋₁₄ | Q ₋₁₅ | Q ₋₁₆ |
| Byte 4 | Q ₋₁₇ | Q ₋₁₈ | Q ₋₁₉ | Q ₋₂₀ | Q ₋₂₁ | Q ₋₂₂ | Q ₋₂₃ | Q ₋₂₄ |

S=sign bit.—(One = negative number).

C=excess 64 hexadecimal exponent.—This is a binary exponent of 16. It has been biased by 64 such that it represents $16^{(CCCCCC-64)}$ where CCCCCC can assume values from 0 to 127.

Q₋₁₋₂₄ magnitude fraction.—This is a 24 bit positive binary fraction (i.e., the number system is sign and magnitude). The radix point is to the left of the most significant bit (*Q*₋₁) with the MSB being defined as 2^{-1} . The sign and fraction can assume values from $(1 - 2^{-24}$ to $-1 + 2^{-24}$). It must always be written as a hexadecimal left justified number. If this fraction is zero, the sign and exponent must also be zero (i.e., the entire word is zero.)

Input signal = $(-1)^S \times 0.QQQQ,QQQQ,QQQQ,QQQQ,QQQQ,QQQQ \times 16^{(CCCCCC-64)} \times \text{DSM}$ millivolts where DSM is the value required to descale the data sample to the recording system input level. DSM is defined in Bytes 17–20 of each channel set descriptor in the scan type header. This data recording method has more than sufficient range to handle the dynamic range of a typical seismic system. Thus, DSM may not be needed to account for any scaling and may be recorded as 1.0.

4 byte IEEE floating point data - recording method

The IEEE (Institute of Electrical and Electronics Engineers) format is fully documented in the IEEE standard, "ANSI/IEEE Std 754 - 1985", available from the IEEE (<http://ieeexplore.ieee.org/servlet/opac?punumber=2355>).

The IEEE format is summarized as follows:

| Bit | 0 | 1 | 2 | 3 | 4 | 5 | 6 | 7 |
|--------|------------------|------------------|------------------|------------------|------------------|------------------|------------------|------------------|
| Byte 1 | S | C ₇ | C ₆ | C ₅ | C ₄ | C ₃ | C ₂ | C ₁ |
| Byte 2 | C ₀ | Q ₋₁ | Q ₋₂ | Q ₋₃ | Q ₋₄ | Q ₋₅ | Q ₋₆ | Q ₋₇ |
| Byte 3 | Q ₋₈ | Q ₋₉ | Q ₋₁₀ | Q ₋₁₁ | Q ₋₁₂ | Q ₋₁₃ | Q ₋₁₄ | Q ₋₁₅ |
| Byte 4 | Q ₋₁₆ | Q ₋₁₇ | Q ₋₁₈ | Q ₋₁₉ | Q ₋₂₀ | Q ₋₂₁ | Q ₋₂₂ | Q ₋₂₃ |

The value (*v*) of a floating-point number represented in this format is determined as follows:

| | |
|--------------------------------------------------------------------------|---------------------------|
| if $e = 255$ & $f \neq 0$. $v = \text{NaN}$ | Not-a-Number (see Note 1) |
| if $e = 255$ & $f = 0$. $v = (-1)^S \times \infty$ | Overflow |
| if $0 < e < 255$ $v = (-1)^S \times 2^{e-127} \times (1.f)$ | Normalized |
| if $e = 0$ & $f \neq 0$. . . $v = (-1)^S \times 2^{e-126} \times (0.f)$ | Denormalized |
| if $e = 0$ & $f = 0$. . . $v = (-1)^S \times 0$ | \pm zero |

where e = binary value of all C's (exponent)
 f = binary value of all Q's (fraction)

NOTE 1. A Not-a-Number (NaN) is interpreted as an invalid number. All other numbers are valid and interpreted as described above.

Input signal = $v \times \text{DSM}$ millivolts where DSM is the value required to descale the data sample to the recording system input level. DSM is defined in Bytes 17–20 of each channel set descriptor in the scan type header. This data recording method has more than sufficient range to handle the dynamic range of a typical seismic system. Thus, DSM may not be needed to account for any scaling and may be recorded as 1.0.

8 byte IEEE floating point data – recording method

The IEEE (Institute of Electrical and Electronics Engineers) format is fully documented in the IEEE standard, "ANSI/IEEE Std 754 - 1985", available from the IEEE (<http://ieeexplore.ieee.org/servlet/opac?punumber=2355>).

The IEEE format is summarized as follows:

| Bit | 0 | 1 | 2 | 3 | 4 | 5 | 6 | 7 |
|--------|------------------|------------------|------------------|------------------|------------------|------------------|------------------|------------------|
| Byte 1 | S | C ₁₁ | C ₁₀ | C ₉ | C ₈ | C ₇ | C ₆ | C ₅ |
| Byte 2 | C ₄ | C ₃ | C ₂ | C ₁ | Q ₋₁ | Q ₋₂ | Q ₋₃ | Q ₋₄ |
| Byte 3 | Q ₋₅ | Q ₋₆ | Q ₋₇ | Q ₋₈ | Q ₋₉ | Q ₋₁₀ | Q ₋₁₁ | Q ₋₁₂ |
| Byte 4 | Q ₋₁₃ | Q ₋₁₄ | Q ₋₁₅ | Q ₋₁₆ | Q ₋₁₇ | Q ₋₁₈ | Q ₋₁₉ | Q ₋₂₀ |
| Byte 5 | Q ₋₂₁ | Q ₋₂₂ | Q ₋₂₃ | Q ₋₂₄ | Q ₋₂₅ | Q ₋₂₆ | Q ₋₂₇ | Q ₋₂₈ |
| Byte 6 | Q ₋₂₉ | Q ₋₃₀ | Q ₋₃₁ | Q ₋₃₂ | Q ₋₃₃ | Q ₋₃₄ | Q ₋₃₅ | Q ₋₃₆ |
| Byte 7 | Q ₋₃₇ | Q ₋₃₈ | Q ₋₃₉ | Q ₋₄₀ | Q ₋₄₁ | Q ₋₄₂ | Q ₋₄₃ | Q ₋₄₄ |
| Byte 8 | Q ₋₄₅ | Q ₋₄₆ | Q ₋₄₇ | Q ₋₄₈ | Q ₋₄₉ | Q ₋₅₀ | Q ₋₅₁ | Q ₋₅₂ |

The value (v) of a floating-point number represented in this format is determined as follows:

| | |
|-----------------------------------------------------------------------------|---------------------------|
| if $e = 2047$ & $f \neq 0$. $v = \text{NaN}$ | Not-a-Number (see Note 1) |
| if $e = 2047$ & $f = 0$. $v = (-1)^s \times \infty$ | Overflow (infinity) |
| if $0 < e < 2047$ $v = (-1)^s \times 2^{e-1023} \times (1.f)$ | Normalized |
| if $e = 0$ & $f \neq 0$ $v = (-1)^s \times 2^{e-1022} \times (0.f)$ | Denormalized |
| if $e = 0$ & $f = 0$ $v = (-1)^s \times 0$ | \pm zero |

where e = binary value of all C's (exponent)
 f = binary value of all Q's (fraction)

NOTE 1. A Not-a-Number (NaN) is interpreted as an invalid number. All other numbers are valid and interpreted as described above.

Input signal = $v \times \text{DSM}$ millivolts where DSM is the value required to descale the data sample to the recording system input level. DSM is defined in Bytes 17–20 of each channel set descriptor in the scan type header. This data recording method has more than sufficient range to handle the dynamic range of a typical seismic system. Thus, DSM may not be needed to account for any scaling and may be recorded as 1.0.

Integer formats:

24 bit two's complement format:

| Bit | 0 | 1 | 2 | 3 | 4 | 5 | 6 | 7 |
|--------|-----------------|-----------------|-----------------|-----------------|-----------------|-----------------|-----------------|-----------------|
| Byte 1 | I ₂₃ | I ₂₂ | I ₂₁ | I ₂₀ | I ₁₉ | I ₁₈ | I ₁₇ | I ₁₆ |

| | | | | | | | | |
|--------|-----------------|-----------------|-----------------|-----------------|-----------------|-----------------|----------------|----------------|
| Byte 2 | I ₁₅ | I ₁₄ | I ₁₃ | I ₁₂ | I ₁₁ | I ₁₀ | I ₉ | I ₈ |
| Byte 3 | I ₇ | I ₆ | I ₅ | I ₄ | I ₃ | I ₂ | I ₁ | I ₀ |

$Input\ signal = \{ (I_{15}, I_{14}, I_{13}, I_{12}, I_{11}, I_{10}, I_{9}, I_{8} + 2^{23}) \bmod 2^{24} - 2^{23} \} \times DSM$ millivolts where DSM is the value required to descale the data sample to the recording system input level. DSM is defined in Bytes 17–20 of each channel set descriptor in the scan type header.

32 bit two’s complement format:

| | | | | | | | | |
|--------|-----------------|-----------------|-----------------|-----------------|-----------------|-----------------|-----------------|-----------------|
| Bit | 0 | 1 | 2 | 3 | 4 | 5 | 6 | 7 |
| Byte 1 | I ₃₁ | I ₃₀ | I ₂₉ | I ₂₈ | I ₂₇ | I ₂₆ | I ₂₅ | I ₂₄ |
| Byte 2 | I ₂₃ | I ₂₂ | I ₂₁ | I ₂₀ | I ₁₉ | I ₁₈ | I ₁₇ | I ₁₆ |
| Byte 3 | I ₁₅ | I ₁₄ | I ₁₃ | I ₁₂ | I ₁₁ | I ₁₀ | I ₉ | I ₈ |
| Byte 4 | I ₇ | I ₆ | I ₅ | I ₄ | I ₃ | I ₂ | I ₁ | I ₀ |

$Input\ signal = \{ (I_{31}, I_{30}, I_{29}, I_{28}, I_{27}, I_{26}, I_{25}, I_{24} + 2^{31}) \bmod 2^{32} - 2^{31} \} \times DSM$ millivolts where DSM is the value required to descale the data sample to the recording system input level. DSM is defined in Bytes 17–20 of each channel set descriptor in the scan type header.

6.2 DSM Factor calculation and physical unit

The Descale multiplier (DSM) parameter is provided to allow the dimensionless numbers recorded on tape to be “descaled” back to the instantaneous sample values in millivolts at the system inputs^{*)}. As of Rev 3, DSM is stored in bytes 17–20 of the Channel Set Descriptor in the Scan Type Header as a 4 byte IEEE floating point number. Prior to that it was computed from an MP exponent stored in byte 8 of the Channel Set Descriptor.

In general, recording systems scale the input signal level in order to match the useful range of input levels to the gain-ranging amplifier. DSM must account for all scaling in the acquisition system. However, in some high resolution formats like the 4 byte hexadecimal, or 4 or 8 byte IEEE floating point cases, the data recording method may have sufficient range, and the DSM may be set to 1.0.

**) In several instances “sample values in millivolt at system inputs” may be unclear. Modern acquisition systems often perform several stages of digital processing before the data samples are stored, and in many cases, especially for auxiliary data, millivolt samples may not even be applicable at all. In these situations the recorder should follow the general advice above, and just make sure the dynamic range of the sample values matches the useful range of the input levels. In addition it is also highly recommended to store sensor sensitivity (in a Sensor Info Header extension block as part of the Trace Header), to ensure the sample value can be converted to a physical unit.*

Physical unit conversion

To be able to relate the seismic traces to external events it may be needed to convert the millivolt values in the traces to the physical unit. The physical unit of the traces is listed in byte 62 of the Channel Set Descriptor. This is repeated in byte 31 of Trace Header Extension block. The sensor sensitivity (Sensor Info Header Extension bytes 9–12, 4 byte IEEE float) is multiplied with the millivolt sample value to calculate the physical unit number.

The following equation converts a trace sample value to a physical unit sample value

$$V_p = V_t * DSM * SS$$

V_p - Physical sample value

V_t - Trace sample value

DSM - Multiplication factor to convert to millivolt value

SS - Sensor sensitivity

The type of the physical unit are listed in the table found Chapter 8, Trace Header Extension, byte 31 definition. Typical types are millibar (e.g. hydrophone data), millimeters/second (e.g. geophone data) or meters (e.g. depth measurement).

DSM may be written

$$DSM = 2^{MP}$$

The calculation of MP for a data recording method is given by one of the following equations:

For floating point data:

- | | |
|---------------------------------------------|------------------------------------------------------------------------|
| 1. $MP = FS - PA - C_{max}$ | For binary exponents. |
| 2. $MP = FS - PA - 2 \times C_{max}$ | For quaternary exponents. |
| 3. $MP = FS - PA - 4 \times C_{max}$ | For hexadecimal exponents (except for the four byte excess 64 method). |
| 4. $MP = FS - PA - 4 \times (C_{max} - 64)$ | For excess 64 hexadecimal exponents. |
| 5. $MP = FS - PA - (C_{max} - 127)$ | For 32 bit IEEE exponents. |
| 6. $MP = FS - PA - (C_{max} - 1023)$ | For 64 bit IEEE exponents. |

Where:

2^{FS} = Converter full scale (millivolts),

2^{PA} = Minimum system gain,

C_{max} = maximum value of the data exponent;

$C_{max} =$

- 15 for binary exponents
- 7 for quaternary exponents,
- 3 for hexadecimal exponents, except excess 64,
- 127 for excess 64 exponents and the output of the analog-to-digital converter is written as the fractional portion of the data value.
- 255 for 32 bit IEEE exponents and the output of the analog-to-digital converter is written as the fractional portion of the data value.
- 2047 for 64 bit IEEE exponents and the output of the analog-to-digital converter is written as the fractional portion of the data value.

For integer data:

1. $MP = FS - PA - IS;$

Where:

2^{FS} = Converter full scale (millivolts),

2^{PA} = Minimum system gain,

$2^{IS}-1$ = Integer number system positive full scale, and

the output of the analog-to-digital converter is written as an integer.

The term “minimum system gain” includes preamplifier gain and the minimum floating point amplifier gain. For example, one system may use a preamplifier gain of 256 and a minimum floating point amplifier gain of one. The minimum system gain is $256 \times 1 = 2^8$, so PA = 8. Another system may use a preamplifier gain of 320 and a minimum floating point amplifier gain of 0.8. In this case, the minimum system gain is $320 \times 0.8 = 256$ or 2^8 . Again PA = 8.

PA may also account for any amplification needed to accommodate an analog to digital converter with a full scale value that is not a power of 2 in millivolts. For example, a 10 V (10,000 mV) converter may be preceded by an amplifier with a gain of 1.221 (10,000/8,192). This gain may be accounted for in PA. Alternatively, it could be considered part of the converter, making it appear to have a binary full scale.

Justifications for the Equations

The output of the analog-to-digital converter is written as the fractional portion of the data value. This is equivalent to dividing the value by the full scale of the converter. In order to compensate for this, the data value recorded on tape must be multiplied by the full scale value of the converter (2^{FS}). Thus FS appears in equations (1)–(4) with a positive sign.

The input signal was multiplied by the minimum system gain (2^{PA}) which, as mentioned, includes any preamplifier gain, minimum floating point amplifier gain, or analog-to-digital converter adjustment gain. The data recorded on tape must be divided by this minimum system gain; thus, PA appears in the equations with a negative sign.

Large input signals converted at minimum floating point amplifier gain are written on tape with the maximum exponent for the data recording method used. Likewise, small signals converted at full gain are written with the maximum exponent. The data as written have been multiplied by the exponent base raised to C_{max} (minus 64, 127, or 1023 as appropriate to the number format.) Thus C_{max} appears in the equations with a negative sign. MP is a power of 2 so the quaternary and hexadecimal C_{max} values are multiplied by 2 and 4, respectively ($4^c = 2^{2c}$ and $16^c = 2^{4c}$).

Data processing done prior to data storage.

In modern recording systems significant data processing is commonly done prior to storing the data on tape. The DSM factor may have to be adapted to make sure the number resolution is maintained in the trace data, i.e. the processing scaling parameters must be incorporated in the DSM factor.

6.3 Sensor calibration

Trace Header frequency domain calibration

SEGD supports storing individual sensor calibration values in Trace Header Extension blocks (see Sensor Calibration Header)”. Each 32 byte Sensor Calibration Header block contains two frequency/amplitude/phase groups, and multiple blocks may be used to define the complete frequency domain calibration function for the sensor. Sensor Calibration Header block allows a maximum of about 500 frequencies per trace, assuming no other meta-information exist in the trace header

The calibration corrected sensor value is achieved by converting the time series trace value to frequency domain, and multiplying with the calibration function

$$V_{\text{calibrated}} = F_c \cdot V_{\text{trace}}$$

Where

$V_{\text{calibrated}}$ = Calibration corrected trace signal (in frequency domain)

F_c = Sensor calibration transfer function as described by the values in the sensor calibration header.

V_{trace} = The uncorrected trace value (in frequency domain)

The sensor calibration values in addition to the individual Sensor Sensitivity values can be used to correct for most sensor variations needed to achieve a high fidelity signal needed in modern seismic acquisition systems.

Calibration Channel – time domain

A Calibration Channel Set can be used if time series calibration is preferred. The Calibration Channel Set also allows a more high fidelity calibration compared to the Trace Header Extension blocks. The frequency and length of the calibration channel may be adjusted to achieve the accuracy required. Calibration Channel Sets has Channel type set to $F0_{16}$ in Channel Set Descriptor byte 4. The Calibration Channel is a time series signal that can be correlated with the trace value to achieve a calibrated trace signal. By converting both the trace and calibration trace time series to frequency domain, the formula shown above can be used. The indices in the Trace Header Extension block determine which trace the calibration trace applies to.

7.0 Header Tables

Note:

Several blocks contain undefined fields, indicated by X in the tables. These values are undefined by the format, and may be used by the manufacturer to store manufacturer defined information. However, *be aware that the fields may be used in future versions of the format*, and the manufacturer use these fields at own risk. It is recommended to record '0' in fields indicated by X, and store all manufacturer defined information in user defined header blocks (External or Extended header, General Trailer blocks, or General Header/Trace Header blocks with ID B0₁₆ through FF₁₆). These will more likely to be compliant with future versions of the format.

7.1 GENERAL HEADER BLOCK #1

| Bit No. | 0 | 1 | 2 | 3 | 4 | 5 | 6 | 7 | |
|------------------------------|-------------------|-------------------|-------------------|-------------------|-------------------|-------------------|-------------------|-------------------|-----|
| BCD Value MSD | 8 | 4 | 2 | 1 | 8 | 4 | 2 | 1 | LSD |
| Binary Value MSB | 128 | 64 | 32 | 16 | 8 | 4 | 2 | 1 | LSB |
| File Number | F ₁ | F ₁ | F ₁ | F ₁ | F ₂ | F ₂ | F ₂ | F ₂ | 1 |
| | F ₃ | F ₃ | F ₃ | F ₃ | F ₄ | F ₄ | F ₄ | F ₄ | 2 |
| Format Code | Y ₁ | Y ₁ | Y ₁ | Y ₁ | Y ₂ | Y ₂ | Y ₂ | Y ₂ | 3 |
| | Y ₃ | Y ₃ | Y ₃ | Y ₃ | Y ₄ | Y ₄ | Y ₄ | Y ₄ | 4 |
| General Constants | K ₁ | K ₁ | K ₁ | K ₁ | K ₂ | K ₂ | K ₂ | K ₂ | 5 |
| | K ₃ | K ₃ | K ₃ | K ₃ | K ₄ | K ₄ | K | K ₄ | 6 |
| | K ₅ | K ₅ | K ₅ | K ₅ | K ₆ | K ₆ | K ₆ | K ₆ | 7 |
| | K ₇ | K ₇ | K ₇ | K ₇ | K ₈ | K ₈ | K ₈ | K ₈ | 8 |
| | K ₉ | K ₉ | K ₉ | K ₉ | K ₁₀ | K ₁₀ | K ₁₀ | K ₁₀ | 9 |
| | K ₁₁ | K ₁₁ | K ₁₁ | K ₁₁ | K ₁₂ | K ₁₂ | K ₁₂ | K ₁₂ | 10 |
| Year | YR ₁ | YR ₁ | YR ₁ | YR ₁ | YR ₂ | YR ₂ | YR ₂ | YR ₂ | 11 |
| # Additional Blks in Gen Hdr | GH ₃ | GH ₂ | GH ₁ | GH ₀ | DY ₁ | DY ₁ | DY ₁ | DY ₁ | 12 |
| Day (DY) | DY ₂ | DY ₂ | DY ₂ | DY ₂ | DY ₃ | DY ₃ | DY ₃ | DY ₃ | 13 |
| Hour | H ₁ | H ₁ | H ₁ | H ₁ | H ₂ | H ₂ | H ₂ | H ₂ | 14 |
| Minute | MI ₁ | MI ₁ | MI ₁ | MI ₁ | MI ₂ | MI ₂ | MI ₂ | MI ₂ | 15 |
| Second | SE ₁ | SE ₁ | SE ₁ | SE ₁ | SE ₂ | SE ₂ | SE ₂ | SE ₂ | 16 |
| Manufacture's Code | M ₁ | M ₁ | M ₁ | M ₁ | M ₂ | M ₂ | M ₂ | M ₂ | 17 |
| | M ₃ | M ₃ | M ₃ | M ₃ | M ₄ | M ₄ | M ₄ | M ₄ | 18 |
| | M ₅ | M ₅ | M ₅ | M ₅ | M ₆ | M ₆ | M ₆ | M ₆ | 19 |
| | 0 | 0 | 0 | 0 | 0 | 0 | 0 | 0 | 20 |
| | 0 | 0 | 0 | 0 | 0 | 0 | 0 | 0 | 21 |
| | 0 | 0 | 0 | 0 | 0 | 0 | 0 | 0 | 22 |
| Base Scan Interval | I ₃ | I ₂ | I ₁ | I ₀ | L ₁ | L ₂ | L ₃ | L ₄ | 23 |
| Polarity (P) | P | P | P | P | 0 | 0 | 0 | 0 | 24 |
| | 0 | 0 | 0 | 0 | 0 | 0 | 0 | 0 | 25 |
| Record Type (Z) | Z | Z | Z | Z | R ₁ | R ₁ | R ₁ | R ₁ | 26 |
| Record Length (R) | R ₂ | R ₂ | R ₂ | R ₂ | R ₃ | R ₃ | R ₃ | R ₃ | 27 |
| Scan Types/Record | ST/R ₁ | ST/R ₁ | ST/R ₁ | ST/R ₁ | ST/R ₂ | ST/R ₂ | ST/R ₂ | ST/R ₂ | 28 |
| Chan Sets/Scan Type | CS ₁ | CS ₁ | CS ₁ | CS ₁ | CS ₂ | CS ₂ | CS ₂ | CS ₂ | 29 |
| Skew Blocks | SK ₁ | SK ₁ | SK ₁ | SK ₁ | SK ₂ | SK ₂ | SK ₂ | SK ₂ | 30 |
| Extended Header Blk | EC ₁ | EC ₁ | EC ₁ | EC ₁ | EC ₂ | EC ₂ | EC ₂ | EC ₂ | 31 |
| External Header Blk | EX ₁ | EX ₁ | EX ₁ | EX ₁ | EX ₂ | EX ₂ | EX ₂ | EX ₂ | 32 |

7.2 GENERAL HEADER BLOCK #2

| Bit No. | 0 | 1 | 2 | 3 | 4 | 5 | 6 | 7 | |
|-------------------------------------------|-------------------|-------------------|-------------------|-------------------|-------------------|-------------------|-------------------|-------------------|-----|
| BCD Value MSD | 8 | 4 | 2 | 1 | 8 | 4 | 2 | 1 | LSD |
| Binary Value MSB | 128 | 64 | 32 | 16 | 8 | 4 | 2 | 1 | LSB |
| Expanded File Number | EF ₂₃ | EF ₂₂ | EF ₂₁ | EF ₂₀ | EF ₁₉ | EF ₁₈ | EF ₁₇ | EF ₁₆ | 1 |
| | EF ₁₅ | EF ₁₄ | EF ₁₃ | EF ₁₂ | EF ₁₁ | EF ₁₀ | EF ₉ | EF ₈ | 2 |
| | EF ₇ | EF ₆ | EF ₅ | EF ₄ | EF ₃ | EF ₂ | EF ₁ | EF ₀ | 3 |
| Extended Channel Sets/ Scan Type | EN ₁₅ | EN ₁₄ | EN ₁₃ | EN ₁₂ | EN ₁₁ | EN ₁₀ | EN ₉ | EN ₈ | 4 |
| | EN ₇ | EN ₆ | EN ₅ | EN ₄ | EN ₃ | EN ₂ | EN ₁ | EN ₀ | 5 |
| Extended Header Blks | ECX ₂₃ | ECX ₂₂ | ECX ₂₁ | ECX ₂₀ | ECX ₁₉ | ECX ₁₈ | ECX ₁₇ | ECX ₁₆ | 6 |
| | ECX ₁₅ | ECX ₁₄ | ECX ₁₃ | ECX ₁₂ | ECX ₁₁ | ECX ₁₀ | ECX ₉ | ECX ₈ | 7 |
| | ECX ₇ | ECX ₆ | ECX ₅ | ECX ₄ | ECX ₃ | ECX ₂ | ECX ₁ | ECX ₀ | 8 |
| Extended Skew blks | ESK ₁₅ | ESK ₁₄ | ESK ₁₃ | ESK ₁₂ | ESK ₁₁ | ESK ₁₀ | ESK ₉ | ESK ₈ | 9 |
| | ESK ₇ | ESK ₆ | ESK ₅ | ESK ₄ | ESK ₃ | ESK ₂ | ESK ₁ | ESK ₀ | 10 |
| SEG-D Revision No. “major” and “minor” | RMJ ₇ | RMJ ₆ | RMJ ₅ | RMJ ₄ | RMJ ₃ | RMJ ₂ | RMJ ₁ | RMJ ₀ | 11 |
| | RMN ₇ | RMN ₆ | RMN ₅ | RMN ₄ | RMN ₃ | RMN ₂ | RMN ₁ | RMN ₀ | 12 |
| General Trailer, Number of Blks | GT ₃₁ | GT ₃₀ | GT ₂₉ | GT ₂₈ | GT ₂₇ | GT ₂₆ | GT ₂₅ | GT ₂₄ | 13 |
| | GT ₂₃ | GT ₂₂ | GT ₂₁ | GT ₂₀ | GT ₁₉ | GT ₁₈ | GT ₁₇ | GT ₁₆ | 14 |
| | GT ₁₅ | GT ₁₄ | GT ₁₃ | GT ₁₂ | GT ₁₁ | GT ₁₀ | GT ₉ | GT ₈ | 15 |
| | GT ₇ | GT ₆ | GT ₅ | GT ₄ | GT ₃ | GT ₂ | GT ₁ | GT ₀ | 16 |
| Extended Record Length | ERL ₃₁ | ERL ₃₀ | ERL ₂₉ | ERL ₂₈ | ERL ₂₇ | ERL ₂₆ | ERL ₂₅ | ERL ₂₄ | 17 |
| | ERL ₂₃ | ERL ₂₂ | ERL ₂₁ | ERL ₂₀ | ERL ₁₉ | ERL ₁₈ | ERL ₁₇ | ERL ₁₆ | 18 |
| | ERL ₁₅ | ERL ₁₄ | ERL ₁₃ | ERL ₁₂ | ERL ₁₁ | ERL ₁₀ | ERL ₉ | ERL ₈ | 19 |
| | ERL ₇ | ERL ₆ | ERL ₅ | ERL ₄ | ERL ₃ | ERL ₂ | ERL ₁ | ERL ₀ | 20 |
| Record Set Number | SN ₁₅ | SN ₁₄ | SN ₁₃ | SN ₁₂ | SN ₁₁ | SN ₁₀ | SN ₉ | SN ₈ | 21 |
| | SN ₇ | SN ₆ | SN ₅ | SN ₄ | SN ₃ | SN ₂ | SN ₁ | SN ₀ | 22 |
| Extended # Additional Blks in Gen Hdr | EGH ₁₅ | EGH ₁₄ | EGH ₁₃ | EGH ₁₂ | EGH ₁₁ | EGH ₁₀ | EGH ₉ | EGH ₈ | 23 |
| | EGH ₇ | EGH ₆ | EGH ₅ | EGH ₄ | EGH ₃ | EGH ₂ | EGH ₁ | EGH ₀ | 24 |
| Dominant Sampling Interval | BSI ₂₃ | BSI ₂₂ | BSI ₂₁ | BSI ₂₀ | BSI ₁₉ | BSI ₁₈ | BSI ₁₇ | BSI ₁₆ | 25 |
| | BSI ₁₅ | BSI ₁₄ | BSI ₁₃ | BSI ₁₂ | BSI ₁₁ | BSI ₁₀ | BSI ₉ | BSI ₈ | 26 |
| | BSI ₇ | BSI ₆ | BSI ₅ | BSI ₄ | BSI ₃ | BSI ₂ | BSI ₁ | BSI ₀ | 27 |
| External Header Blks | EH ₂₃ | EH ₂₂ | EH ₂₁ | EH ₂₀ | EH ₁₉ | EH ₁₈ | EH ₁₇ | EH ₁₆ | 28 |
| | EH ₁₅ | EH ₁₄ | EH ₁₃ | EH ₁₂ | EH ₁₁ | EH ₁₀ | EH ₉ | EH ₈ | 29 |
| | EH ₇ | EH ₆ | EH ₅ | EH ₄ | EH ₃ | EH ₂ | EH ₁ | EH ₀ | 30 |
| | X | X | X | X | X | X | X | X | 31 |
| Header Block Type | 0 | 0 | 0 | 0 | 0 | 0 | 1 | 0 | 32 |

7.3 GENERAL HEADER BLOCK #3 (Timestamp and size header)

| | | | | | | | | | |
|-------------------|------------------|------------------|------------------|------------------|------------------|------------------|------------------|------------------|-----|
| Bit No. | 0 | 1 | 2 | 3 | 4 | 5 | 6 | 7 | |
| BCD Value MSD | 8 | 4 | 2 | 1 | 8 | 4 | 2 | 1 | LSD |
| Binary Value MSB | 128 | 64 | 32 | 16 | 8 | 4 | 2 | 1 | LSB |
| Time Zero | TZ ₆₃ | TZ ₆₂ | TZ ₆₁ | TZ ₆₀ | TZ ₅₉ | TZ ₅₈ | TZ ₅₇ | TZ ₅₆ | 1 |
| | TZ ₅₅ | TZ ₅₄ | TZ ₅₃ | TZ ₅₂ | TZ ₅₁ | TZ ₅₀ | TZ ₄₉ | TZ ₄₈ | 2 |
| | TZ ₄₇ | TZ ₄₆ | TZ ₄₅ | TZ ₄₄ | TZ ₄₃ | TZ ₄₂ | TZ ₄₁ | TZ ₄₀ | 3 |
| | TZ ₃₉ | TZ ₃₈ | TZ ₃₇ | TZ ₃₆ | TZ ₃₅ | TZ ₃₄ | TZ ₃₃ | TZ ₃₂ | 4 |
| | TZ ₃₁ | TZ ₃₀ | TZ ₂₉ | TZ ₂₈ | TZ ₂₇ | TZ ₂₆ | TZ ₂₅ | TZ ₂₄ | 5 |
| | TZ ₂₃ | TZ ₂₂ | TZ ₂₁ | TZ ₂₀ | TZ ₁₉ | TZ ₁₈ | TZ ₁₇ | TZ ₁₆ | 6 |
| | TZ ₁₅ | TZ ₁₄ | TZ ₁₃ | TZ ₁₂ | TZ ₁₁ | TZ ₁₀ | TZ ₉ | TZ ₈ | 7 |
| | TZ ₇ | TZ ₆ | TZ ₅ | TZ ₄ | TZ ₃ | TZ ₂ | TZ ₁ | TZ ₀ | 8 |
| Record Size | RS ₆₃ | RS ₆₂ | RS ₆₁ | RS ₆₀ | RS ₅₉ | RS ₅₈ | RS ₅₇ | RS ₅₆ | 9 |
| | RS ₅₅ | RS ₅₄ | RS ₅₃ | RS ₅₂ | RS ₅₁ | RS ₅₀ | RS ₄₉ | RS ₄₈ | 10 |
| | RS ₄₇ | RS ₄₆ | RS ₄₅ | RS ₄₄ | RS ₄₃ | RS ₄₂ | RS ₄₁ | RS ₄₀ | 11 |
| | RS ₃₉ | RS ₃₈ | RS ₃₇ | RS ₃₆ | RS ₃₅ | RS ₃₄ | RS ₃₃ | RS ₃₂ | 12 |
| | RS ₃₁ | RS ₃₀ | RS ₂₉ | RS ₂₈ | RS ₂₇ | RS ₂₆ | RS ₂₅ | RS ₂₄ | 13 |
| | RS ₂₃ | RS ₂₂ | RS ₂₁ | RS ₂₀ | RS ₁₉ | RS ₁₈ | RS ₁₇ | RS ₁₆ | 14 |
| | RS ₁₅ | RS ₁₄ | RS ₁₃ | RS ₁₂ | RS ₁₁ | RS ₁₀ | RS ₉ | RS ₈ | 15 |
| | RS ₇ | RS ₆ | RS ₅ | RS ₄ | RS ₃ | RS ₂ | RS ₁ | RS ₀ | 16 |
| Data Size | DS ₆₃ | DS ₆₂ | DS ₆₁ | DS ₆₀ | DS ₅₉ | DS ₅₈ | DS ₅₇ | DS ₅₆ | 17 |
| | DS ₅₅ | DS ₅₄ | DS ₅₃ | DS ₅₂ | DS ₅₁ | DS ₅₀ | DS ₄₉ | DS ₄₈ | 18 |
| | DS ₄₇ | DS ₄₆ | DS ₄₅ | DS ₄₄ | DS ₄₃ | DS ₄₂ | DS ₄₁ | DS ₄₀ | 19 |
| | DS ₃₉ | DS ₃₈ | DS ₃₇ | DS ₃₆ | DS ₃₅ | DS ₃₄ | DS ₃₃ | DS ₃₂ | 20 |
| | DS ₃₁ | DS ₃₀ | DS ₂₉ | DS ₂₈ | DS ₂₇ | DS ₂₆ | DS ₂₅ | DS ₂₄ | 21 |
| | DS ₂₃ | DS ₂₂ | DS ₂₁ | DS ₂₀ | DS ₁₉ | DS ₁₈ | DS ₁₇ | DS ₁₆ | 22 |
| | DS ₁₅ | DS ₁₄ | DS ₁₃ | DS ₁₂ | DS ₁₁ | DS ₁₀ | DS ₉ | DS ₈ | 23 |
| | DS ₇ | DS ₆ | DS ₅ | DS ₄ | DS ₃ | DS ₂ | DS ₁ | DS ₀ | 24 |
| Header Size | HS ₃₁ | HS ₃₀ | HS ₂₉ | HS ₂₈ | HS ₂₇ | HS ₂₆ | HS ₂₅ | HS ₂₄ | 25 |
| | HS ₂₃ | HS ₂₂ | HS ₂₁ | HS ₂₀ | HS ₁₉ | HS ₁₈ | HS ₁₇ | HS ₁₆ | 26 |
| | HS ₁₅ | HS ₁₄ | HS ₁₃ | HS ₁₂ | HS ₁₁ | HS ₁₀ | HS ₉ | HS ₈ | 27 |
| | HS ₇ | HS ₆ | HS ₅ | HS ₄ | HS ₃ | HS ₂ | HS ₁ | HS ₀ | 28 |
| Extd Rec Mode | ERM ₇ | ERM ₆ | ERM ₅ | ERM ₄ | ERM ₃ | ERM ₂ | ERM ₁ | ERM ₀ | 29 |
| Rel Time Mode | RTM ₇ | RTM ₆ | RTM ₅ | RTM ₄ | RTM ₃ | RTM ₂ | RTM ₁ | RTM ₀ | 30 |
| | X | X | X | X | X | X | X | X | 31 |
| Header Block Type | 0 | 0 | 0 | 0 | 0 | 0 | 1 | 1 | 32 |

7.4 GENERAL HEADER BLOCK #4 (Vessel/Crew Identification) (optional)

| | | | | | | | | | |
|--------------------------|-----|-----|-----|-----|-----|-----|-----|-----|-----|
| Bit No. | 0 | 1 | 2 | 3 | 4 | 5 | 6 | 7 | |
| BCD Value MSD | 8 | 4 | 2 | 1 | 8 | 4 | 2 | 1 | LSD |
| Binary Value MSB | 128 | 64 | 32 | 16 | 8 | 4 | 2 | 1 | LSB |
| Abbr Vessel or Crew Name | VCA | VCA | VCA | VCA | VCA | VCA | VCA | VCA | 1 |
| | VCA | VCA | VCA | VCA | VCA | VCA | VCA | VCA | 2 |
| | VCA | VCA | VCA | VCA | VCA | VCA | VCA | VCA | 3 |
| Vessel or Crew Name | VC | VC | VC | VC | VC | VC | VC | VC | 4 |
| | VC | VC | VC | VC | VC | VC | VC | VC | 5 |

| | | | | | | | | | |
|-------------------|----|----|----|----|----|----|----|----|----|
| | VC | VC | VC | VC | VC | VC | VC | VC | 6 |
| | VC | VC | VC | VC | VC | VC | VC | VC | 7 |
| | VC | VC | VC | VC | VC | VC | VC | VC | 8 |
| | VC | VC | VC | VC | VC | VC | VC | VC | 9 |
| | VC | VC | VC | VC | VC | VC | VC | VC | 10 |
| | VC | VC | VC | VC | VC | VC | VC | VC | 11 |
| | VC | VC | VC | VC | VC | VC | VC | VC | 12 |
| | VC | VC | VC | VC | VC | VC | VC | VC | 13 |
| | VC | VC | VC | VC | VC | VC | VC | VC | 14 |
| | VC | VC | VC | VC | VC | VC | VC | VC | 15 |
| | VC | VC | VC | VC | VC | VC | VC | VC | 16 |
| | VC | VC | VC | VC | VC | VC | VC | VC | 17 |
| | VC | VC | VC | VC | VC | VC | VC | VC | 18 |
| | VC | VC | VC | VC | VC | VC | VC | VC | 19 |
| | VC | VC | VC | VC | VC | VC | VC | VC | 20 |
| | VC | VC | VC | VC | VC | VC | VC | VC | 21 |
| | VC | VC | VC | VC | VC | VC | VC | VC | 22 |
| | VC | VC | VC | VC | VC | VC | VC | VC | 23 |
| | VC | VC | VC | VC | VC | VC | VC | VC | 24 |
| | VC | VC | VC | VC | VC | VC | VC | VC | 25 |
| | VC | VC | VC | VC | VC | VC | VC | VC | 26 |
| | VC | VC | VC | VC | VC | VC | VC | VC | 27 |
| | VC | VC | VC | VC | VC | VC | VC | VC | 28 |
| | VC | VC | VC | VC | VC | VC | VC | VC | 29 |
| | VC | VC | VC | VC | VC | VC | VC | VC | 30 |
| | VC | VC | VC | VC | VC | VC | VC | VC | 31 |
| Header Block Type | 0 | 0 | 0 | 1 | 0 | 0 | 0 | 0 | 32 |

7.5 GENERAL HEADER BLOCK #5 (Survey Area Name) (optional)

| | | | | | | | | | |
|------------------|-----|-----|-----|-----|-----|-----|-----|-----|-----|
| Bit No. | 0 | 1 | 2 | 3 | 4 | 5 | 6 | 7 | |
| BCD Value MSD | 8 | 4 | 2 | 1 | 8 | 4 | 2 | 1 | LSD |
| Binary Value MSB | 128 | 64 | 32 | 16 | 8 | 4 | 2 | 1 | LSB |
| Survey Area Name | SAN | SAN | SAN | SAN | SAN | SAN | SAN | SAN | 1 |
| | SAN | SAN | SAN | SAN | SAN | SAN | SAN | SAN | 2 |
| | SAN | SAN | SAN | SAN | SAN | SAN | SAN | SAN | 3 |
| | SAN | SAN | SAN | SAN | SAN | SAN | SAN | SAN | 4 |
| | SAN | SAN | SAN | SAN | SAN | SAN | SAN | SAN | 5 |
| | SAN | SAN | SAN | SAN | SAN | SAN | SAN | SAN | 6 |
| | SAN | SAN | SAN | SAN | SAN | SAN | SAN | SAN | 7 |
| | SAN | SAN | SAN | SAN | SAN | SAN | SAN | SAN | 8 |
| | SAN | SAN | SAN | SAN | SAN | SAN | SAN | SAN | 9 |
| | SAN | SAN | SAN | SAN | SAN | SAN | SAN | SAN | 10 |
| | SAN | SAN | SAN | SAN | SAN | SAN | SAN | SAN | 11 |
| | SAN | SAN | SAN | SAN | SAN | SAN | SAN | SAN | 12 |
| | SAN | SAN | SAN | SAN | SAN | SAN | SAN | SAN | 13 |
| | SAN | SAN | SAN | SAN | SAN | SAN | SAN | SAN | 14 |
| | SAN | SAN | SAN | SAN | SAN | SAN | SAN | SAN | 15 |

| | | | | | | | | | |
|-------------------|-----|-----|-----|-----|-----|-----|-----|-----|----|
| | SAN | SAN | SAN | SAN | SAN | SAN | SAN | SAN | 16 |
| | SAN | SAN | SAN | SAN | SAN | SAN | SAN | SAN | 17 |
| | SAN | SAN | SAN | SAN | SAN | SAN | SAN | SAN | 18 |
| | SAN | SAN | SAN | SAN | SAN | SAN | SAN | SAN | 19 |
| | SAN | SAN | SAN | SAN | SAN | SAN | SAN | SAN | 20 |
| | SAN | SAN | SAN | SAN | SAN | SAN | SAN | SAN | 21 |
| | SAN | SAN | SAN | SAN | SAN | SAN | SAN | SAN | 22 |
| | SAN | SAN | SAN | SAN | SAN | SAN | SAN | SAN | 23 |
| | SAN | SAN | SAN | SAN | SAN | SAN | SAN | SAN | 24 |
| | SAN | SAN | SAN | SAN | SAN | SAN | SAN | SAN | 25 |
| | SAN | SAN | SAN | SAN | SAN | SAN | SAN | SAN | 26 |
| | SAN | SAN | SAN | SAN | SAN | SAN | SAN | SAN | 27 |
| | SAN | SAN | SAN | SAN | SAN | SAN | SAN | SAN | 28 |
| | SAN | SAN | SAN | SAN | SAN | SAN | SAN | SAN | 29 |
| | SAN | SAN | SAN | SAN | SAN | SAN | SAN | SAN | 30 |
| | SAN | SAN | SAN | SAN | SAN | SAN | SAN | SAN | 31 |
| Header Block Type | 0 | 0 | 0 | 1 | 0 | 0 | 0 | 1 | 32 |

7.6 GENERAL HEADER BLOCK #6 (Client Identification) (optional)

| | | | | | | | | | |
|-----------------------|-----|----|----|----|----|----|----|----|-----|
| Bit No. | 0 | 1 | 2 | 3 | 4 | 5 | 6 | 7 | |
| BCD Value MSD | 8 | 4 | 2 | 1 | 8 | 4 | 2 | 1 | LSD |
| Binary Value MSB | 128 | 64 | 32 | 16 | 8 | 4 | 2 | 1 | LSB |
| Client Identification | CI | CI | CI | CI | CI | CI | CI | CI | 1 |
| | CI | CI | CI | CI | CI | CI | CI | CI | 2 |
| | CI | CI | CI | CI | CI | CI | CI | CI | 3 |
| | CI | CI | CI | CI | CI | CI | CI | CI | 4 |
| | CI | CI | CI | CI | CI | CI | CI | CI | 5 |
| | CI | CI | CI | CI | CI | CI | CI | CI | 6 |
| | CI | CI | CI | CI | CI | CI | CI | CI | 7 |
| | CI | CI | CI | CI | CI | CI | CI | CI | 8 |
| | CI | CI | CI | CI | CI | CI | CI | CI | 9 |
| | CI | CI | CI | CI | CI | CI | CI | CI | 10 |
| | CI | CI | CI | CI | CI | CI | CI | CI | 11 |
| | CI | CI | CI | CI | CI | CI | CI | CI | 12 |
| | CI | CI | CI | CI | CI | CI | CI | CI | 13 |
| | CI | CI | CI | CI | CI | CI | CI | CI | 14 |
| | CI | CI | CI | CI | CI | CI | CI | CI | 15 |
| | CI | CI | CI | CI | CI | CI | CI | CI | 16 |
| | CI | CI | CI | CI | CI | CI | CI | CI | 17 |
| | CI | CI | CI | CI | CI | CI | CI | CI | 18 |
| | CI | CI | CI | CI | CI | CI | CI | CI | 19 |
| | CI | CI | CI | CI | CI | CI | CI | CI | 20 |
| | CI | CI | CI | CI | CI | CI | CI | CI | 21 |
| | CI | CI | CI | CI | CI | CI | CI | CI | 22 |
| | CI | CI | CI | CI | CI | CI | CI | CI | 23 |
| | CI | CI | CI | CI | CI | CI | CI | CI | 24 |
| | CI | CI | CI | CI | CI | CI | CI | CI | 25 |

| | | | | | | | | | |
|-------------------|----|----|----|----|----|----|----|----|----|
| | CI | CI | CI | CI | CI | CI | CI | CI | 26 |
| | CI | CI | CI | CI | CI | CI | CI | CI | 27 |
| | CI | CI | CI | CI | CI | CI | CI | CI | 28 |
| | CI | CI | CI | CI | CI | CI | CI | CI | 29 |
| | CI | CI | CI | CI | CI | CI | CI | CI | 30 |
| | CI | CI | CI | CI | CI | CI | CI | CI | 31 |
| Header Block Type | 0 | 0 | 0 | 1 | 0 | 0 | 1 | 0 | 32 |

7.7 GENERAL HEADER BLOCK #7 (Job identification) (optional)

| | | | | | | | | | | |
|-------------------------|-------------------|-----|-----|-----|-----|-----|-----|-----|-----|----|
| Bit No. | 0 | 1 | 2 | 3 | 4 | 5 | 6 | 7 | | |
| BCD Value MSD | 8 | 4 | 2 | 1 | 8 | 4 | 2 | 1 | LSD | |
| Binary Value MSB | 128 | 64 | 32 | 16 | 8 | 4 | 2 | 1 | LSB | |
| Abbr Job Identification | JIA | JIA | JIA | JIA | JIA | JIA | JIA | JIA | 1 | |
| | JIA | JIA | JIA | JIA | JIA | JIA | JIA | JIA | 2 | |
| | JIA | JIA | JIA | JIA | JIA | JIA | JIA | JIA | 3 | |
| | JIA | JIA | JIA | JIA | JIA | JIA | JIA | JIA | 4 | |
| | JIA | JIA | JIA | JIA | JIA | JIA | JIA | JIA | 5 | |
| Job Identification | JJ | JJ | JJ | JJ | JJ | JJ | JJ | JJ | 6 | |
| | JJ | JJ | JJ | JJ | JJ | JJ | JJ | JJ | 7 | |
| | JJ | JJ | JJ | JJ | JJ | JJ | JJ | JJ | 8 | |
| | JJ | JJ | JJ | JJ | JJ | JJ | JJ | JJ | 9 | |
| | JJ | JJ | JJ | JJ | JJ | JJ | JJ | JJ | 10 | |
| | JJ | JJ | JJ | JJ | JJ | JJ | JJ | JJ | 11 | |
| | JJ | JJ | JJ | JJ | JJ | JJ | JJ | JJ | 12 | |
| | JJ | JJ | JJ | JJ | JJ | JJ | JJ | JJ | 13 | |
| | JJ | JJ | JJ | JJ | JJ | JJ | JJ | JJ | 14 | |
| | JJ | JJ | JJ | JJ | JJ | JJ | JJ | JJ | 15 | |
| | JJ | JJ | JJ | JJ | JJ | JJ | JJ | JJ | 16 | |
| | JJ | JJ | JJ | JJ | JJ | JJ | JJ | JJ | 17 | |
| | JJ | JJ | JJ | JJ | JJ | JJ | JJ | JJ | 18 | |
| | JJ | JJ | JJ | JJ | JJ | JJ | JJ | JJ | 19 | |
| | JJ | JJ | JJ | JJ | JJ | JJ | JJ | JJ | 20 | |
| | JJ | JJ | JJ | JJ | JJ | JJ | JJ | JJ | 21 | |
| | JJ | JJ | JJ | JJ | JJ | JJ | JJ | JJ | 22 | |
| | JJ | JJ | JJ | JJ | JJ | JJ | JJ | JJ | 23 | |
| | JJ | JJ | JJ | JJ | JJ | JJ | JJ | JJ | 24 | |
| | JJ | JJ | JJ | JJ | JJ | JJ | JJ | JJ | 25 | |
| | JJ | JJ | JJ | JJ | JJ | JJ | JJ | JJ | 26 | |
| | JJ | JJ | JJ | JJ | JJ | JJ | JJ | JJ | 27 | |
| | JJ | JJ | JJ | JJ | JJ | JJ | JJ | JJ | 28 | |
| | JJ | JJ | JJ | JJ | JJ | JJ | JJ | JJ | 29 | |
| | JJ | JJ | JJ | JJ | JJ | JJ | JJ | JJ | 30 | |
| | JJ | JJ | JJ | JJ | JJ | JJ | JJ | JJ | 31 | |
| | Header Block Type | 0 | 0 | 0 | 1 | 0 | 0 | 1 | 1 | 32 |

7.8 GENERAL HEADER BLOCK #8 (Line identification) (optional)

| | | | | | | | | | | |
|---------------------|-------------------|----|----|----|----|----|----|----|-----|----|
| Bit No. | 0 | 1 | 2 | 3 | 4 | 5 | 6 | 7 | | |
| BCD Value MSD | 8 | 4 | 2 | 1 | 8 | 4 | 2 | 1 | LSD | |
| Binary Value MSB | 128 | 64 | 32 | 16 | 8 | 4 | 2 | 1 | LSB | |
| Line Abbreviation | LA | LA | LA | LA | LA | LA | LA | LA | 1 | |
| | LA | LA | LA | LA | LA | LA | LA | LA | 2 | |
| | LA | LA | LA | LA | LA | LA | LA | LA | 3 | |
| | LA | LA | LA | LA | LA | LA | LA | LA | 4 | |
| | LA | LA | LA | LA | LA | LA | LA | LA | 5 | |
| | LA | LA | LA | LA | LA | LA | LA | LA | 6 | |
| | LA | LA | LA | LA | LA | LA | LA | LA | 7 | |
| Line Identification | LI | LI | LI | LI | LI | LI | LI | LI | 8 | |
| | LI | LI | LI | LI | LI | LI | LI | LI | 9 | |
| | LI | LI | LI | LI | LI | LI | LI | LI | 10 | |
| | LI | LI | LI | LI | LI | LI | LI | LI | 11 | |
| | LI | LI | LI | LI | LI | LI | LI | LI | 12 | |
| | LI | LI | LI | LI | LI | LI | LI | LI | 13 | |
| | LI | LI | LI | LI | LI | LI | LI | LI | 14 | |
| | LI | LI | LI | LI | LI | LI | LI | LI | 15 | |
| | LI | LI | LI | LI | LI | LI | LI | LI | 16 | |
| | LI | LI | LI | LI | LI | LI | LI | LI | 17 | |
| | LI | LI | LI | LI | LI | LI | LI | LI | 18 | |
| | LI | LI | LI | LI | LI | LI | LI | LI | 19 | |
| | LI | LI | LI | LI | LI | LI | LI | LI | 20 | |
| | LI | LI | LI | LI | LI | LI | LI | LI | 21 | |
| | LI | LI | LI | LI | LI | LI | LI | LI | 22 | |
| | LI | LI | LI | LI | LI | LI | LI | LI | 23 | |
| | LI | LI | LI | LI | LI | LI | LI | LI | 24 | |
| | LI | LI | LI | LI | LI | LI | LI | LI | 25 | |
| | LI | LI | LI | LI | LI | LI | LI | LI | 26 | |
| | LI | LI | LI | LI | LI | LI | LI | LI | 27 | |
| | LI | LI | LI | LI | LI | LI | LI | LI | 28 | |
| | LI | LI | LI | LI | LI | LI | LI | LI | 29 | |
| | LI | LI | LI | LI | LI | LI | LI | LI | 30 | |
| | LI | LI | LI | LI | LI | LI | LI | LI | 31 | |
| | Header Block Type | 0 | 0 | 0 | 1 | 0 | 1 | 0 | 0 | 32 |

7.9 SOURCE DESCRIPTION BLOCK (optional)

7.9.1 VIBRATOR

| | | | | | | | | | |
|--------------------------------|-------------------|--------------------|--------------------|--------------------|--------------------|--------------------|--------------------|--------------------|-----|
| Bit No. | 0 | 1 | 2 | 3 | 4 | 5 | 6 | 7 | |
| BCD Value MSD | 8 | 4 | 2 | 1 | 8 | 4 | 2 | 1 | LSD |
| Binary Value MSB | 128 | 64 | 32 | 16 | 8 | 4 | 2 | 1 | LSB |
| Expanded File No. | EF ₂₃ | EF ₂₂ | EF ₂₁ | EF ₂₀ | EF ₁₉ | EF ₁₈ | EF ₁₇ | EF ₁₆ | 1 |
| | EF ₁₅ | EF ₁₄ | EF ₁₃ | EF ₁₂ | EF ₁₁ | EF ₁₀ | EF ₉ | EF ₈ | 2 |
| | EF ₇ | EF ₆ | EF ₅ | EF ₄ | EF ₃ | EF ₂ | EF ₁ | EF ₀ | 3 |
| Source Line No. (INTEGER) | SLN ₂₃ | SLN ₂₂ | SLN ₂₁ | SLN ₂₀ | SLN ₁₉ | SLN ₁₈ | SLN ₁₇ | SLN ₁₆ | 4 |
| | SLN ₁₅ | SLN ₁₄ | SLN ₁₃ | SLN ₁₂ | SLN ₁₁ | SLN ₁₀ | SLN ₉ | SLN ₈ | 5 |
| | SLN ₇ | SLN ₆ | SLN ₅ | SLN ₄ | SLN ₃ | SLN ₂ | SLN ₁ | SLN ₀ | 6 |
| Source Line No. (FRACTION) | SLN ₋₁ | SLN ₋₂ | SLN ₋₃ | SLN ₋₄ | SLN ₋₅ | SLN ₋₆ | SLN ₋₇ | SLN ₋₈ | 7 |
| | SLN ₋₉ | SLN ₋₁₀ | SLN ₋₁₁ | SLN ₋₁₂ | SLN ₋₁₃ | SLN ₋₁₄ | SLN ₋₁₅ | SLN ₋₁₆ | 8 |
| Source Point No. (INTEGER) | SPN ₂₃ | SPN ₂₂ | SPN ₂₁ | SPN ₂₀ | SPN ₁₉ | SPN ₁₈ | SPN ₁₇ | SPN ₁₆ | 9 |
| | SPN ₁₅ | SPN ₁₄ | SPN ₁₃ | SPN ₁₂ | SPN ₁₁ | SPN ₁₀ | SPN ₉ | SPN ₈ | 10 |
| | SPN ₇ | SPN ₆ | SPN ₅ | SPN ₄ | SPN ₃ | SPN ₂ | SPN ₁ | SPN ₀ | 11 |
| Source Point No. (FRACTION) | SPN ₋₁ | SPN ₋₂ | SPN ₋₃ | SPN ₋₄ | SPN ₋₅ | SPN ₋₆ | SPN ₋₇ | SPN ₋₈ | 12 |
| | SPN ₋₉ | SPN ₋₁₀ | SPN ₋₁₁ | SPN ₋₁₂ | SPN ₋₁₃ | SPN ₋₁₄ | SPN ₋₁₅ | SPN ₋₁₆ | 13 |
| Source Point Index | SPI ₇ | SPI ₆ | SPI ₅ | SPI ₄ | SPI ₃ | SPI ₂ | SPI ₁ | SPI ₀ | 14 |
| Phase Control | PC ₇ | PC ₆ | PC ₅ | PC ₄ | PC ₃ | PC ₂ | PC ₁ | PC ₀ | 15 |
| Type Vibrator | V ₇ | V ₆ | V ₅ | V ₄ | V ₃ | V ₂ | V ₁ | V ₀ | 16 |
| Phase Angle | PA ₁₅ | PA ₁₄ | PA ₁₃ | PA ₁₂ | PA ₁₁ | PA ₁₀ | PA ₉ | PA ₈ | 17 |
| | PA ₇ | PA ₆ | PA ₅ | PA ₄ | PA ₃ | PA ₂ | PA ₁ | PA ₀ | 18 |
| Source Id | SI ₇ | SI ₆ | SI ₅ | SI ₄ | SI ₃ | SI ₂ | SI ₁ | SI ₀ | 19 |
| Source Set No. | SS ₇ | SS ₆ | SS ₅ | SS ₄ | SS ₃ | SS ₂ | SS ₁ | SS ₀ | 20 |
| Re-shoot Index | RI ₇ | RI ₆ | RI ₅ | RI ₄ | RI ₃ | RI ₂ | RI ₁ | RI ₀ | 21 |
| Group Index | GI ₇ | GI ₆ | GI ₅ | GI ₄ | GI ₃ | GI ₂ | GI ₁ | GI ₀ | 22 |
| Depth Index | DI ₇ | DI ₆ | DI ₅ | DI ₄ | DI ₃ | DI ₂ | DI ₁ | DI ₀ | 23 |
| Offset Cross-line | OX ₁₅ | OX ₁₄ | OX ₁₃ | OX ₁₂ | OX ₁₁ | OX ₁₀ | OX ₉ | OX ₈ | 24 |
| | OX ₇ | OX ₆ | OX ₅ | OX ₄ | OX ₃ | OX ₂ | OX ₁ | OX ₀ | 25 |
| Offset In-line | OI ₁₅ | OI ₁₄ | OI ₁₃ | OI ₁₂ | OI ₁₁ | OI ₁₀ | OI ₉ | OI ₈ | 26 |
| | OI ₇ | OI ₆ | OI ₅ | OI ₄ | OI ₃ | OI ₂ | OI ₁ | OI ₀ | 27 |
| Size | SZ ₁₅ | SZ ₁₄ | SZ ₁₃ | SZ ₁₂ | SZ ₁₁ | SZ ₁₀ | SZ ₉ | SZ ₈ | 28 |
| | SZ ₇ | SZ ₆ | SZ ₅ | SZ ₄ | SZ ₃ | SZ ₂ | SZ ₁ | SZ ₀ | 29 |
| Offset Depth | OD ₁₅ | OD ₁₄ | OD ₁₃ | OD ₁₂ | OD ₁₁ | OD ₁₀ | OD ₉ | OD ₈ | 30 |
| | OD ₇ | OD ₆ | OD ₅ | OD ₄ | OD ₃ | OD ₂ | OD ₁ | OD ₀ | 31 |
| Header Block Type | 0 | 0 | 0 | 1 | 0 | 1 | 0 | 1 | 32 |

7.9.2 EXPLOSIVE

| | | | | | | | | | |
|-------------------|-------------------|-------------------|-------------------|-------------------|-------------------|-------------------|-------------------|-------------------|-----|
| Bit No. | 0 | 1 | 2 | 3 | 4 | 5 | 6 | 7 | |
| BCD Value MSD | 8 | 4 | 2 | 1 | 8 | 4 | 2 | 1 | LSD |
| Binary Value MSB | 128 | 64 | 32 | 16 | 8 | 4 | 2 | 1 | LSB |
| Expanded File No. | EF ₂₃ | EF ₂₂ | EF ₂₁ | EF ₂₀ | EF ₁₉ | EF ₁₈ | EF ₁₇ | EF ₁₆ | 1 |
| | EF ₁₅ | EF ₁₄ | EF ₁₃ | EF ₁₂ | EF ₁₁ | EF ₁₀ | EF ₉ | EF ₈ | 2 |
| | EF ₇ | EF ₆ | EF ₅ | EF ₄ | EF ₃ | EF ₂ | EF ₁ | EF ₀ | 3 |
| Source Line No. | SLN ₂₃ | SLN ₂₂ | SLN ₂₁ | SLN ₂₀ | SLN ₁₉ | SLN ₁₈ | SLN ₁₇ | SLN ₁₆ | 4 |

| | | | | | | | | | |
|--------------------------------|-------------------|--------------------|--------------------|--------------------|--------------------|--------------------|--------------------|--------------------|----|
| (INTEGER) | SLN ₁₅ | SLN ₁₄ | SLN ₁₃ | SLN ₁₂ | SLN ₁₁ | SLN ₁₀ | SLN ₉ | SLN ₈ | 5 |
| | SLN ₇ | SLN ₆ | SLN ₅ | SLN ₄ | SLN ₃ | SLN ₂ | SLN ₁ | SLN ₀ | 6 |
| Source Line No. (FRACTION) | SLN ₋₁ | SLN ₋₂ | SLN ₋₃ | SLN ₋₄ | SLN ₋₅ | SLN ₋₆ | SLN ₋₇ | SLN ₋₈ | 7 |
| | SLN ₋₉ | SLN ₋₁₀ | SLN ₋₁₁ | SLN ₋₁₂ | SLN ₋₁₃ | SLN ₋₁₄ | SLN ₋₁₅ | SLN ₋₁₆ | 8 |
| Source Point No. (INTEGER) | SPN ₂₃ | SPN ₂₂ | SPN ₂₁ | SPN ₂₀ | SPN ₁₉ | SPN ₁₈ | SPN ₁₇ | SPN ₁₆ | 9 |
| | SPN ₁₅ | SPN ₁₄ | SPN ₁₃ | SPN ₁₂ | SPN ₁₁ | SPN ₁₀ | SPN ₉ | SPN ₈ | 10 |
| | SPN ₇ | SPN ₆ | SPN ₅ | SPN ₄ | SPN ₃ | SPN ₂ | SPN ₁ | SPN ₀ | 11 |
| Source Point No. (FRACTION) | SPN ₋₁ | SPN ₋₂ | SPN ₋₃ | SPN ₋₄ | SPN ₋₅ | SPN ₋₆ | SPN ₋₇ | SPN ₋₈ | 12 |
| | SPN ₋₉ | SPN ₋₁₀ | SPN ₋₁₁ | SPN ₋₁₂ | SPN ₋₁₃ | SPN ₋₁₄ | SPN ₋₁₅ | SPN ₋₁₆ | 13 |
| Source Point Index | SPI ₇ | SPI ₆ | SPI ₅ | SPI ₄ | SPI ₃ | SPI ₂ | SPI ₁ | SPI ₀ | 14 |
| Depth | DE ₁₅ | DE ₁₄ | DE ₁₃ | DE ₁₂ | DE ₁₁ | DE ₁₀ | DE ₉ | DE ₈ | 15 |
| | DE ₇ | DE ₆ | DE ₅ | DE ₄ | DE ₃ | DE ₂ | DE ₁ | DE ₀ | 16 |
| Charge Length | CL ₇ | CL ₆ | CL ₅ | CL ₄ | CL ₃ | CL ₂ | CL ₁ | CL ₀ | 17 |
| Soil Type | ST ₇ | ST ₆ | ST ₅ | ST ₄ | ST ₃ | ST ₂ | ST ₁ | ST ₀ | 18 |
| Source Id | SI ₇ | SI ₆ | SI ₅ | SI ₄ | SI ₃ | SI ₂ | SI ₁ | SI ₀ | 19 |
| Source Set No. | SS ₇ | SS ₆ | SS ₅ | SS ₄ | SS ₃ | SS ₂ | SS ₁ | SS ₀ | 20 |
| Re-shoot Index | RI ₇ | RI ₆ | RI ₅ | RI ₄ | RI ₃ | RI ₂ | RI ₁ | RI ₀ | 21 |
| Group Index | GI ₇ | GI ₆ | GI ₅ | GI ₄ | GI ₃ | GI ₂ | GI ₁ | GI ₀ | 22 |
| Depth Index | DI ₇ | DI ₆ | DI ₅ | DI ₄ | DI ₃ | DI ₂ | DI ₁ | DI ₀ | 23 |
| Offset Cross-line | OX ₁₅ | OX ₁₄ | OX ₁₃ | OX ₁₂ | OX ₁₁ | OX ₁₀ | OX ₉ | OX ₈ | 24 |
| | OX ₇ | OX ₆ | OX ₅ | OX ₄ | OX ₃ | OX ₂ | OX ₁ | OX ₀ | 25 |
| Offset In-line | OI ₁₅ | OI ₁₄ | OI ₁₃ | OI ₁₂ | OI ₁₁ | OI ₁₀ | OI ₉ | OI ₈ | 26 |
| | OI ₇ | OI ₆ | OI ₅ | OI ₄ | OI ₃ | OI ₂ | OI ₁ | OI ₀ | 27 |
| Size | SZ ₁₅ | SZ ₁₄ | SZ ₁₃ | SZ ₁₂ | SZ ₁₁ | SZ ₁₀ | SZ ₉ | SZ ₈ | 28 |
| | SZ ₇ | SZ ₆ | SZ ₅ | SZ ₄ | SZ ₃ | SZ ₂ | SZ ₁ | SZ ₀ | 29 |
| Offset Depth | OD ₁₅ | OD ₁₄ | OD ₁₃ | OD ₁₂ | OD ₁₁ | OD ₁₀ | OD ₉ | OD ₈ | 30 |
| | OD ₇ | OD ₆ | OD ₅ | OD ₄ | OD ₃ | OD ₂ | OD ₁ | OD ₀ | 31 |
| Header Block Type | 0 | 0 | 0 | 1 | 0 | 1 | 1 | 0 | 32 |

7.9.3 AIRGUN

| | | | | | | | | | |
|--------------------------------|-------------------|--------------------|--------------------|--------------------|--------------------|--------------------|--------------------|--------------------|-----|
| Bit No. | 0 | 1 | 2 | 3 | 4 | 5 | 6 | 7 | |
| BCD Value MSD | 8 | 4 | 2 | 1 | 8 | 4 | 2 | 1 | LSD |
| Binary Value MSB | 128 | 64 | 32 | 16 | 8 | 4 | 2 | 1 | LSB |
| Expanded File No. | EF ₂₃ | EF ₂₂ | EF ₂₁ | EF ₂₀ | EF ₁₉ | EF ₁₈ | EF ₁₇ | EF ₁₆ | 1 |
| | EF ₁₅ | EF ₁₄ | EF ₁₃ | EF ₁₂ | EF ₁₁ | EF ₁₀ | EF ₉ | EF ₈ | 2 |
| | EF ₇ | EF ₆ | EF ₅ | EF ₄ | EF ₃ | EF ₂ | EF ₁ | EF ₀ | 3 |
| Source Line No. (INTEGER) | SLN ₂₃ | SLN ₂₂ | SLN ₂₁ | SLN ₂₀ | SLN ₁₉ | SLN ₁₈ | SLN ₁₇ | SLN ₁₆ | 4 |
| | SLN ₁₅ | SLN ₁₄ | SLN ₁₃ | SLN ₁₂ | SLN ₁₁ | SLN ₁₀ | SLN ₉ | SLN ₈ | 5 |
| | SLN ₇ | SLN ₆ | SLN ₅ | SLN ₄ | SLN ₃ | SLN ₂ | SLN ₁ | SLN ₀ | 6 |
| Source Line No. (FRACTION) | SLN ₋₁ | SLN ₋₂ | SLN ₋₃ | SLN ₋₄ | SLN ₋₅ | SLN ₋₆ | SLN ₋₇ | SLN ₋₈ | 7 |
| | SLN ₋₉ | SLN ₋₁₀ | SLN ₋₁₁ | SLN ₋₁₂ | SLN ₋₁₃ | SLN ₋₁₄ | SLN ₋₁₅ | SLN ₋₁₆ | 8 |
| Source Point No. (INTEGER) | SPN ₂₃ | SPN ₂₂ | SPN ₂₁ | SPN ₂₀ | SPN ₁₉ | SPN ₁₈ | SPN ₁₇ | SPN ₁₆ | 9 |
| | SPN ₁₅ | SPN ₁₄ | SPN ₁₃ | SPN ₁₂ | SPN ₁₁ | SPN ₁₀ | SPN ₉ | SPN ₈ | 10 |
| | SPN ₇ | SPN ₆ | SPN ₅ | SPN ₄ | SPN ₃ | SPN ₂ | SPN ₁ | SPN ₀ | 11 |
| Source Point No. (FRACTION) | SPN ₋₁ | SPN ₋₂ | SPN ₋₃ | SPN ₋₄ | SPN ₋₅ | SPN ₋₆ | SPN ₋₇ | SPN ₋₈ | 12 |
| | SPN ₋₉ | SPN ₋₁₀ | SPN ₋₁₁ | SPN ₋₁₂ | SPN ₋₁₃ | SPN ₋₁₄ | SPN ₋₁₅ | SPN ₋₁₆ | 13 |
| Source Point Index | SPI ₇ | SPI ₆ | SPI ₅ | SPI ₄ | SPI ₃ | SPI ₂ | SPI ₁ | SPI ₀ | 14 |

| | | | | | | | | | |
|-------------------|------------------|------------------|------------------|------------------|------------------|------------------|-----------------|-----------------|----|
| Depth | DE ₁₅ | DE ₁₄ | DE ₁₃ | DE ₁₂ | DE ₁₁ | DE ₁₀ | DE ₉ | DE ₈ | 15 |
| | DE ₇ | DE ₆ | DE ₅ | DE ₄ | DE ₃ | DE ₂ | DE ₁ | DE ₀ | 16 |
| Air Pressure | AP ₁₅ | AP ₁₄ | AP ₁₃ | AP ₁₂ | AP ₁₁ | AP ₁₀ | AP ₉ | AP ₈ | 17 |
| | AP ₇ | AP ₆ | AP ₅ | AP ₄ | AP ₃ | AP ₂ | AP ₁ | AP ₀ | 18 |
| Source Id | SI ₇ | SI ₆ | SI ₅ | SI ₄ | SI ₃ | SI ₂ | SI ₁ | SI ₀ | 19 |
| Source Set No. | SS ₇ | SS ₆ | SS ₅ | SS ₄ | SS ₃ | SS ₂ | SS ₁ | SS ₀ | 20 |
| Re-shoot Index | RI ₇ | RI ₆ | RI ₅ | RI ₄ | RI ₃ | RI ₂ | RI ₁ | RI ₀ | 21 |
| Group Index | GI ₇ | GI ₆ | GI ₅ | GI ₄ | GI ₃ | GI ₂ | GI ₁ | GI ₀ | 22 |
| Depth Index | DI ₇ | DI ₆ | DI ₅ | DI ₄ | DI ₃ | DI ₂ | DI ₁ | DI ₀ | 23 |
| Offset Cross-line | OX ₁₅ | OX ₁₄ | OX ₁₃ | OX ₁₂ | OX ₁₁ | OX ₁₀ | OX ₉ | OX ₈ | 24 |
| | OX ₇ | OX ₆ | OX ₅ | OX ₄ | OX ₃ | OX ₂ | OX ₁ | OX ₀ | 25 |
| Offset In-line | OI ₁₅ | OI ₁₄ | OI ₁₃ | OI ₁₂ | OI ₁₁ | OI ₁₀ | OI ₉ | OI ₈ | 26 |
| | OI ₇ | OI ₆ | OI ₅ | OI ₄ | OI ₃ | OI ₂ | OI ₁ | OI ₀ | 27 |
| Size | SZ ₁₅ | SZ ₁₄ | SZ ₁₃ | SZ ₁₂ | SZ ₁₁ | SZ ₁₀ | SZ ₉ | SZ ₈ | 28 |
| | SZ ₇ | SZ ₆ | SZ ₅ | SZ ₄ | SZ ₃ | SZ ₂ | SZ ₁ | SZ ₀ | 29 |
| Offset Depth | OD ₁₅ | OD ₁₄ | OD ₁₃ | OD ₁₂ | OD ₁₁ | OD ₁₀ | OD ₉ | OD ₈ | 30 |
| | OD ₇ | OD ₆ | OD ₅ | OD ₄ | OD ₃ | OD ₂ | OD ₁ | OD ₀ | 31 |
| Header Block Type | 0 | 0 | 0 | 1 | 0 | 1 | 1 | 1 | 32 |

7.9.4 WATERGUN

| | | | | | | | | | |
|--------------------------------|-------------------|--------------------|--------------------|--------------------|--------------------|--------------------|--------------------|--------------------|-----|
| Bit No. | 0 | 1 | 2 | 3 | 4 | 5 | 6 | 7 | |
| BCD Value MSD | 8 | 4 | 2 | 1 | 8 | 4 | 2 | 1 | LSD |
| Binary Value MSB | 128 | 64 | 32 | 16 | 8 | 4 | 2 | 1 | LSB |
| Expanded File No. | EF ₂₃ | EF ₂₂ | EF ₂₁ | EF ₂₀ | EF ₁₉ | EF ₁₈ | EF ₁₇ | EF ₁₆ | 1 |
| | EF ₁₅ | EF ₁₄ | EF ₁₃ | EF ₁₂ | EF ₁₁ | EF ₁₀ | EF ₉ | EF ₈ | 2 |
| | EF ₇ | EF ₆ | EF ₅ | EF ₄ | EF ₃ | EF ₂ | EF ₁ | EF ₀ | 3 |
| Source Line No. (INTEGER) | SLN ₂₃ | SLN ₂₂ | SLN ₂₁ | SLN ₂₀ | SLN ₁₉ | SLN ₁₈ | SLN ₁₇ | SLN ₁₆ | 4 |
| | SLN ₁₅ | SLN ₁₄ | SLN ₁₃ | SLN ₁₂ | SLN ₁₁ | SLN ₁₀ | SLN ₉ | SLN ₈ | 5 |
| | SLN ₇ | SLN ₆ | SLN ₅ | SLN ₄ | SLN ₃ | SLN ₂ | SLN ₁ | SLN ₀ | 6 |
| Source Line No. (FRACTION) | SLN ₋₁ | SLN ₋₂ | SLN ₋₃ | SLN ₋₄ | SLN ₋₅ | SLN ₋₆ | SLN ₋₇ | SLN ₋₈ | 7 |
| | SLN ₋₉ | SLN ₋₁₀ | SLN ₋₁₁ | SLN ₋₁₂ | SLN ₋₁₃ | SLN ₋₁₄ | SLN ₋₁₅ | SLN ₋₁₆ | 8 |
| Source Point No. (INTEGER) | SPN ₂₃ | SPN ₂₂ | SPN ₂₁ | SPN ₂₀ | SPN ₁₉ | SPN ₁₈ | SPN ₁₇ | SPN ₁₆ | 9 |
| | SPN ₁₅ | SPN ₁₄ | SPN ₁₃ | SPN ₁₂ | SPN ₁₁ | SPN ₁₀ | SPN ₉ | SPN ₈ | 10 |
| | SPN ₇ | SPN ₆ | SPN ₅ | SPN ₄ | SPN ₃ | SPN ₂ | SPN ₁ | SPN ₀ | 11 |
| Source Point No. (FRACTION) | SPN ₋₁ | SPN ₋₂ | SPN ₋₃ | SPN ₋₄ | SPN ₋₅ | SPN ₋₆ | SPN ₋₇ | SPN ₋₈ | 12 |
| | SPN ₋₉ | SPN ₋₁₀ | SPN ₋₁₁ | SPN ₋₁₂ | SPN ₋₁₃ | SPN ₋₁₄ | SPN ₋₁₅ | SPN ₋₁₆ | 13 |
| Source Point Index | SPI ₇ | SPI ₆ | SPI ₅ | SPI ₄ | SPI ₃ | SPI ₂ | SPI ₁ | SPI ₀ | 14 |
| Depth | DE ₁₅ | DE ₁₄ | DE ₁₃ | DE ₁₂ | DE ₁₁ | DE ₁₀ | DE ₉ | DE ₈ | 15 |
| | DE ₇ | DE ₆ | DE ₅ | DE ₄ | DE ₃ | DE ₂ | DE ₁ | DE ₀ | 16 |
| Air Pressure | AP ₁₅ | AP ₁₄ | AP ₁₃ | AP ₁₂ | AP ₁₁ | AP ₁₀ | AP ₉ | AP ₈ | 17 |
| | AP ₇ | AP ₆ | AP ₅ | AP ₄ | AP ₃ | AP ₂ | AP ₁ | AP ₀ | 18 |
| Source Id | SI ₇ | SI ₆ | SI ₅ | SI ₄ | SI ₃ | SI ₂ | SI ₁ | SI ₀ | 19 |
| Source Set No. | SS ₇ | SS ₆ | SS ₅ | SS ₄ | SS ₃ | SS ₂ | SS ₁ | SS ₀ | 20 |
| Re-shoot Index | RI ₇ | RI ₆ | RI ₅ | RI ₄ | RI ₃ | RI ₂ | RI ₁ | RI ₀ | 21 |
| Group Index | GI ₇ | GI ₆ | GI ₅ | GI ₄ | GI ₃ | GI ₂ | GI ₁ | GI ₀ | 22 |
| Depth Index | DI ₇ | DI ₆ | DI ₅ | DI ₄ | DI ₃ | DI ₂ | DI ₁ | DI ₀ | 23 |
| Offset Cross-line | OX ₁₅ | OX ₁₄ | OX ₁₃ | OX ₁₂ | OX ₁₁ | OX ₁₀ | OX ₉ | OX ₈ | 24 |

| | | | | | | | | | |
|-------------------|------------------|------------------|------------------|------------------|------------------|------------------|-----------------|-----------------|----|
| | OX ₇ | OX ₆ | OX ₅ | OX ₄ | OX ₃ | OX ₂ | OX ₁ | OX ₀ | 25 |
| Offset In-line | OI ₁₅ | OI ₁₄ | OI ₁₃ | OI ₁₂ | OI ₁₁ | OI ₁₀ | OI ₉ | OI ₈ | 26 |
| | OI ₇ | OI ₆ | OI ₅ | OI ₄ | OI ₃ | OI ₂ | OI ₁ | OI ₀ | 27 |
| Size | SZ ₁₅ | SZ ₁₄ | SZ ₁₃ | SZ ₁₂ | SZ ₁₁ | SZ ₁₀ | SZ ₉ | SZ ₈ | 28 |
| | SZ ₇ | SZ ₆ | SZ ₅ | SZ ₄ | SZ ₃ | SZ ₂ | SZ ₁ | SZ ₀ | 29 |
| Offset Depth | OD ₁₅ | OD ₁₄ | OD ₁₃ | OD ₁₂ | OD ₁₁ | OD ₁₀ | OD ₉ | OD ₈ | 30 |
| | OD ₇ | OD ₆ | OD ₅ | OD ₄ | OD ₃ | OD ₂ | OD ₁ | OD ₀ | 31 |
| Header Block Type | 0 | 0 | 0 | 1 | 1 | 0 | 0 | 0 | 32 |

7.9.5 ELECTROMAGNETIC SOURCE

| | | | | | | | | | |
|--------------------------------|-------------------|--------------------|--------------------|--------------------|--------------------|--------------------|--------------------|--------------------|-----|
| Bit No. | 0 | 1 | 2 | 3 | 4 | 5 | 6 | 7 | |
| BCD Value MSD | 8 | 4 | 2 | 1 | 8 | 4 | 2 | 1 | LSD |
| Binary Value MSB | 128 | 64 | 32 | 16 | 8 | 4 | 2 | 1 | LSB |
| Expanded File No. | EF ₂₃ | EF ₂₂ | EF ₂₁ | EF ₂₀ | EF ₁₉ | EF ₁₈ | EF ₁₇ | EF ₁₆ | 1 |
| | EF ₁₅ | EF ₁₄ | EF ₁₃ | EF ₁₂ | EF ₁₁ | EF ₁₀ | EF ₉ | EF ₈ | 2 |
| | EF ₇ | EF ₆ | EF ₅ | EF ₄ | EF ₃ | EF ₂ | EF ₁ | EF ₀ | 3 |
| Source Line No. (INTEGER) | SLN ₂₃ | SLN ₂₂ | SLN ₂₁ | SLN ₂₀ | SLN ₁₉ | SLN ₁₈ | SLN ₁₇ | SLN ₁₆ | 4 |
| | SLN ₁₅ | SLN ₁₄ | SLN ₁₃ | SLN ₁₂ | SLN ₁₁ | SLN ₁₀ | SLN ₉ | SLN ₈ | 5 |
| | SLN ₇ | SLN ₆ | SLN ₅ | SLN ₄ | SLN ₃ | SLN ₂ | SLN ₁ | SLN ₀ | 6 |
| Source Line No. (FRACTION) | SLN ₋₁ | SLN ₋₂ | SLN ₋₃ | SLN ₋₄ | SLN ₋₅ | SLN ₋₆ | SLN ₋₇ | SLN ₋₈ | 7 |
| | SLN ₋₉ | SLN ₋₁₀ | SLN ₋₁₁ | SLN ₋₁₂ | SLN ₋₁₃ | SLN ₋₁₄ | SLN ₋₁₅ | SLN ₋₁₆ | 8 |
| Source Point No. (INTEGER) | SPN ₂₃ | SPN ₂₂ | SPN ₂₁ | SPN ₂₀ | SPN ₁₉ | SPN ₁₈ | SPN ₁₇ | SPN ₁₆ | 9 |
| | SPN ₁₅ | SPN ₁₄ | SPN ₁₃ | SPN ₁₂ | SPN ₁₁ | SPN ₁₀ | SPN ₉ | SPN ₈ | 10 |
| | SPN ₇ | SPN ₆ | SPN ₅ | SPN ₄ | SPN ₃ | SPN ₂ | SPN ₁ | SPN ₀ | 11 |
| Source Point No. (FRACTION) | SPN ₋₁ | SPN ₋₂ | SPN ₋₃ | SPN ₋₄ | SPN ₋₅ | SPN ₋₆ | SPN ₋₇ | SPN ₋₈ | 12 |
| | SPN ₋₉ | SPN ₋₁₀ | SPN ₋₁₁ | SPN ₋₁₂ | SPN ₋₁₃ | SPN ₋₁₄ | SPN ₋₁₅ | SPN ₋₁₆ | 13 |
| Source Point Index | SPI ₇ | SPI ₆ | SPI ₅ | SPI ₄ | SPI ₃ | SPI ₂ | SPI ₁ | SPI ₀ | 14 |
| Source Type | ST ₇ | ST ₆ | ST ₅ | ST ₄ | ST ₃ | ST ₂ | ST ₁ | ST ₀ | 15 |
| Moment | MO ₂₃ | MO ₂₂ | MO ₂₁ | MO ₂₀ | MO ₁₉ | MO ₁₈ | MO ₁₇ | MO ₁₆ | 16 |
| | MO ₁₅ | MO ₁₄ | MO ₁₃ | MO ₁₂ | MO ₁₁ | MO ₁₀ | MO ₉ | MO ₈ | 17 |
| | MO ₇ | MO ₆ | MO ₅ | MO ₄ | MO ₃ | MO ₂ | MO ₁ | MO ₀ | 18 |
| Source Id | SI ₇ | SI ₆ | SI ₅ | SI ₄ | SI ₃ | SI ₂ | SI ₁ | SI ₀ | 19 |
| Source Set No. | SS ₇ | SS ₆ | SS ₅ | SS ₄ | SS ₃ | SS ₂ | SS ₁ | SS ₀ | 20 |
| Re-shoot Index | RI ₇ | RI ₆ | RI ₅ | RI ₄ | RI ₃ | RI ₂ | RI ₁ | RI ₀ | 21 |
| Group Index | GI ₇ | GI ₆ | GI ₅ | GI ₄ | GI ₃ | GI ₂ | GI ₁ | GI ₀ | 22 |
| Depth Index | DI ₇ | DI ₆ | DI ₅ | DI ₄ | DI ₃ | DI ₂ | DI ₁ | DI ₀ | 23 |
| Offset Cross-line | OX ₁₅ | OX ₁₄ | OX ₁₃ | OX ₁₂ | OX ₁₁ | OX ₁₀ | OX ₉ | OX ₈ | 24 |
| | OX ₇ | OX ₆ | OX ₅ | OX ₄ | OX ₃ | OX ₂ | OX ₁ | OX ₀ | 25 |
| Offset In-line | OI ₁₅ | OI ₁₄ | OI ₁₃ | OI ₁₂ | OI ₁₁ | OI ₁₀ | OI ₉ | OI ₈ | 26 |
| | OI ₇ | OI ₆ | OI ₅ | OI ₄ | OI ₃ | OI ₂ | OI ₁ | OI ₀ | 27 |
| Current/Voltage | CV ₁₅ | CV ₁₄ | CV ₁₃ | CV ₁₂ | CV ₁₁ | CV ₁₀ | CV ₉ | CV ₈ | 28 |
| | CV ₇ | CV ₆ | CV ₅ | CV ₄ | CV ₃ | CV ₂ | CV ₁ | CV ₀ | 29 |
| Offset Depth | OD ₁₅ | OD ₁₄ | OD ₁₃ | OD ₁₂ | OD ₁₁ | OD ₁₀ | OD ₉ | OD ₈ | 30 |
| | OD ₇ | OD ₆ | OD ₅ | OD ₄ | OD ₃ | OD ₂ | OD ₁ | OD ₀ | 31 |
| Header Block Type | 0 | 0 | 0 | 1 | 1 | 0 | 0 | 1 | 32 |

7.9.6 OTHER SOURCE

| | | | | | | | | | |
|--------------------------------|-------------------|--------------------|--------------------|--------------------|--------------------|--------------------|--------------------|--------------------|-----|
| Bit No. | 0 | 1 | 2 | 3 | 4 | 5 | 6 | 7 | |
| BCD Value MSD | 8 | 4 | 2 | 1 | 8 | 4 | 2 | 1 | LSD |
| Binary Value MSB | 128 | 64 | 32 | 16 | 8 | 4 | 2 | 1 | LSB |
| Expanded File No. | EF ₂₃ | EF ₂₂ | EF ₂₁ | EF ₂₀ | EF ₁₉ | EF ₁₈ | EF ₁₇ | EF ₁₆ | 1 |
| | EF ₁₅ | EF ₁₄ | EF ₁₃ | EF ₁₂ | EF ₁₁ | EF ₁₀ | EF ₉ | EF ₈ | 2 |
| | EF ₇ | EF ₆ | EF ₅ | EF ₄ | EF ₃ | EF ₂ | EF ₁ | EF ₀ | 3 |
| Source Line No. (INTEGER) | SLN ₂₃ | SLN ₂₂ | SLN ₂₁ | SLN ₂₀ | SLN ₁₉ | SLN ₁₈ | SLN ₁₇ | SLN ₁₆ | 4 |
| | SLN ₁₅ | SLN ₁₄ | SLN ₁₃ | SLN ₁₂ | SLN ₁₁ | SLN ₁₀ | SLN ₉ | SLN ₈ | 5 |
| | SLN ₇ | SLN ₆ | SLN ₅ | SLN ₄ | SLN ₃ | SLN ₂ | SLN ₁ | SLN ₀ | 6 |
| Source Line No. (FRACTION) | SLN ₋₁ | SLN ₋₂ | SLN ₋₃ | SLN ₋₄ | SLN ₋₅ | SLN ₋₆ | SLN ₋₇ | SLN ₋₈ | 7 |
| | SLN ₋₉ | SLN ₋₁₀ | SLN ₋₁₁ | SLN ₋₁₂ | SLN ₋₁₃ | SLN ₋₁₄ | SLN ₋₁₅ | SLN ₋₁₆ | 8 |
| Source Point No. (INTEGER) | SPN ₂₃ | SPN ₂₂ | SPN ₂₁ | SPN ₂₀ | SPN ₁₉ | SPN ₁₈ | SPN ₁₇ | SPN ₁₆ | 9 |
| | SPN ₁₅ | SPN ₁₄ | SPN ₁₃ | SPN ₁₂ | SPN ₁₁ | SPN ₁₀ | SPN ₉ | SPN ₈ | 10 |
| | SPN ₇ | SPN ₆ | SPN ₅ | SPN ₄ | SPN ₃ | SPN ₂ | SPN ₁ | SPN ₀ | 11 |
| Source Point No. (FRACTION) | SPN ₋₁ | SPN ₋₂ | SPN ₋₃ | SPN ₋₄ | SPN ₋₅ | SPN ₋₆ | SPN ₋₇ | SPN ₋₈ | 12 |
| | SPN ₋₉ | SPN ₋₁₀ | SPN ₋₁₁ | SPN ₋₁₂ | SPN ₋₁₃ | SPN ₋₁₄ | SPN ₋₁₅ | SPN ₋₁₆ | 13 |
| Source Point Index | SPI ₇ | SPI ₆ | SPI ₅ | SPI ₄ | SPI ₃ | SPI ₂ | SPI ₁ | SPI ₀ | 14 |
| | X | X | X | X | X | X | X | X | 15 |
| | X | X | X | X | X | X | X | X | 16 |
| | X | X | X | X | X | X | X | X | 17 |
| | X | X | X | X | X | X | X | X | 18 |
| Source Id | SI ₇ | SI ₆ | SI ₅ | SI ₄ | SI ₃ | SI ₂ | SI ₁ | SI ₀ | 19 |
| Source Set No. | SS ₇ | SS ₆ | SS ₅ | SS ₄ | SS ₃ | SS ₂ | SS ₁ | SS ₀ | 20 |
| Re-shoot Index | RI ₇ | RI ₆ | RI ₅ | RI ₄ | RI ₃ | RI ₂ | RI ₁ | RI ₀ | 21 |
| Group Index | GI ₇ | GI ₆ | GI ₅ | GI ₄ | GI ₃ | GI ₂ | GI ₁ | GI ₀ | 22 |
| Depth Index | DI ₇ | DI ₆ | DI ₅ | DI ₄ | DI ₃ | DI ₂ | DI ₁ | DI ₀ | 23 |
| Offset Cross-line | OX ₁₅ | OX ₁₄ | OX ₁₃ | OX ₁₂ | OX ₁₁ | OX ₁₀ | OX ₉ | OX ₈ | 24 |
| | OX ₇ | OX ₆ | OX ₅ | OX ₄ | OX ₃ | OX ₂ | OX ₁ | OX ₀ | 25 |
| Offset In-line | OI ₁₅ | OI ₁₄ | OI ₁₃ | OI ₁₂ | OI ₁₁ | OI ₁₀ | OI ₉ | OI ₈ | 26 |
| | OI ₇ | OI ₆ | OI ₅ | OI ₄ | OI ₃ | OI ₂ | OI ₁ | OI ₀ | 27 |
| | X | X | X | X | X | X | X | X | 28 |
| | X | X | X | X | X | X | X | X | 29 |
| Offset Depth | OD ₁₅ | OD ₁₄ | OD ₁₃ | OD ₁₂ | OD ₁₁ | OD ₁₀ | OD ₉ | OD ₈ | 30 |
| | OD ₇ | OD ₆ | OD ₅ | OD ₄ | OD ₃ | OD ₂ | OD ₁ | OD ₀ | 31 |
| Header Block Type | 0 | 0 | 0 | 1 | 1 | 1 | 1 | 1 | 32 |

7.10 ADDITIONAL SOURCE INFO (optional)

Follows the Source Description Block

| | | | | | | | | | |
|---------------|---|---|---|---|---|---|---|---|-----|
| Bit No. | 0 | 1 | 2 | 3 | 4 | 5 | 6 | 7 | |
| BCD Value MSD | 8 | 4 | 2 | 1 | 8 | 4 | 2 | 1 | LSD |

| Binary Value MSB | 128 | 64 | 32 | 16 | 8 | 4 | 2 | 1 | LSB |
|-------------------|------------------|------------------|------------------|------------------|------------------|------------------|------------------|------------------|-----|
| Time | T ₆₃ | T ₆₂ | T ₆₁ | T ₆₀ | T ₅₉ | T ₅₈ | T ₅₇ | T ₅₆ | 1 |
| | T ₅₅ | T ₅₄ | T ₅₃ | T ₅₂ | T ₅₁ | T ₅₀ | T ₄₉ | T ₄₈ | 2 |
| | T ₄₇ | T ₄₆ | T ₄₅ | T ₄₄ | T ₄₃ | T ₄₂ | T ₄₁ | T ₄₀ | 3 |
| | T ₃₉ | T ₃₈ | T ₃₇ | T ₃₆ | T ₃₅ | T ₃₄ | T ₃₃ | T ₃₂ | 4 |
| | T ₃₁ | T ₃₀ | T ₂₉ | T ₂₈ | T ₂₇ | T ₂₆ | T ₂₅ | T ₂₄ | 5 |
| | T ₂₃ | T ₂₂ | T ₂₁ | T ₂₀ | T ₁₉ | T ₁₈ | T ₁₇ | T ₁₆ | 6 |
| | T ₁₅ | T ₁₄ | T ₁₃ | T ₁₂ | T ₁₁ | T ₁₀ | T ₉ | T ₈ | 7 |
| | T ₇ | T ₆ | T ₅ | T ₄ | T ₃ | T ₂ | T ₁ | T ₀ | 8 |
| Source Status | SST ₇ | SST ₆ | SST ₅ | SST ₄ | SST ₃ | SST ₂ | SST ₁ | SST ₀ | 9 |
| Source Id | SI ₇ | SI ₆ | SI ₅ | SI ₄ | SI ₃ | SI ₂ | SI ₁ | SI ₀ | 10 |
| Source Moving | MV ₇ | MV ₆ | MV ₅ | MV ₄ | MV ₃ | MV ₂ | MV ₁ | MV ₀ | 11 |
| Error description | ED | ED | ED | ED | ED | ED | ED | ED | 12 |
| | ED | ED | ED | ED | ED | ED | ED | ED | 13 |
| | ED | ED | ED | ED | ED | ED | ED | ED | 14 |
| | ED | ED | ED | ED | ED | ED | ED | ED | 15 |
| | ED | ED | ED | ED | ED | ED | ED | ED | 16 |
| | ED | ED | ED | ED | ED | ED | ED | ED | 17 |
| | ED | ED | ED | ED | ED | ED | ED | ED | 18 |
| | ED | ED | ED | ED | ED | ED | ED | ED | 19 |
| | ED | ED | ED | ED | ED | ED | ED | ED | 20 |
| | ED | ED | ED | ED | ED | ED | ED | ED | 21 |
| | ED | ED | ED | ED | ED | ED | ED | ED | 22 |
| | ED | ED | ED | ED | ED | ED | ED | ED | 23 |
| | ED | ED | ED | ED | ED | ED | ED | ED | 24 |
| | ED | ED | ED | ED | ED | ED | ED | ED | 25 |
| ED | ED | ED | ED | ED | ED | ED | ED | 26 | |
| ED | ED | ED | ED | ED | ED | ED | ED | 27 | |
| ED | ED | ED | ED | ED | ED | ED | ED | 28 | |
| ED | ED | ED | ED | ED | ED | ED | ED | 29 | |
| ED | ED | ED | ED | ED | ED | ED | ED | 30 | |
| ED | ED | ED | ED | ED | ED | ED | ED | 31 | |
| Header Block Type | 0 | 0 | 0 | 1 | 1 | 0 | 1 | 0 | 32 |

7.11 SOURCE AUXILIARY CHANNEL REFERENCE (optional)

Follows the Source Description Block

| Bit No. | 0 | 1 | 2 | 3 | 4 | 5 | 6 | 7 | |
|----------------------|-------------------|-------------------|-------------------|-------------------|-------------------|-------------------|-------------------|-------------------|-----|
| BCD Value MSD | 8 | 4 | 2 | 1 | 8 | 4 | 2 | 1 | LSD |
| Binary Value MSB | 128 | 64 | 32 | 16 | 8 | 4 | 2 | 1 | LSB |
| Source Id | SI ₇ | SI ₆ | SI ₅ | SI ₄ | SI ₃ | SI ₂ | SI ₁ | SI ₀ | 1 |
| Scan Type Number 1 | ST1 ₁ | ST1 ₁ | ST1 ₁ | ST1 ₁ | ST1 ₂ | ST1 ₂ | ST1 ₂ | ST1 ₂ | 2 |
| Channel Set Number 1 | CS1 ₁₅ | CS1 ₁₄ | CS1 ₁₃ | CS1 ₁₂ | CS1 ₁₁ | CS1 ₁₀ | CS1 ₉ | CS1 ₈ | 3 |
| | CS1 ₇ | CS1 ₆ | CS1 ₅ | CS1 ₄ | CS1 ₃ | CS1 ₂ | CS1 ₁ | CS1 ₀ | 4 |
| Trace Number 1 | TN1 ₂₃ | TN1 ₂₂ | TN1 ₂₁ | TN1 ₂₀ | TN1 ₁₉ | TN1 ₁₈ | TN1 ₁₇ | TN1 ₁₆ | 5 |
| | TN1 ₁₅ | TN1 ₁₄ | TN1 ₁₃ | TN1 ₁₂ | TN1 ₁₁ | TN1 ₁₀ | TN1 ₉ | TN1 ₈ | 6 |
| | TN1 ₇ | TN1 ₆ | TN1 ₅ | TN1 ₄ | TN1 ₃ | TN1 ₂ | TN1 ₁ | TN1 ₀ | 7 |

| | | | | | | | | | |
|----------------------|-------------------|-------------------|-------------------|-------------------|-------------------|-------------------|-------------------|-------------------|----|
| Scan Type Number 2 | ST2 ₁ | ST2 ₁ | ST2 ₁ | ST2 ₁ | ST2 ₂ | ST2 ₂ | ST2 ₂ | ST2 ₂ | 8 |
| Channel Set Number 2 | CS2 ₁₅ | CS2 ₁₄ | CS2 ₁₃ | CS2 ₁₂ | CS2 ₁₁ | CS2 ₁₀ | CS2 ₉ | CS2 ₈ | 9 |
| | CS2 ₇ | CS2 ₆ | CS2 ₅ | CS2 ₄ | CS2 ₃ | CS2 ₂ | CS2 ₁ | CS2 ₀ | 10 |
| Trace Number 2 | TN2 ₂₃ | TN2 ₂₂ | TN2 ₂₁ | TN2 ₂₀ | TN2 ₁₉ | TN2 ₁₈ | TN2 ₁₇ | TN2 ₁₆ | 11 |
| | TN2 ₁₅ | TN2 ₁₄ | TN2 ₁₃ | TN2 ₁₂ | TN2 ₁₁ | TN2 ₁₀ | TN2 ₉ | TN1 ₈ | 12 |
| | TN2 ₇ | TN2 ₆ | TN2 ₅ | TN2 ₄ | TN2 ₃ | TN2 ₂ | TN2 ₁ | TN2 ₀ | 13 |
| Scan Type Number 3 | ST3 ₁ | ST3 ₁ | ST3 ₁ | ST3 ₁ | ST3 ₂ | ST3 ₂ | ST3 ₂ | ST3 ₂ | 14 |
| Channel Set Number 3 | CS3 ₁₅ | CS3 ₁₄ | CS3 ₁₃ | CS3 ₁₂ | CS3 ₁₁ | CS3 ₁₀ | CS3 ₉ | CS3 ₈ | 15 |
| | CS3 ₇ | CS3 ₆ | CS3 ₅ | CS3 ₄ | CS3 ₃ | CS3 ₂ | CS3 ₁ | CS3 ₀ | 16 |
| Trace Number 3 | TN3 ₂₃ | TN3 ₂₂ | TN3 ₂₁ | TN3 ₂₀ | TN3 ₁₉ | TN3 ₁₈ | TN3 ₁₇ | TN3 ₁₆ | 17 |
| | TN3 ₁₅ | TN3 ₁₄ | TN3 ₁₃ | TN3 ₁₂ | TN3 ₁₁ | TN3 ₁₀ | TN3 ₉ | TN3 ₈ | 18 |
| | TN3 ₇ | TN3 ₆ | TN3 ₅ | TN3 ₄ | TN3 ₃ | TN3 ₂ | TN3 ₁ | TN3 ₀ | 19 |
| Scan Type Number 4 | ST4 ₁ | ST4 ₁ | ST4 ₁ | ST4 ₁ | ST4 ₂ | ST4 ₂ | ST4 ₂ | ST4 ₂ | 20 |
| Channel Set Number 4 | CS4 ₁₅ | CS4 ₁₄ | CS4 ₁₃ | CS4 ₁₂ | CS4 ₁₁ | CS4 ₁₀ | CS4 ₉ | CS4 ₈ | 21 |
| | CS4 ₇ | CS4 ₆ | CS4 ₅ | CS4 ₄ | CS4 ₃ | CS4 ₂ | CS4 ₁ | CS4 ₀ | 22 |
| Trace Number 4 | TN4 ₂₃ | TN4 ₂₂ | TN4 ₂₁ | TN4 ₂₀ | TN4 ₁₉ | TN4 ₁₈ | TN4 ₁₇ | TN4 ₁₆ | 23 |
| | TN4 ₁₅ | TN4 ₁₄ | TN4 ₁₃ | TN4 ₁₂ | TN4 ₁₁ | TN4 ₁₀ | TN4 ₉ | TN4 ₈ | 24 |
| | TN4 ₇ | TN4 ₆ | TN4 ₅ | TN4 ₄ | TN4 ₃ | TN4 ₂ | TN4 ₁ | TN4 ₀ | 25 |
| Scan Type Number 5 | ST5 ₁ | ST5 ₁ | ST5 ₁ | ST5 ₁ | ST5 ₂ | ST5 ₂ | ST5 ₂ | ST5 ₂ | 26 |
| Channel Set Number 5 | CS5 ₁₅ | CS5 ₁₄ | CS5 ₁₃ | CS5 ₁₂ | CS5 ₁₁ | CS5 ₁₀ | CS5 ₉ | CS5 ₈ | 27 |
| | CS5 ₇ | CS5 ₆ | CS5 ₅ | CS5 ₄ | CS5 ₃ | CS5 ₂ | CS5 ₁ | CS5 ₀ | 28 |
| Trace Number 5 | TN5 ₂₃ | TN5 ₂₂ | TN5 ₂₁ | TN5 ₂₀ | TN5 ₁₉ | TN5 ₁₈ | TN5 ₁₇ | TN5 ₁₆ | 29 |
| | TN5 ₁₅ | TN5 ₁₄ | TN5 ₁₃ | TN5 ₁₂ | TN5 ₁₁ | TN5 ₁₀ | TN5 ₉ | TN5 ₈ | 30 |
| | TN5 ₇ | TN5 ₆ | TN5 ₅ | TN5 ₄ | TN5 ₃ | TN5 ₂ | TN5 ₁ | TN5 ₀ | 31 |
| Header Block Type | 0 | 0 | 1 | 0 | 0 | 0 | 0 | 1 | 32 |

7.12 COORDINATE REFERENCE SYSTEM IDENTIFICATION (conditional)

This header block is mandatory if a position block is included in the record.

| Bit No. | 0 | 1 | 2 | 3 | 4 | 5 | 6 | 7 | |
|--------------------------------------------------|------|------|------|------|------|------|------|------|----|
| Coordinate Reference System (CRS) identification | CRID | CRID | CRID | CRID | CRID | CRID | CRID | CRID | 1 |
| | CRID | CRID | CRID | CRID | CRID | CRID | CRID | CRID | 2 |
| | CRID | CRID | CRID | CRID | CRID | CRID | CRID | CRID | 3 |
| | CRID | CRID | CRID | CRID | CRID | CRID | CRID | CRID | 4 |
| | CRID | CRID | CRID | CRID | CRID | CRID | CRID | CRID | 5 |
| | CRID | CRID | CRID | CRID | CRID | CRID | CRID | CRID | 6 |
| | CRID | CRID | CRID | CRID | CRID | CRID | CRID | CRID | 7 |
| | CRID | CRID | CRID | CRID | CRID | CRID | CRID | CRID | 8 |
| | CRID | CRID | CRID | CRID | CRID | CRID | CRID | CRID | 9 |
| | CRID | CRID | CRID | CRID | CRID | CRID | CRID | CRID | 10 |
| | CRID | CRID | CRID | CRID | CRID | CRID | CRID | CRID | 11 |
| | CRID | CRID | CRID | CRID | CRID | CRID | CRID | CRID | 12 |
| | CRID | CRID | CRID | CRID | CRID | CRID | CRID | CRID | 13 |
| | CRID | CRID | CRID | CRID | CRID | CRID | CRID | CRID | 14 |
| | CRID | CRID | CRID | CRID | CRID | CRID | CRID | CRID | 15 |
| | CRID | CRID | CRID | CRID | CRID | CRID | CRID | CRID | 16 |
| | CRID | CRID | CRID | CRID | CRID | CRID | CRID | CRID | 17 |
| | CRID | CRID | CRID | CRID | CRID | CRID | CRID | CRID | 18 |
| | CRID | CRID | CRID | CRID | CRID | CRID | CRID | CRID | 19 |
| | CRID | CRID | CRID | CRID | CRID | CRID | CRID | CRID | 20 |
| | CRID | CRID | CRID | CRID | CRID | CRID | CRID | CRID | 21 |
| | CRID | CRID | CRID | CRID | CRID | CRID | CRID | CRID | 22 |
| | CRID | CRID | CRID | CRID | CRID | CRID | CRID | CRID | 23 |
| | CRID | CRID | CRID | CRID | CRID | CRID | CRID | CRID | 24 |
| | CRID | CRID | CRID | CRID | CRID | CRID | CRID | CRID | 25 |
| | CRID | CRID | CRID | CRID | CRID | CRID | CRID | CRID | 26 |
| | CRID | CRID | CRID | CRID | CRID | CRID | CRID | CRID | 27 |
| | CRID | CRID | CRID | CRID | CRID | CRID | CRID | CRID | 28 |
| | CRID | CRID | CRID | CRID | CRID | CRID | CRID | CRID | 29 |
| | CRID | CRID | CRID | CRID | CRID | CRID | CRID | CRID | 30 |
| | CRID | CRID | CRID | CRID | CRID | CRID | CRID | CRID | 31 |
| Header Blk Type | 0 | 1 | 0 | 1 | 0 | 1 | 0 | 1 | 32 |

7.13 POSITION BLOCKS (optional)

| Bit No. | 0 | 1 | 2 | 3 | 4 | 5 | 6 | 7 | |
|------------------|------------------|------------------|------------------|------------------|------------------|------------------|------------------|------------------|---|
| Time of position | TP ₆₃ | TP ₆₂ | TP ₆₁ | TP ₆₀ | TP ₅₉ | TP ₅₈ | TP ₅₇ | TP ₅₆ | 1 |
| | TP ₅₅ | TP ₅₄ | TP ₅₃ | TP ₅₂ | TP ₅₁ | TP ₅₀ | TP ₄₉ | TP ₄₈ | 2 |
| | TP ₄₇ | TP ₄₆ | TP ₄₅ | TP ₄₄ | TP ₄₃ | TP ₄₂ | TP ₄₁ | TP ₄₀ | 3 |
| | TP ₃₉ | TP ₃₈ | TP ₃₇ | TP ₃₆ | TP ₃₅ | TP ₃₄ | TP ₃₃ | TP ₃₂ | 4 |
| | TP ₃₁ | TP ₃₀ | TP ₂₉ | TP ₂₈ | TP ₂₇ | TP ₂₆ | TP ₂₅ | TP ₂₄ | 5 |
| | TP ₂₃ | TP ₂₂ | TP ₂₁ | TP ₂₀ | TP ₁₉ | TP ₁₈ | TP ₁₇ | TP ₁₆ | 6 |
| | TP ₁₅ | TP ₁₄ | TP ₁₃ | TP ₁₂ | TP ₁₁ | TP ₁₀ | TP ₉ | TP ₈ | 7 |

| | | | | | | | | | |
|-----------------------------------------------------|-------------------|-------------------|-------------------|-------------------|-------------------|-------------------|-------------------|-------------------|----|
| | TP ₇ | TP ₆ | TP ₅ | TP ₄ | TP ₃ | TP ₂ | TP ₁ | TP ₀ | 8 |
| Time of measurement/ calculation | TC ₆₃ | TC ₆₂ | TC ₆₁ | TC ₆₀ | TC ₅₉ | TC ₅₈ | TC ₅₇ | TC ₅₆ | 9 |
| | TC ₅₅ | TC ₅₄ | TC ₅₃ | TC ₅₂ | TC ₅₁ | TC ₅₀ | TC ₄₉ | TC ₄₈ | 10 |
| | TC ₄₇ | TC ₄₆ | TC ₄₅ | TC ₄₄ | TC ₄₃ | TC ₄₂ | TC ₄₁ | TC ₄₀ | 11 |
| | TC ₃₉ | TC ₃₈ | TC ₃₇ | TC ₃₆ | TC ₃₅ | TC ₃₄ | TC ₃₃ | TC ₃₂ | 12 |
| | TC ₃₁ | TC ₃₀ | TC ₂₉ | TC ₂₈ | TC ₂₇ | TC ₂₆ | TC ₂₅ | TC ₂₄ | 13 |
| | TC ₂₃ | TC ₂₂ | TC ₂₁ | TC ₂₀ | TC ₁₉ | TC ₁₈ | TC ₁₇ | TC ₁₆ | 14 |
| | TC ₁₅ | TC ₁₄ | TC ₁₃ | TC ₁₂ | TC ₁₁ | TC ₁₀ | TC ₉ | TC ₈ | 15 |
| | TC ₇ | TC ₆ | TC ₅ | TC ₄ | TC ₃ | TC ₂ | TC ₁ | TC ₀ | 16 |
| Vertical error | VE ₃₁ | VE ₃₀ | VE ₂₉ | VE ₂₈ | VE ₂₇ | VE ₂₆ | VE ₂₅ | VE ₂₄ | 17 |
| | VE ₂₃ | VE ₂₂ | VE ₂₁ | VE ₂₀ | VE ₁₉ | VE ₁₈ | VE ₁₇ | VE ₁₆ | 18 |
| | VE ₁₅ | VE ₁₄ | VE ₁₃ | VE ₁₂ | VE ₁₁ | VE ₁₀ | VE ₉ | VE ₈ | 19 |
| | VE ₇ | VE ₆ | VE ₅ | VE ₄ | VE ₃ | VE ₂ | VE ₁ | VE ₀ | 20 |
| Horizontal error ellipse semi-major dimension | HEA ₃₁ | HEA ₃₀ | HEA ₂₉ | HEA ₂₈ | HEA ₂₇ | HEA ₂₆ | HEA ₂₅ | HEA ₂₄ | 21 |
| | HEA ₂₃ | HEA ₂₂ | HEA ₂₁ | HEA ₂₀ | HEA ₁₉ | HEA ₁₈ | HEA ₁₇ | HEA ₁₆ | 22 |
| | HEA ₁₅ | HEA ₁₄ | HEA ₁₃ | HEA ₁₂ | HEA ₁₁ | HEA ₁₀ | HEA ₉ | HEA ₈ | 23 |
| | HEA ₇ | HEA ₆ | HEA ₅ | HEA ₄ | HEA ₃ | HEA ₂ | HEA ₁ | HEA ₀ | 24 |
| Horizontal error ellipse semi-minor dimension | HEB ₃₁ | HEB ₃₀ | HEB ₂₉ | HEB ₂₈ | HEB ₂₇ | HEB ₂₆ | HEB ₂₅ | HEB ₂₄ | 25 |
| | HEB ₂₃ | HEB ₂₂ | HEB ₂₁ | HEB ₂₀ | HEB ₁₉ | HEB ₁₈ | HEB ₁₇ | HEB ₁₆ | 26 |
| | HEB ₁₅ | HEB ₁₄ | HEB ₁₃ | HEB ₁₂ | HEB ₁₁ | HEB ₁₀ | HEB ₉ | HEB ₈ | 27 |
| | HEB ₇ | HEB ₆ | HEB ₅ | HEB ₄ | HEB ₃ | HEB ₂ | HEB ₁ | HEB ₀ | 28 |
| Horizontal error ellipse orientation | HEO ₁₅ | HEO ₁₄ | HEO ₁₃ | HEO ₁₂ | HEO ₁₁ | HEO ₁₀ | HEO ₉ | HEO ₈ | 29 |
| | HEO ₇ | HEO ₆ | HEO ₅ | HEO ₄ | HEO ₃ | HEO ₂ | HEO ₁ | HEO ₀ | 30 |
| Position Type | PT ₇ | PT ₆ | PT ₅ | PT ₄ | PT ₃ | PT ₂ | PT ₁ | PT ₀ | 31 |
| Header Blk Type | 0 | 1 | 0 | 1 | 0 | 0 | 0 | 0 | 32 |

| | | | | | | | | | |
|--------------------------|--------------------|--------------------|--------------------|--------------------|--------------------|--------------------|--------------------|--------------------|----|
| Bit No. | 0 | 1 | 2 | 3 | 4 | 5 | 6 | 7 | |
| Coord tuple 1 Coord 1 | T1C1 ₆₃ | T1C1 ₆₂ | T1C1 ₆₁ | T1C1 ₆₀ | T1C1 ₅₉ | T1C1 ₅₈ | T1C1 ₅₇ | T1C1 ₅₆ | 33 |
| | T1C1 ₅₅ | T1C1 ₅₄ | T1C1 ₅₃ | T1C1 ₅₂ | T1C1 ₅₁ | T1C1 ₅₀ | T1C1 ₄₉ | T1C1 ₄₈ | 34 |
| | T1C1 ₄₇ | T1C1 ₄₆ | T1C1 ₄₅ | T1C1 ₄₄ | T1C1 ₄₃ | T1C1 ₄₂ | T1C1 ₄₁ | T1C1 ₄₀ | 35 |
| | T1C1 ₃₉ | T1C1 ₃₈ | T1C1 ₃₇ | T1C1 ₃₆ | T1C1 ₃₅ | T1C1 ₃₄ | T1C1 ₃₃ | T1C1 ₃₂ | 36 |
| | T1C1 ₃₁ | T1C1 ₃₀ | T1C1 ₂₉ | T1C1 ₂₈ | T1C1 ₂₇ | T1C1 ₂₆ | T1C1 ₂₅ | T1C1 ₂₄ | 37 |
| | T1C1 ₂₃ | T1C1 ₂₂ | T1C1 ₂₁ | T1C1 ₂₀ | T1C1 ₁₉ | T1C1 ₁₈ | T1C1 ₁₇ | T1C1 ₁₆ | 38 |
| | T1C1 ₁₅ | T1C1 ₁₄ | T1C1 ₁₃ | T1C1 ₁₂ | T1C1 ₁₁ | T1C1 ₁₀ | T1C1 ₉ | T1C1 ₈ | 39 |
| | T1C1 ₇ | T1C1 ₆ | T1C1 ₅ | T1C1 ₄ | T1C1 ₃ | T1C1 ₂ | T1C1 ₁ | T1C1 ₀ | 40 |
| Coord tuple 1 Coord 2 | T1C2 ₆₃ | T1C2 ₆₂ | T1C2 ₆₁ | T1C2 ₆₀ | T1C2 ₅₉ | T1C2 ₅₈ | T1C2 ₅₇ | T1C2 ₅₆ | 41 |
| | T1C2 ₅₅ | T1C2 ₅₄ | T1C2 ₅₃ | T1C2 ₅₂ | T1C2 ₅₁ | T1C2 ₅₀ | T1C2 ₄₉ | T1C2 ₄₈ | 42 |
| | T1C2 ₄₇ | T1C2 ₄₆ | T1C2 ₄₅ | T1C2 ₄₄ | T1C2 ₄₃ | T1C2 ₄₂ | T1C2 ₄₁ | T1C2 ₄₀ | 43 |
| | T1C2 ₃₉ | T1C2 ₃₈ | T1C2 ₃₇ | T1C2 ₃₆ | T1C2 ₃₅ | T1C2 ₃₄ | T1C2 ₃₃ | T1C2 ₃₂ | 44 |
| | T1C2 ₃₁ | T1C2 ₃₀ | T1C2 ₂₉ | T1C2 ₂₈ | T1C2 ₂₇ | T1C2 ₂₆ | T1C2 ₂₅ | T1C2 ₂₄ | 45 |
| | T1C2 ₂₃ | T1C2 ₂₂ | T1C2 ₂₁ | T1C2 ₂₀ | T1C2 ₁₉ | T1C2 ₁₈ | T1C2 ₁₇ | T1C2 ₁₆ | 46 |
| | T1C2 ₁₅ | T1C2 ₁₄ | T1C2 ₁₃ | T1C2 ₁₂ | T1C2 ₁₁ | T1C2 ₁₀ | T1C2 ₉ | T1C2 ₈ | 47 |
| | T1C2 ₇ | T1C2 ₆ | T1C2 ₅ | T1C2 ₄ | T1C2 ₃ | T1C2 ₂ | T1C2 ₁ | T1C2 ₀ | 48 |
| Coord tuple 1 Coord 3 | T1C3 ₆₃ | T1C3 ₆₂ | T1C3 ₆₁ | T1C3 ₆₀ | T1C3 ₅₉ | T1C3 ₅₈ | T1C3 ₅₇ | T1C3 ₅₆ | 49 |
| | T1C3 ₅₅ | T1C3 ₅₄ | T1C3 ₅₃ | T1C3 ₅₂ | T1C3 ₅₁ | T1C3 ₅₀ | T1C3 ₄₉ | T1C3 ₄₈ | 50 |
| | T1C3 ₄₇ | T1C3 ₄₆ | T1C3 ₄₅ | T1C3 ₄₄ | T1C3 ₄₃ | T1C3 ₄₂ | T1C3 ₄₁ | T1C3 ₄₀ | 51 |
| | T1C3 ₃₉ | T1C3 ₃₈ | T1C3 ₃₇ | T1C3 ₃₆ | T1C3 ₃₅ | T1C3 ₃₄ | T1C3 ₃₃ | T1C3 ₃₂ | 52 |
| | T1C3 ₃₁ | T1C3 ₃₀ | T1C3 ₂₉ | T1C3 ₂₈ | T1C3 ₂₇ | T1C3 ₂₆ | T1C3 ₂₅ | T1C3 ₂₄ | 53 |
| | T1C3 ₂₃ | T1C3 ₂₂ | T1C3 ₂₁ | T1C3 ₂₀ | T1C3 ₁₉ | T1C3 ₁₈ | T1C3 ₁₇ | T1C3 ₁₆ | 54 |

| | | | | | | | | | |
|--------------------|--------------------|--------------------|--------------------|--------------------|--------------------|--------------------|-------------------|-------------------|----|
| | T1C3 ₁₅ | T1C3 ₁₄ | T1C3 ₁₃ | T1C3 ₁₂ | T1C3 ₁₁ | T1C3 ₁₀ | T1C3 ₉ | T1C3 ₈ | 55 |
| | T1C3 ₇ | T1C3 ₆ | T1C3 ₅ | T1C3 ₄ | T1C3 ₃ | T1C3 ₂ | T1C3 ₁ | T1C3 ₀ | 56 |
| Stanza ID 1 | ID1 ₁₅ | ID1 ₁₄ | ID1 ₁₃ | ID1 ₁₂ | ID1 ₁₁ | ID1 ₁₀ | ID1 ₉ | ID1 ₈ | 57 |
| | ID1 ₇ | ID1 ₆ | ID1 ₅ | ID1 ₄ | ID1 ₃ | ID1 ₂ | ID1 ₁ | ID1 ₀ | 58 |
| Position 1 valid | PV1 ₇ | PV1 ₆ | PV1 ₅ | PV1 ₄ | PV1 ₃ | PV1 ₂ | PV1 ₁ | PV1 ₀ | 59 |
| Position 1 quality | PQ1 ₇ | PQ1 ₆ | PQ1 ₅ | PQ1 ₄ | PQ1 ₃ | PQ1 ₂ | PQ1 ₁ | PQ1 ₀ | 60 |
| Undefined | X | X | X | X | X | X | X | X | 61 |
| | X | X | X | X | X | X | X | X | 62 |
| | X | X | X | X | X | X | X | X | 63 |
| Header Blk Type | 0 | 1 | 0 | 1 | 0 | 0 | 0 | 1 | 64 |

| Bit No. | 0 | 1 | 2 | 3 | 4 | 5 | 6 | 7 | |
|--------------------------|--------------------|--------------------|--------------------|--------------------|--------------------|--------------------|--------------------|--------------------|----|
| Coord tuple 2 Coord 1 | T2C1 ₆₃ | T2C1 ₆₂ | T2C1 ₆₁ | T2C1 ₆₀ | T2C1 ₅₉ | T2C1 ₅₈ | T2C1 ₅₇ | T2C1 ₅₆ | 65 |
| | T2C1 ₅₅ | T2C1 ₅₄ | T2C1 ₅₃ | T2C1 ₅₂ | T2C1 ₅₁ | T2C1 ₅₀ | T2C1 ₄₉ | T2C1 ₄₈ | 66 |
| | T2C1 ₄₇ | T2C1 ₄₆ | T2C1 ₄₅ | T2C1 ₄₄ | T2C1 ₄₃ | T2C1 ₄₂ | T2C1 ₄₁ | T2C1 ₄₀ | 67 |
| | T2C1 ₃₉ | T2C1 ₃₈ | T2C1 ₃₇ | T2C1 ₃₆ | T2C1 ₃₅ | T2C1 ₃₄ | T2C1 ₃₃ | T2C1 ₃₂ | 68 |
| | T2C1 ₃₁ | T2C1 ₃₀ | T2C1 ₂₉ | T2C1 ₂₈ | T2C1 ₂₇ | T2C1 ₂₆ | T2C1 ₂₅ | T2C1 ₂₄ | 69 |
| | T2C1 ₂₃ | T2C1 ₂₂ | T2C1 ₂₁ | T2C1 ₂₀ | T2C1 ₁₉ | T2C1 ₁₈ | T2C1 ₁₇ | T2C1 ₁₆ | 70 |
| | T2C1 ₁₅ | T2C1 ₁₄ | T2C1 ₁₃ | T2C1 ₁₂ | T2C1 ₁₁ | T2C1 ₁₀ | T2C1 ₉ | T2C1 ₈ | 71 |
| | T2C1 ₇ | T2C1 ₆ | T2C1 ₅ | T2C1 ₄ | T2C1 ₃ | T2C1 ₂ | T2C1 ₁ | T2C1 ₀ | 72 |
| Coord tuple 2 Coord 2 | T2C2 ₆₃ | T2C2 ₆₂ | T2C2 ₆₁ | T2C2 ₆₀ | T2C2 ₅₉ | T2C2 ₅₈ | T2C2 ₅₇ | T2C2 ₅₆ | 73 |
| | T2C2 ₅₅ | T2C2 ₅₄ | T2C2 ₅₃ | T2C2 ₅₂ | T2C2 ₅₁ | T2C2 ₅₀ | T2C2 ₄₉ | T2C2 ₄₈ | 74 |
| | T2C2 ₄₇ | T2C2 ₄₆ | T2C2 ₄₅ | T2C2 ₄₄ | T2C2 ₄₃ | T2C2 ₄₂ | T2C2 ₄₁ | T2C2 ₄₀ | 75 |
| | T2C2 ₃₉ | T2C2 ₃₈ | T2C2 ₃₇ | T2C2 ₃₆ | T2C2 ₃₅ | T2C2 ₃₄ | T2C2 ₃₃ | T2C2 ₃₂ | 76 |
| | T2C2 ₃₁ | T2C2 ₃₀ | T2C2 ₂₉ | T2C2 ₂₈ | T2C2 ₂₇ | T2C2 ₂₆ | T2C2 ₂₅ | T2C2 ₂₄ | 77 |
| | T2C2 ₂₃ | T2C2 ₂₂ | T2C2 ₂₁ | T2C2 ₂₀ | T2C2 ₁₉ | T2C2 ₁₈ | T2C2 ₁₇ | T2C2 ₁₆ | 78 |
| | T2C2 ₁₅ | T2C2 ₁₄ | T2C2 ₁₃ | T2C2 ₁₂ | T2C2 ₁₁ | T2C2 ₁₀ | T2C2 ₉ | T2C2 ₈ | 79 |
| | T2C2 ₇ | T2C2 ₆ | T2C2 ₅ | T2C2 ₄ | T2C2 ₃ | T2C2 ₂ | T2C2 ₁ | T2C2 ₀ | 80 |
| Coord tuple 2 Coord 3 | T2C3 ₆₃ | T2C3 ₆₂ | T2C3 ₆₁ | T2C3 ₆₀ | T2C3 ₅₉ | T2C3 ₅₈ | T2C3 ₅₇ | T2C3 ₅₆ | 81 |
| | T2C3 ₅₅ | T2C3 ₅₄ | T2C3 ₅₃ | T2C3 ₅₂ | T2C3 ₅₁ | T2C3 ₅₀ | T2C3 ₄₉ | T2C3 ₄₈ | 82 |
| | T2C3 ₄₇ | T2C3 ₄₆ | T2C3 ₄₅ | T2C3 ₄₄ | T2C3 ₄₃ | T2C3 ₄₂ | T2C3 ₄₁ | T2C3 ₄₀ | 83 |
| | T2C3 ₃₉ | T2C3 ₃₈ | T2C3 ₃₇ | T2C3 ₃₆ | T2C3 ₃₅ | T2C3 ₃₄ | T2C3 ₃₃ | T2C3 ₃₂ | 84 |
| | T2C3 ₃₁ | T2C3 ₃₀ | T2C3 ₂₉ | T2C3 ₂₈ | T2C3 ₂₇ | T2C3 ₂₆ | T2C3 ₂₅ | T2C3 ₂₄ | 85 |
| | T2C3 ₂₃ | T2C3 ₂₂ | T2C3 ₂₁ | T2C3 ₂₀ | T2C3 ₁₉ | T2C3 ₁₈ | T2C3 ₁₇ | T2C3 ₁₆ | 86 |
| | T2C3 ₁₅ | T2C3 ₁₄ | T2C3 ₁₃ | T2C3 ₁₂ | T2C3 ₁₁ | T2C3 ₁₀ | T2C3 ₉ | T2C3 ₈ | 87 |
| | T2C3 ₇ | T2C3 ₆ | T2C3 ₅ | T2C3 ₄ | T2C3 ₃ | T2C3 ₂ | T2C3 ₁ | T2C3 ₀ | 88 |
| Stanza ID 2 | ID2 ₁₅ | ID2 ₁₄ | ID2 ₁₃ | ID2 ₁₂ | ID2 ₁₁ | ID2 ₁₀ | ID2 ₉ | ID2 ₈ | 89 |
| | ID2 ₇ | ID2 ₆ | ID2 ₅ | ID2 ₄ | ID2 ₃ | ID2 ₂ | ID2 ₁ | ID2 ₀ | 90 |
| Position 2 valid | PV2 ₇ | PV2 ₆ | PV2 ₅ | PV2 ₄ | PV2 ₃ | PV2 ₂ | PV2 ₁ | PV2 ₀ | 91 |
| Position 2 quality | PQ2 ₇ | PQ2 ₆ | PQ2 ₅ | PQ2 ₄ | PQ2 ₃ | PQ2 ₂ | PQ2 ₁ | PQ2 ₀ | 92 |
| Undefined | X | X | X | X | X | X | X | X | 93 |
| | X | X | X | X | X | X | X | X | 94 |
| | X | X | X | X | X | X | X | X | 95 |
| Header Blk Type | 0 | 1 | 0 | 1 | 0 | 0 | 1 | 0 | 96 |

7.14 RELATIVE POSITION BLOCK (optional)

| Bit No. | 0 | 1 | 2 | 3 | 4 | 5 | 6 | 7 | |
|-----------------|------------------|------------------|------------------|------------------|------------------|------------------|------------------|------------------|----|
| Offset easting | OE ₃₁ | OE ₃₀ | OE ₂₉ | OE ₂₈ | OE ₂₇ | OE ₂₆ | OE ₂₅ | OE ₂₄ | 1 |
| | OE ₂₃ | OE ₂₂ | OE ₂₁ | OE ₂₀ | OE ₁₉ | OE ₁₈ | OE ₁₇ | OE ₁₆ | 2 |
| | OE ₁₅ | OE ₁₄ | OE ₁₃ | OE ₁₂ | OE ₁₁ | OE ₁₀ | OE ₉ | OE ₈ | 3 |
| | OE ₇ | OE ₆ | OE ₅ | OE ₄ | OE ₃ | OE ₂ | OE ₁ | OE ₀ | 4 |
| Offset northing | ON ₃₁ | ON ₃₀ | ON ₂₉ | ON ₂₈ | ON ₂₇ | ON ₂₆ | ON ₂₅ | ON ₂₄ | 5 |
| | ON ₂₃ | ON ₂₂ | ON ₂₁ | ON ₂₀ | ON ₁₉ | ON ₁₈ | ON ₁₇ | ON ₁₆ | 6 |
| | ON ₁₅ | ON ₁₄ | ON ₁₃ | ON ₁₂ | ON ₁₁ | ON ₁₀ | ON ₉ | ON ₈ | 7 |
| | ON ₇ | ON ₆ | ON ₅ | ON ₄ | ON ₃ | ON ₂ | ON ₁ | ON ₀ | 8 |
| Offset vertical | OD ₃₁ | OD ₃₀ | OD ₂₉ | OD ₂₈ | OD ₂₇ | OD ₂₆ | OD ₂₅ | OD ₂₄ | 9 |
| | OD ₂₃ | OD ₂₂ | OD ₂₁ | OD ₂₀ | OD ₁₉ | OD ₁₈ | OD ₁₇ | OD ₁₆ | 10 |
| | OD ₁₅ | OD ₁₄ | OD ₁₃ | OD ₁₂ | OD ₁₁ | OD ₁₀ | OD ₉ | OD ₈ | 11 |
| | OD ₇ | OD ₆ | OD ₅ | OD ₄ | OD ₃ | OD ₂ | OD ₁ | OD ₀ | 12 |
| Description | DE | DE | DE | DE | DE | DE | DE | DE | 13 |
| | DE | DE | DE | DE | DE | DE | DE | DE | 14 |
| | DE | DE | DE | DE | DE | DE | DE | DE | 15 |
| | DE | DE | DE | DE | DE | DE | DE | DE | 16 |
| | DE | DE | DE | DE | DE | DE | DE | DE | 17 |
| | DE | DE | DE | DE | DE | DE | DE | DE | 18 |
| | DE | DE | DE | DE | DE | DE | DE | DE | 19 |
| | DE | DE | DE | DE | DE | DE | DE | DE | 20 |
| | DE | DE | DE | DE | DE | DE | DE | DE | 21 |
| | DE | DE | DE | DE | DE | DE | DE | DE | 22 |
| | DE | DE | DE | DE | DE | DE | DE | DE | 23 |
| | DE | DE | DE | DE | DE | DE | DE | DE | 24 |
| | DE | DE | DE | DE | DE | DE | DE | DE | 25 |
| | DE | DE | DE | DE | DE | DE | DE | DE | 26 |
| | DE | DE | DE | DE | DE | DE | DE | DE | 27 |
| | DE | DE | DE | DE | DE | DE | DE | DE | 28 |
| | DE | DE | DE | DE | DE | DE | DE | DE | 29 |
| | DE | DE | DE | DE | DE | DE | DE | DE | 30 |
| DE | DE | DE | DE | DE | DE | DE | DE | 31 | |
| Header Blk Type | 0 | 1 | 0 | 1 | 0 | 1 | 1 | 0 | 32 |

7.15 SCAN TYPE HEADER (Channel Set Descriptor)

| Bit No. | 0 | 1 | 2 | 3 | 4 | 5 | 6 | 7 | |
|------------------|-----------------|-----------------|-----------------|-----------------|-----------------|-----------------|-----------------|-----------------|---|
| BCD Value MSD | 8 | 4 | 2 | 1 | 8 | 4 | 2 | 1 | |
| Binary Value MSB | 128 | 64 | 32 | 16 | 8 | 4 | 2 | 1 | |
| Scan Type No. | ST ₁ | ST ₁ | ST ₁ | ST ₁ | ST ₂ | ST ₂ | ST ₂ | ST ₂ | 1 |

| | | | | | | | | | |
|-----------------------------------|-------------------|-------------------|-------------------|-------------------|-------------------|-------------------|-------------------|-------------------|----|
| Channel Set No. | CS ₁₅ | CS ₁₄ | CS ₁₃ | CS ₁₂ | CS ₁₁ | CS ₁₀ | CS ₉ | CS ₈ | 2 |
| Channel Type | CS ₇ | CS ₆ | CS ₅ | CS ₄ | CS ₃ | CS ₂ | CS ₁ | CS ₀ | 3 |
| | C ₇ | C ₆ | C ₅ | C ₄ | C ₃ | C ₂ | C ₁ | C ₀ | 4 |
| Channel Set Start Time | TF ₃₁ | TF ₃₀ | TF ₂₉ | TF ₂₈ | TF ₂₇ | TF ₂₆ | TF ₂₅ | TF ₂₄ | 5 |
| | TF ₂₃ | TF ₂₂ | TF ₂₁ | TF ₂₀ | TF ₁₉ | TF ₁₈ | TF ₁₇ | TF ₁₆ | 6 |
| | TF ₁₅ | TF ₁₄ | TF ₁₃ | TF ₁₂ | TF ₁₁ | TF ₁₀ | TF ₉ | TF ₈ | 7 |
| | TF ₇ | TF ₆ | TF ₅ | TF ₄ | TF ₃ | TF ₂ | TF ₁ | TF ₀ | 8 |
| Channel Set End Time | TE ₃₁ | TE ₃₀ | TE ₂₉ | TE ₂₈ | TE ₂₇ | TE ₂₆ | TE ₂₅ | TE ₂₄ | 9 |
| | TE ₂₃ | TE ₂₂ | TE ₂₁ | TE ₂₀ | TE ₁₉ | TE ₁₈ | TE ₁₇ | TE ₁₆ | 10 |
| | TE ₁₅ | TE ₁₄ | TE ₁₃ | TE ₁₂ | TE ₁₁ | TE ₁₀ | TE ₉ | TE ₈ | 11 |
| | TE ₇ | TE ₆ | TE ₅ | TE ₄ | TE ₃ | TE ₂ | TE ₁ | TE ₀ | 12 |
| Number of Samples | NS ₃₁ | NS ₃₀ | NS ₂₉ | NS ₂₈ | NS ₂₇ | NS ₂₆ | NS ₂₅ | NS ₂₄ | 13 |
| | NS ₂₃ | NS ₂₂ | NS ₂₁ | NS ₂₀ | NS ₁₉ | NS ₁₈ | NS ₁₇ | NS ₁₆ | 14 |
| | NS ₁₅ | NS ₁₄ | NS ₁₃ | NS ₁₂ | NS ₁₁ | NS ₁₀ | NS ₉ | NS ₈ | 15 |
| | NS ₇ | NS ₆ | NS ₅ | NS ₄ | NS ₃ | NS ₂ | NS ₁ | NS ₀ | 16 |
| Descale Multiplier | DSM ₃₁ | DSM ₃₀ | DSM ₂₉ | DSM ₂₈ | DSM ₂₇ | DSM ₂₆ | DSM ₂₅ | DSM ₂₄ | 17 |
| | DSM ₂₃ | DSM ₂₂ | DSM ₂₁ | DSM ₂₀ | DSM ₁₉ | DSM ₁₈ | DSM ₁₇ | DSM ₁₆ | 18 |
| | DSM ₁₅ | DSM ₁₄ | DSM ₁₃ | DSM ₁₂ | DSM ₁₁ | DSM ₁₀ | DSM ₉ | DSM ₈ | 19 |
| | DSM ₇ | DSM ₆ | DSM ₅ | DSM ₄ | DSM ₃ | DSM ₂ | DSM ₁ | DSM ₀ | 20 |
| No. of Channels | C/S ₂₃ | C/S ₂₂ | C/S ₂₁ | C/S ₂₀ | C/S ₁₉ | C/S ₁₈ | C/S ₁₇ | C/S ₁₆ | 21 |
| | C/S ₁₅ | C/S ₁₄ | C/S ₁₃ | C/S ₁₂ | C/S ₁₁ | C/S ₁₀ | C/S ₉ | C/S ₈ | 22 |
| | C/S ₇ | C/S ₆ | C/S ₅ | C/S ₄ | C/S ₃ | C/S ₂ | C/S ₁ | C/S ₀ | 23 |
| Sampling Interval | SR ₂₃ | SR ₂₂ | SR ₂₁ | SR ₂₀ | SR ₁₉ | SR ₁₈ | SR ₁₇ | SR ₁₆ | 24 |
| | SR ₁₅ | SR ₁₄ | SR ₁₃ | SR ₁₂ | SR ₁₁ | SR ₁₀ | SR ₉ | SR ₈ | 25 |
| | SR ₇ | SR ₆ | SR ₅ | SR ₄ | SR ₃ | SR ₂ | SR ₁ | SR ₀ | 26 |
| Array Forming | ARY ₇ | ARY ₆ | ARY ₅ | ARY ₄ | ARY ₃ | ARY ₂ | ARY ₁ | ARY ₀ | 27 |
| Trace Header Extensions | THE ₇ | THE ₆ | THE ₅ | THE ₄ | THE ₃ | THE ₂ | THE ₁ | THE ₀ | 28 |
| Extended Header Flag/Channel Gain | EFH ₃ | EFH ₂ | EFH ₁ | EFH ₀ | J | J | J | J | 29 |
| Vertical Stack | VS ₇ | VS ₆ | VS ₅ | VS ₄ | VS ₃ | VS ₂ | VS ₁ | VS ₀ | 30 |
| Streamer No. | CAB ₇ | CAB ₆ | CAB ₅ | CAB ₄ | CAB ₃ | CAB ₂ | CAB ₁ | CAB ₀ | 31 |
| Header Block Type | 0 | 0 | 1 | 1 | 0 | 0 | 0 | 0 | 32 |

| | | | | | | | | | |
|------------------------|------------------|------------------|------------------|------------------|------------------|------------------|------------------|------------------|----|
| Bit No. | 0 | 1 | 2 | 3 | 4 | 5 | 6 | 7 | |
| BCD Value MSD | 8 | 4 | 2 | 1 | 8 | 4 | 2 | 1 | |
| Binary Value MSB | 128 | 64 | 32 | 16 | 8 | 4 | 2 | 1 | |
| Alias Filter Frequency | AF ₃₁ | AF ₃₀ | AF ₂₉ | AF ₂₈ | AF ₂₇ | AF ₂₆ | AF ₂₅ | AF ₂₄ | 33 |
| | AF ₂₃ | AF ₂₂ | AF ₂₁ | AF ₂₀ | AF ₁₉ | AF ₁₈ | AF ₁₇ | AF ₁₆ | 34 |
| | AF ₁₅ | AF ₁₄ | AF ₁₃ | AF ₁₂ | AF ₁₁ | AF ₁₀ | AF ₉ | AF ₈ | 35 |
| | AF ₇ | AF ₆ | AF ₅ | AF ₄ | AF ₃ | AF ₂ | AF ₁ | AF ₀ | 36 |
| Low Cut Filter | LC ₃₁ | LC ₃₀ | LC ₂₉ | LC ₂₈ | LC ₂₇ | LC ₂₆ | LC ₂₅ | LC ₂₄ | 37 |
| | LC ₂₃ | LC ₂₂ | LC ₂₁ | LC ₂₀ | LC ₁₉ | LC ₁₈ | LC ₁₇ | LC ₁₆ | 38 |
| | LC ₁₅ | LC ₁₄ | LC ₁₃ | LC ₁₂ | LC ₁₁ | LC ₁₀ | LC ₉ | LC ₈ | 39 |
| | LC ₇ | LC ₆ | LC ₅ | LC ₄ | LC ₃ | LC ₂ | LC ₁ | LC ₀ | 40 |
| Alias Filter Slope | AS ₃₁ | AS ₃₀ | AS ₂₉ | AS ₂₈ | AS ₂₇ | AS ₂₆ | AS ₂₅ | AS ₂₄ | 41 |
| | AS ₂₃ | AS ₂₂ | AS ₂₁ | AS ₂₀ | AS ₁₉ | AS ₁₈ | AS ₁₇ | AS ₁₆ | 42 |
| | AS ₁₅ | AS ₁₄ | AS ₁₃ | AS ₁₂ | AS ₁₁ | AS ₁₀ | AS ₉ | AS ₈ | 43 |
| | AS ₇ | AS ₆ | AS ₅ | AS ₄ | AS ₃ | AS ₂ | AS ₁ | AS ₀ | 44 |

| | | | | | | | | | |
|----------------------|-------------------|-------------------|-------------------|-------------------|-------------------|-------------------|-------------------|-------------------|----|
| Low Cut Filter Slope | LS ₃₁ | LS ₃₀ | LS ₂₉ | LS ₂₈ | LS ₂₇ | LS ₂₆ | LS ₂₅ | LS ₂₄ | 45 |
| | LS ₂₃ | LS ₂₂ | LS ₂₁ | LS ₂₀ | LS ₁₉ | LS ₁₈ | LS ₁₇ | LS ₁₆ | 46 |
| | LS ₁₅ | LS ₁₄ | LS ₁₃ | LS ₁₂ | LS ₁₁ | LS ₁₀ | LS ₉ | LS ₈ | 47 |
| | LS ₇ | LS ₆ | LS ₅ | LS ₄ | LS ₃ | LS ₂ | LS ₁ | LS ₀ | 48 |
| First Notch Filter | NT1 ₃₁ | NT1 ₃₀ | NT1 ₂₉ | NT1 ₂₈ | NT1 ₂₇ | NT1 ₂₆ | NT1 ₂₅ | NT1 ₂₄ | 49 |
| | NT1 ₂₃ | NT1 ₂₂ | NT1 ₂₁ | NT1 ₂₀ | NT1 ₁₉ | NT1 ₁₈ | NT1 ₁₇ | NT1 ₁₆ | 50 |
| | NT1 ₁₅ | NT1 ₁₄ | NT1 ₁₃ | NT1 ₁₂ | NT1 ₁₁ | NT1 ₁₀ | NT1 ₉ | NT1 ₈ | 51 |
| | NT1 ₇ | NT1 ₆ | NT1 ₅ | NT1 ₄ | NT1 ₃ | NT1 ₂ | NT1 ₁ | NT1 ₀ | 52 |
| Second Notch Filter | NT2 ₃₁ | NT2 ₃₀ | NT2 ₂₉ | NT2 ₂₈ | NT2 ₂₇ | NT2 ₂₆ | NT2 ₂₅ | NT2 ₂₄ | 53 |
| | NT2 ₂₃ | NT2 ₂₂ | NT2 ₂₁ | NT2 ₂₀ | NT2 ₁₉ | NT2 ₁₈ | NT2 ₁₇ | NT2 ₁₆ | 54 |
| | NT2 ₁₅ | NT2 ₁₄ | NT2 ₁₃ | NT2 ₁₂ | NT2 ₁₁ | NT2 ₁₀ | NT2 ₉ | NT2 ₈ | 55 |
| | NT2 ₇ | NT2 ₆ | NT2 ₅ | NT2 ₄ | NT2 ₃ | NT2 ₂ | NT2 ₁ | NT2 ₀ | 56 |
| Third Notch Filter | NT3 ₃₁ | NT3 ₃₀ | NT3 ₂₉ | NT3 ₂₈ | NT3 ₂₇ | NT3 ₂₆ | NT3 ₂₅ | NT3 ₂₄ | 57 |
| | NT3 ₂₃ | NT3 ₂₂ | NT3 ₂₁ | NT3 ₂₀ | NT3 ₁₉ | NT3 ₁₈ | NT3 ₁₇ | NT3 ₁₆ | 58 |
| | NT3 ₁₅ | NT3 ₁₄ | NT3 ₁₃ | NT3 ₁₂ | NT3 ₁₁ | NT3 ₁₀ | NT3 ₉ | NT3 ₈ | 59 |
| | NT3 ₇ | NT3 ₆ | NT3 ₅ | NT3 ₄ | NT3 ₃ | NT3 ₂ | NT3 ₁ | NT3 ₀ | 60 |
| Filter Phase | FPH ₇ | FPH ₆ | FPH ₅ | FPH ₄ | FPH ₃ | FPH ₂ | FPH ₁ | FPH ₀ | 61 |
| Physical Unit | PHU ₇ | PHU ₆ | PHU ₅ | PHU ₄ | PHU ₃ | PHU ₂ | PHU ₁ | PHU ₀ | 62 |
| | X | X | X | X | X | X | X | X | 63 |
| Header Block Type | 0 | 0 | 1 | 1 | 0 | 0 | 0 | 1 | 64 |

| | | | | | | | | | |
|------------------|-------------------|-------------------|-------------------|-------------------|-------------------|-------------------|-------------------|-------------------|----|
| Bit No. | 0 | 1 | 2 | 3 | 4 | 5 | 6 | 7 | |
| BCD Value MSD | 8 | 4 | 2 | 1 | 8 | 4 | 2 | 1 | |
| Binary Value MSB | 128 | 64 | 32 | 16 | 8 | 4 | 2 | 1 | |
| Filter delay | FDL ₃₁ | FDL ₃₀ | FDL ₂₉ | FDL ₂₈ | FDL ₂₇ | FDL ₂₆ | FDL ₂₅ | FDL ₂₄ | 65 |
| | FDL ₂₃ | FDL ₂₂ | FDL ₂₁ | FDL ₂₀ | FDL ₁₉ | FDL ₁₈ | FDL ₁₇ | FDL ₁₆ | 66 |
| | FDL ₁₅ | FDL ₁₄ | FDL ₁₃ | FDL ₁₂ | FDL ₁₁ | FDL ₁₀ | FDL ₉ | FDL ₈ | 67 |
| | FDL ₇ | FDL ₆ | FDL ₅ | FDL ₄ | FDL ₃ | FDL ₂ | FDL ₁ | FDL ₀ | 68 |
| Description | DSC | DSC | DSC | DSC | DSC | DSC | DSC | DSC | 69 |
| | DSC | DSC | DSC | DSC | DSC | DSC | DSC | DSC | 70 |
| | DSC | DSC | DSC | DSC | DSC | DSC | DSC | DSC | 71 |
| | DSC | DSC | DSC | DSC | DSC | DSC | DSC | DSC | 72 |
| | DSC | DSC | DSC | DSC | DSC | DSC | DSC | DSC | 73 |
| | DSC | DSC | DSC | DSC | DSC | DSC | DSC | DSC | 74 |
| | DSC | DSC | DSC | DSC | DSC | DSC | DSC | DSC | 75 |
| | DSC | DSC | DSC | DSC | DSC | DSC | DSC | DSC | 76 |
| | DSC | DSC | DSC | DSC | DSC | DSC | DSC | DSC | 77 |
| | DSC | DSC | DSC | DSC | DSC | DSC | DSC | DSC | 78 |
| | DSC | DSC | DSC | DSC | DSC | DSC | DSC | DSC | 79 |
| | DSC | DSC | DSC | DSC | DSC | DSC | DSC | DSC | 80 |
| | DSC | DSC | DSC | DSC | DSC | DSC | DSC | DSC | 81 |
| | DSC | DSC | DSC | DSC | DSC | DSC | DSC | DSC | 82 |
| | DSC | DSC | DSC | DSC | DSC | DSC | DSC | DSC | 83 |
| | DSC | DSC | DSC | DSC | DSC | DSC | DSC | DSC | 84 |
| | DSC | DSC | DSC | DSC | DSC | DSC | DSC | DSC | 85 |
| DSC | DSC | DSC | DSC | DSC | DSC | DSC | DSC | 86 | |
| DSC | DSC | DSC | DSC | DSC | DSC | DSC | DSC | 87 | |
| DSC | DSC | DSC | DSC | DSC | DSC | DSC | DSC | 88 | |

| | | | | | | | | | |
|-------------------|-----|-----|-----|-----|-----|-----|-----|-----|----|
| | DSC | DSC | DSC | DSC | DSC | DSC | DSC | DSC | 89 |
| | DSC | DSC | DSC | DSC | DSC | DSC | DSC | DSC | 90 |
| | DSC | DSC | DSC | DSC | DSC | DSC | DSC | DSC | 91 |
| | DSC | DSC | DSC | DSC | DSC | DSC | DSC | DSC | 92 |
| | DSC | DSC | DSC | DSC | DSC | DSC | DSC | DSC | 93 |
| | DSC | DSC | DSC | DSC | DSC | DSC | DSC | DSC | 94 |
| | DSC | DSC | DSC | DSC | DSC | DSC | DSC | DSC | 95 |
| Header Block Type | 0 | 0 | 1 | 1 | 0 | 0 | 1 | 0 | 96 |

7.16 DEMUX TRACE HEADER

| Bit No. | 0 | 1 | 2 | 3 | 4 | 5 | 6 | 7 | |
|-----------------------------|-------------------|-------------------|-------------------|-------------------|-------------------|-------------------|-------------------|-------------------|----|
| File Number | F ₁ | F ₁ | F ₁ | F ₁ | F ₂ | F ₂ | F ₂ | F ₂ | 1 |
| | F ₃ | F ₃ | F ₃ | F ₃ | F ₄ | F ₄ | F ₄ | F ₄ | 2 |
| Scan Type Number | ST ₁ | ST ₁ | ST ₁ | ST ₁ | ST ₂ | ST ₂ | ST ₂ | ST ₂ | 3 |
| Channel Set Number | CN ₁ | CN ₁ | CN ₁ | CN ₁ | CN ₂ | CN ₂ | CN ₂ | CN ₂ | 4 |
| Trace Number | TN ₁ | TN ₁ | TN ₁ | TN ₁ | TN ₂ | TN ₂ | TN ₂ | TN ₂ | 5 |
| | TN ₃ | TN ₃ | TN ₃ | TN ₃ | TN ₄ | TN ₄ | TN ₄ | TN ₄ | 6 |
| First Timing Word | T ₁₅ | T ₁₄ | T ₁₃ | T ₁₂ | T ₁₁ | T ₁₀ | T ₉ | T ₈ | 7 |
| | T ₇ | T ₆ | T ₅ | T ₄ | T ₃ | T ₂ | T ₁ | T ₀ | 8 |
| | T ₋₁ | T ₋₂ | T ₋₃ | T ₋₄ | T ₋₅ | T ₋₆ | T ₋₇ | T ₋₈ | 9 |
| Trace Header Extension | THE ₇ | THE ₆ | THE ₅ | THE ₄ | THE ₃ | THE ₂ | THE ₁ | THE ₀ | 10 |
| Sample Skew | SSK ₋₁ | SSK ₋₂ | SSK ₋₃ | SSK ₋₄ | SSK ₋₅ | SSK ₋₆ | SSK ₋₇ | SSK ₋₈ | 11 |
| Trace Edit | TR ₇ | TR ₆ | TR ₅ | TR ₄ | TR ₃ | TR ₂ | TR ₁ | TR ₀ | 12 |
| Time Break Window | TW ₁₅ | TW ₁₄ | TW ₁₃ | TW ₁₂ | TW ₁₁ | TW ₁₀ | TW ₉ | TW ₈ | 13 |
| | TW ₇ | TW ₆ | TW ₅ | TW ₄ | TW ₃ | TW ₂ | TW ₁ | TW ₀ | 14 |
| | TW ₋₁ | TW ₋₂ | TW ₋₃ | TW ₋₄ | TW ₋₅ | TW ₋₆ | TW ₋₇ | TW ₋₈ | 15 |
| Extended Channel Set Number | EN ₁₅ | EN ₁₄ | EN ₁₃ | EN ₁₂ | EN ₁₁ | EN ₁₀ | EN ₉ | EN ₈ | 16 |
| | EN ₇ | EN ₆ | EN ₅ | EN ₄ | EN ₃ | EN ₂ | EN ₁ | EN ₀ | 17 |
| Extended File Number | EFN ₂₃ | EFN ₂₂ | EFN ₂₁ | EFN ₂₀ | EFN ₁₉ | EFN ₁₈ | EFN ₁₇ | EFN ₁₆ | 18 |
| | EFN ₁₅ | EFN ₁₄ | EFN ₁₃ | EFN ₁₂ | EFN ₁₁ | EFN ₁₀ | EFN ₉ | EFN ₈ | 19 |
| | EFN ₇ | EFN ₆ | EFN ₅ | EFN ₄ | EFN ₃ | EFN ₂ | EFN ₁ | EFN ₀ | 20 |

7.17 TRACE HEADER EXTENSION #1

| Bit No. | 0 | 1 | 2 | 3 | 4 | 5 | 6 | 7 | |
|-------------------------------|--------------------------------|---------------------------------|---------------------------------|---------------------------------|---------------------------------|---------------------------------|---------------------------------|---------------------------------|----|
| Receiver Line Number | RLN ₂₃ | RLN ₂₂ | RLN ₂₁ | RLN ₂₀ | RLN ₁₉ | RLN ₁₈ | RLN ₁₇ | RLN ₁₆ | 1 |
| | RLN ₁₅ | RLN ₁₄ | RLN ₁₃ | RLN ₁₂ | RLN ₁₁ | RLN ₁₀ | RLN ₉ | RLN ₈ | 2 |
| | RLN ₇ | RLN ₆ | RLN ₅ | RLN ₄ | RLN ₃ | RLN ₂ | RLN ₁ | RLN ₀ | 3 |
| Receiver Point Number | RPN ₂₃ | RPN ₂₂ | RPN ₂₁ | RPN ₂₀ | RPN ₁₉ | RPN ₁₈ | RPN ₁₇ | RPN ₁₆ | 4 |
| | RPN ₁₅ | RPN ₁₄ | RPN ₁₃ | RPN ₁₂ | RPN ₁₁ | RPN ₁₀ | RPN ₉ | RPN ₈ | 5 |
| | RPN ₇ | RPN ₆ | RPN ₅ | RPN ₄ | RPN ₃ | RPN ₂ | RPN ₁ | RPN ₀ | 6 |
| Receiver Point Index | RPI ₇ | RPI ₆ | RPI ₅ | RPI ₄ | RPI ₃ | RPI ₂ | RPI ₁ | RPI ₀ | 7 |
| Reshoot Index | RI ₇ | RI ₆ | RI ₅ | RI ₄ | RI ₃ | RI ₂ | RI ₁ | RI ₀ | 8 |
| Group Index | GI ₇ | GI ₆ | GI ₅ | GI ₄ | GI ₃ | GI ₂ | GI ₁ | GI ₀ | 9 |
| Depth Index | DI ₇ | DI ₆ | DI ₅ | DI ₄ | DI ₃ | DI ₂ | DI ₁ | DI ₀ | 10 |
| Extended Receiver Line Number | ERLN ₂₃ | ERLN ₂₂ | ERLN ₂₁ | ERLN ₂₀ | ERLN ₁₉ | ERLN ₁₈ | ERLN ₁₇ | ERLN ₁₆ | 11 |
| | ERLN ₁₅ | ERLN ₁₄ | ERLN ₁₃ | ERLN ₁₂ | ERLN ₁₁ | ERLN ₁₀ | ERLN ₉ | ERLN ₈ | 12 |
| | ERLN ₇ | ERLN ₆ | ERLN ₅ | ERLN ₄ | ERLN ₃ | ERLN ₂ | ERLN ₁ | ERLN ₀ | 13 |
| | ERLN ₋₁ | ERLN ₋₂ | ERLN ₋₃ | ERLN ₋₄ | ERLN ₋₅ | ERLN ₋₆ | ERLN ₋₇ | ERLN ₋₈ | 14 |
| | ERLN ₋₉ | ERLN ₋₁₀ | ERLN ₋₁₁ | ERLN ₋₁₂ | ERLN ₋₁₃ | ERLN ₋₁₄ | ERLN ₋₁₅ | ERLN ₋₁₆ | 15 |
| Extended Receiver Point # | ERP _N ₂₃ | ERP _N ₂₂ | ERP _N ₂₁ | ERP _N ₂₀ | ERP _N ₁₉ | ERP _N ₁₈ | ERP _N ₁₇ | ERP _N ₁₆ | 16 |
| | ERP _N ₁₅ | ERP _N ₁₄ | ERP _N ₁₃ | ERP _N ₁₂ | ERP _N ₁₁ | ERP _N ₁₀ | ERP _N ₉ | ERP _N ₈ | 17 |
| | ERP _N ₇ | ERP _N ₆ | ERP _N ₅ | ERP _N ₄ | ERP _N ₃ | ERP _N ₂ | ERP _N ₁ | ERP _N ₀ | 18 |
| | ERP _N ₋₁ | ERP _N ₋₂ | ERP _N ₋₃ | ERP _N ₋₄ | ERP _N ₋₅ | ERP _N ₋₆ | ERP _N ₋₇ | ERP _N ₋₈ | 19 |
| | ERP _N ₋₉ | ERP _N ₋₁₀ | ERP _N ₋₁₁ | ERP _N ₋₁₂ | ERP _N ₋₁₃ | ERP _N ₋₁₄ | ERP _N ₋₁₅ | ERP _N ₋₁₆ | 20 |
| Sensor Type | SEN ₇ | SEN ₆ | SEN ₅ | SEN ₄ | SEN ₃ | SEN ₂ | SEN ₁ | SEN ₀ | 21 |
| Extended Trace Number | ETN ₂₃ | ETN ₂₂ | ETN ₂₁ | ETN ₂₀ | ETN ₁₉ | ETN ₁₈ | ETN ₁₇ | ETN ₁₆ | 22 |
| | ETN ₁₅ | ETN ₁₄ | ETN ₁₃ | ETN ₁₂ | ETN ₁₁ | ETN ₁₀ | ETN ₉ | ETN ₈ | 23 |
| | ETN ₇ | ETN ₆ | ETN ₅ | ETN ₄ | ETN ₃ | ETN ₂ | ETN ₁ | ETN ₀ | 24 |
| # of Samples per Trace | NS ₃₁ | NS ₃₀ | NS ₂₉ | NS ₂₈ | NS ₂₇ | NS ₂₆ | NS ₂₅ | NS ₂₄ | 25 |
| | NS ₂₃ | NS ₂₂ | NS ₂₁ | NS ₂₀ | NS ₁₉ | NS ₁₈ | NS ₁₇ | NS ₁₆ | 26 |
| | NS ₁₅ | NS ₁₄ | NS ₁₃ | NS ₁₂ | NS ₁₁ | NS ₁₀ | NS ₉ | NS ₈ | 27 |
| | NS ₇ | NS ₆ | NS ₅ | NS ₄ | NS ₃ | NS ₂ | NS ₁ | NS ₀ | 28 |
| Sensor Moving | MV ₇ | MV ₆ | MV ₅ | MV ₄ | MV ₃ | MV ₂ | MV ₁ | MV ₀ | 29 |
| Undefined | X | X | X | X | X | X | X | X | 30 |
| Physical Unit | PHU ₇ | PHU ₆ | PHU ₅ | PHU ₄ | PHU ₃ | PHU ₂ | PHU ₁ | PHU ₀ | 31 |
| Header Blk Type | 0 | 1 | 0 | 0 | 0 | 0 | 0 | 0 | 32 |

7.18 SENSOR INFO HEADER EXTENSION (optional)

| Bit No. | 0 | 1 | 2 | 3 | 4 | 5 | 6 | 7 | |
|----------------------|-------------------|-------------------|-------------------|-------------------|-------------------|-------------------|-------------------|-------------------|---|
| Instrument Test Time | ITT ₆₃ | ITT ₆₂ | ITT ₆₁ | ITT ₆₀ | ITT ₅₉ | ITT ₅₈ | ITT ₅₇ | ITT ₅₆ | 1 |
| | ITT ₅₅ | ITT ₅₄ | ITT ₅₃ | ITT ₅₂ | ITT ₅₁ | ITT ₅₀ | ITT ₄₉ | ITT ₄₈ | 2 |
| | ITT ₄₇ | ITT ₄₆ | ITT ₄₅ | ITT ₄₄ | ITT ₄₃ | ITT ₄₂ | ITT ₄₁ | ITT ₄₀ | 3 |
| | ITT ₃₉ | ITT ₃₈ | ITT ₃₇ | ITT ₃₆ | ITT ₃₅ | ITT ₃₄ | ITT ₃₃ | ITT ₃₂ | 4 |
| | ITT ₃₁ | ITT ₃₀ | ITT ₂₉ | ITT ₂₈ | ITT ₂₇ | ITT ₂₆ | ITT ₂₅ | ITT ₂₄ | 5 |
| | ITT ₂₃ | ITT ₂₂ | ITT ₂₁ | ITT ₂₀ | ITT ₁₉ | ITT ₁₈ | ITT ₁₇ | ITT ₁₆ | 6 |
| | ITT ₁₅ | ITT ₁₄ | ITT ₁₃ | ITT ₁₂ | ITT ₁₁ | ITT ₁₀ | ITT ₉ | ITT ₈ | 7 |

| | | | | | | | | | |
|--------------------|-------------------|-------------------|-------------------|-------------------|-------------------|-------------------|-------------------|-------------------|----|
| | ITT ₇ | ITT ₆ | ITT ₅ | ITT ₄ | ITT ₃ | ITT ₂ | ITT ₁ | ITT ₀ | 8 |
| Sensor Sensitivity | STY ₃₁ | STY ₃₀ | STY ₂₉ | STY ₂₈ | STY ₂₇ | STY ₂₆ | STY ₂₅ | STY ₂₄ | 9 |
| | STY ₂₃ | STY ₂₂ | STY ₂₁ | STY ₂₀ | STY ₁₉ | STY ₁₈ | STY ₁₇ | STY ₁₆ | 10 |
| | STY ₁₅ | STY ₁₄ | STY ₁₃ | STY ₁₂ | STY ₁₁ | STY ₁₀ | STY ₉ | STY ₈ | 11 |
| | STY ₇ | STY ₆ | STY ₅ | STY ₄ | STY ₃ | STY ₂ | STY ₁ | STY ₀ | 12 |
| Instr Test Result | ITR ₇ | ITR ₆ | ITR ₅ | ITR ₄ | ITR ₃ | ITR ₂ | ITR ₁ | ITR ₀ | 13 |
| Serial Number | SN | SN | SN | SN | SN | SN | SN | SN | 14 |
| | SN | SN | SN | SN | SN | SN | SN | SN | 15 |
| | SN | SN | SN | SN | SN | SN | SN | SN | 16 |
| | SN | SN | SN | SN | SN | SN | SN | SN | 17 |
| | SN | SN | SN | SN | SN | SN | SN | SN | 18 |
| | SN | SN | SN | SN | SN | SN | SN | SN | 19 |
| | SN | SN | SN | SN | SN | SN | SN | SN | 20 |
| | SN | SN | SN | SN | SN | SN | SN | SN | 21 |
| | SN | SN | SN | SN | SN | SN | SN | SN | 22 |
| | SN | SN | SN | SN | SN | SN | SN | SN | 23 |
| | SN | SN | SN | SN | SN | SN | SN | SN | 24 |
| | SN | SN | SN | SN | SN | SN | SN | SN | 25 |
| | SN | SN | SN | SN | SN | SN | SN | SN | 26 |
| | SN | SN | SN | SN | SN | SN | SN | SN | 27 |
| SN | SN | SN | SN | SN | SN | SN | SN | 28 | |
| SN | SN | SN | SN | SN | SN | SN | SN | 29 | |
| SN | SN | SN | SN | SN | SN | SN | SN | 30 | |
| SN | SN | SN | SN | SN | SN | SN | SN | 31 | |
| Header Blk Type | 0 | 1 | 0 | 0 | 0 | 0 | 0 | 1 | 32 |

7.19 TIMESTAMP HEADER (optional)

| Bit No. | 0 | 1 | 2 | 3 | 4 | 5 | 6 | 7 | |
|-------------------|-------------------|-------------------|-------------------|-------------------|-------------------|-------------------|-------------------|-------------------|----|
| Time Zero of Data | TZD ₆₃ | TZD ₆₂ | TZD ₆₁ | TZD ₆₀ | TZD ₅₉ | TZD ₅₈ | TZD ₅₇ | TZD ₅₆ | 1 |
| | TZD ₅₅ | TZD ₅₄ | TZD ₅₃ | TZD ₅₂ | TZD ₅₁ | TZD ₅₀ | TZD ₄₉ | TZD ₄₈ | 2 |
| | TZD ₄₇ | TZD ₄₆ | TZD ₄₅ | TZD ₄₄ | TZD ₄₃ | TZD ₄₂ | TZD ₄₁ | TZD ₄₀ | 3 |
| | TZD ₃₉ | TZD ₃₈ | TZD ₃₇ | TZD ₃₆ | TZD ₃₅ | TZD ₃₄ | TZD ₃₃ | TZD ₃₂ | 4 |
| | TZD ₃₁ | TZD ₃₀ | TZD ₂₉ | TZD ₂₈ | TZD ₂₇ | TZD ₂₆ | TZD ₂₅ | TZD ₂₄ | 5 |
| | TZD ₂₃ | TZD ₂₂ | TZD ₂₁ | TZD ₂₀ | TZD ₁₉ | TZD ₁₈ | TZD ₁₇ | TZD ₁₆ | 6 |
| | TZD ₁₅ | TZD ₁₄ | TZD ₁₃ | TZD ₁₂ | TZD ₁₁ | TZD ₁₀ | TZD ₉ | TZD ₈ | 7 |
| | TZD ₇ | TZD ₆ | TZD ₅ | TZD ₄ | TZD ₃ | TZD ₂ | TZD ₁ | TZD ₀ | 8 |
| Undefined | X | X | X | X | X | X | X | X | 9 |
| | X | X | X | X | X | X | X | X | 10 |
| | X | X | X | X | X | X | X | X | 11 |
| | X | X | X | X | X | X | X | X | 12 |
| | X | X | X | X | X | X | X | X | 13 |
| | X | X | X | X | X | X | X | X | 14 |
| | X | X | X | X | X | X | X | X | 15 |
| | X | X | X | X | X | X | X | X | 16 |
| | X | X | X | X | X | X | X | X | 17 |
| | X | X | X | X | X | X | X | X | 18 |
| | X | X | X | X | X | X | X | X | 19 |

| | | | | | | | | | |
|-----------------|---|---|---|---|---|---|---|---|----|
| | X | X | X | X | X | X | X | X | 20 |
| | X | X | X | X | X | X | X | X | 21 |
| | X | X | X | X | X | X | X | X | 22 |
| | X | X | X | X | X | X | X | X | 23 |
| | X | X | X | X | X | X | X | X | 24 |
| | X | X | X | X | X | X | X | X | 25 |
| | X | X | X | X | X | X | X | X | 26 |
| | X | X | X | X | X | X | X | X | 27 |
| | X | X | X | X | X | X | X | X | 28 |
| | X | X | X | X | X | X | X | X | 29 |
| | X | X | X | X | X | X | X | X | 30 |
| | X | X | X | X | X | X | X | X | 31 |
| Header Blk Type | 0 | 1 | 0 | 0 | 0 | 0 | 1 | 0 | 32 |

7.20 SENSOR CALIBRATION HEADER (optional)

| Bit No. | 0 | 1 | 2 | 3 | 4 | 5 | 6 | 7 | |
|---------------------|-------------------|-------------------|-------------------|-------------------|-------------------|-------------------|-------------------|-------------------|----|
| Frequency 1 | FR1 ₃₁ | FR1 ₃₀ | FR1 ₂₉ | FR1 ₂₈ | FR1 ₂₇ | FR1 ₂₆ | FR1 ₂₅ | FR1 ₂₄ | 1 |
| | FR1 ₂₃ | FR1 ₂₂ | FR1 ₂₁ | FR1 ₂₀ | FR1 ₁₉ | FR1 ₁₈ | FR1 ₁₇ | FR1 ₁₆ | 2 |
| | FR1 ₁₅ | FR1 ₁₄ | FR1 ₁₃ | FR1 ₁₂ | FR1 ₁₁ | FR1 ₁₀ | FR1 ₉ | FR1 ₈ | 3 |
| | FR1 ₇ | FR1 ₆ | FR1 ₅ | FR1 ₄ | FR1 ₃ | FR1 ₂ | FR1 ₁ | FR1 ₀ | 4 |
| Amplitude 1 | AM1 ₃₁ | AM1 ₃₀ | AM1 ₂₉ | AM1 ₂₈ | AM1 ₂₇ | AM1 ₂₆ | AM1 ₂₅ | AM1 ₂₄ | 5 |
| | AM1 ₂₃ | AM1 ₂₂ | AM1 ₂₁ | AM1 ₂₀ | AM1 ₁₉ | AM1 ₁₈ | AM1 ₁₇ | AM1 ₁₆ | 6 |
| | AM1 ₁₅ | AM1 ₁₄ | AM1 ₁₃ | AM1 ₁₂ | AM1 ₁₁ | AM1 ₁₀ | AM1 ₉ | AM1 ₈ | 7 |
| | AM1 ₇ | AM1 ₆ | AM1 ₅ | AM1 ₄ | AM1 ₃ | AM1 ₂ | AM1 ₁ | AM1 ₀ | 8 |
| Phase 1 | PH1 ₃₁ | PH1 ₃₀ | PH1 ₂₉ | PH1 ₂₈ | PH1 ₂₇ | PH1 ₂₆ | PH1 ₂₅ | PH1 ₂₄ | 9 |
| | PH1 ₂₃ | PH1 ₂₂ | PH1 ₂₁ | PH1 ₂₀ | PH1 ₁₉ | PH1 ₁₈ | PH1 ₁₇ | PH1 ₁₆ | 10 |
| | PH1 ₁₅ | PH1 ₁₄ | PH1 ₁₃ | PH1 ₁₂ | PH1 ₁₁ | PH1 ₁₀ | PH1 ₉ | PH1 ₈ | 11 |
| | PH1 ₇ | PH1 ₆ | PH1 ₅ | PH1 ₄ | PH1 ₃ | PH1 ₂ | PH1 ₁ | PH1 ₀ | 12 |
| Frequency 2 | FR2 ₃₁ | FR2 ₃₀ | FR2 ₂₉ | FR2 ₂₈ | FR2 ₂₇ | FR2 ₂₆ | FR2 ₂₅ | FR2 ₂₄ | 13 |
| | FR2 ₂₃ | FR2 ₂₂ | FR2 ₂₁ | FR2 ₂₀ | FR2 ₁₉ | FR2 ₁₈ | FR2 ₁₇ | FR2 ₁₆ | 14 |
| | FR2 ₁₅ | FR2 ₁₄ | FR2 ₁₃ | FR2 ₁₂ | FR2 ₁₁ | FR2 ₁₀ | FR2 ₉ | FR2 ₈ | 15 |
| | FR2 ₇ | FR2 ₆ | FR2 ₅ | FR2 ₄ | FR2 ₃ | FR2 ₂ | FR2 ₁ | FR2 ₀ | 16 |
| Amplitude 2 | AM2 ₃₁ | AM2 ₃₀ | AM2 ₂₉ | AM2 ₂₈ | AM2 ₂₇ | AM2 ₂₆ | AM2 ₂₅ | AM2 ₂₄ | 17 |
| | AM2 ₂₃ | AM2 ₂₂ | AM2 ₂₁ | AM2 ₂₀ | AM2 ₁₉ | AM2 ₁₈ | AM2 ₁₇ | AM2 ₁₆ | 18 |
| | AM2 ₁₅ | AM2 ₁₄ | AM2 ₁₃ | AM2 ₁₂ | AM2 ₁₁ | AM2 ₁₀ | AM2 ₉ | AM2 ₈ | 19 |
| | AM2 ₇ | AM2 ₆ | AM2 ₅ | AM2 ₄ | AM2 ₃ | AM2 ₂ | AM2 ₁ | AM2 ₀ | 20 |
| Phase 2 | PH2 ₃₁ | PH2 ₃₀ | PH2 ₂₉ | PH2 ₂₈ | PH2 ₂₇ | PH2 ₂₆ | PH2 ₂₅ | PH2 ₂₄ | 21 |
| | PH2 ₂₃ | PH2 ₂₂ | PH2 ₂₁ | PH2 ₂₀ | PH2 ₁₉ | PH2 ₁₈ | PH2 ₁₇ | PH2 ₁₆ | 22 |
| | PH2 ₁₅ | PH2 ₁₄ | PH2 ₁₃ | PH2 ₁₂ | PH2 ₁₁ | PH2 ₁₀ | PH2 ₉ | PH2 ₈ | 23 |
| | PH2 ₇ | PH2 ₆ | PH2 ₅ | PH2 ₄ | PH2 ₃ | PH2 ₂ | PH2 ₁ | PH2 ₀ | 24 |
| Calibration applied | CA ₇ | CA ₆ | CA ₅ | CA ₄ | CA ₃ | CA ₂ | CA ₁ | CA ₀ | 25 |
| Undefined | X | X | X | X | X | X | X | X | 26 |
| | X | X | X | X | X | X | X | X | 27 |
| | X | X | X | X | X | X | X | X | 28 |
| | X | X | X | X | X | X | X | X | 29 |

| | | | | | | | | | |
|-----------------|---|---|---|---|---|---|---|---|----|
| | X | X | X | X | X | X | X | X | 30 |
| | X | X | X | X | X | X | X | X | 31 |
| Header Blk Type | 0 | 1 | 0 | 0 | 0 | 0 | 1 | 1 | 32 |

7.21 TIME DRIFT HEADER (optional)

| Bit No. | 0 | 1 | 2 | 3 | 4 | 5 | 6 | 7 | |
|-------------------------|------------------|------------------|------------------|------------------|------------------|------------------|------------------|------------------|----|
| Time of deployment | TD ₆₃ | TD ₆₂ | TD ₆₁ | TD ₆₀ | TD ₅₉ | TD ₅₈ | TD ₅₇ | TD ₅₆ | 1 |
| | TD ₅₅ | TD ₅₄ | TD ₅₃ | TD ₅₂ | TD ₅₁ | TD ₅₀ | TD ₄₉ | TD ₄₈ | 2 |
| | TD ₄₇ | TD ₄₆ | TD ₄₅ | TD ₄₄ | TD ₄₃ | TD ₄₂ | TD ₄₁ | TD ₄₀ | 3 |
| | TD ₃₉ | TD ₃₈ | TD ₃₇ | TD ₃₆ | TD ₃₅ | TD ₃₄ | TD ₃₃ | TD ₃₂ | 4 |
| | TD ₃₁ | TD ₃₀ | TD ₂₉ | TD ₂₈ | TD ₂₇ | TD ₂₆ | TD ₂₅ | TD ₂₄ | 5 |
| | TD ₂₃ | TD ₂₂ | TD ₂₁ | TD ₂₀ | TD ₁₉ | TD ₁₈ | TD ₁₇ | TD ₁₆ | 6 |
| | TD ₁₅ | TD ₁₄ | TD ₁₃ | TD ₁₂ | TD ₁₁ | TD ₁₀ | TD ₉ | TD ₈ | 7 |
| | TD ₇ | TD ₆ | TD ₅ | TD ₄ | TD ₃ | TD ₂ | TD ₁ | TD ₀ | 8 |
| Time of retrieval | TR ₆₃ | TR ₆₂ | TR ₆₁ | TR ₆₀ | TR ₅₉ | TR ₅₈ | TR ₅₇ | TR ₅₆ | 9 |
| | TR ₅₅ | TR ₅₄ | TR ₅₃ | TR ₅₂ | TR ₅₁ | TR ₅₀ | TR ₄₉ | TR ₄₈ | 10 |
| | TR ₄₇ | TR ₄₆ | TR ₄₅ | TR ₄₄ | TR ₄₃ | TR ₄₂ | TR ₄₁ | TR ₄₀ | 11 |
| | TR ₃₉ | TR ₃₈ | TR ₃₇ | TR ₃₆ | TR ₃₅ | TR ₃₄ | TR ₃₃ | TR ₃₂ | 12 |
| | TR ₃₁ | TR ₃₀ | TR ₂₉ | TR ₂₈ | TR ₂₇ | TR ₂₆ | TR ₂₅ | TR ₂₄ | 13 |
| | TR ₂₃ | TR ₂₂ | TR ₂₁ | TR ₂₀ | TR ₁₉ | TR ₁₈ | TR ₁₇ | TR ₁₆ | 14 |
| | TR ₁₅ | TR ₁₄ | TR ₁₃ | TR ₁₂ | TR ₁₁ | TR ₁₀ | TR ₉ | TR ₈ | 15 |
| | TR ₇ | TR ₆ | TR ₅ | TR ₄ | TR ₃ | TR ₂ | TR ₁ | TR ₀ | 16 |
| Timer Offset Deployment | OD ₃₁ | OD ₃₀ | OD ₂₉ | OD ₂₈ | OD ₂₇ | OD ₂₆ | OD ₂₅ | OD ₂₄ | 17 |
| | OD ₂₃ | OD ₂₂ | OD ₂₁ | OD ₂₀ | OD ₁₉ | OD ₁₈ | OD ₁₇ | OD ₁₆ | 18 |
| | OD ₁₅ | OD ₁₄ | OD ₁₃ | OD ₁₂ | OD ₁₁ | OD ₁₀ | OD ₉ | OD ₈ | 19 |
| | OD ₇ | OD ₆ | OD ₅ | OD ₄ | OD ₃ | OD ₂ | OD ₁ | OD ₀ | 20 |
| Time Offset Retrieval | OR ₃₁ | OR ₃₀ | OR ₂₉ | OR ₂₈ | OR ₂₇ | OR ₂₆ | OR ₂₅ | OR ₂₄ | 21 |
| | OR ₂₃ | OR ₂₂ | OR ₂₁ | OR ₂₀ | OR ₁₉ | OR ₁₈ | OR ₁₇ | OR ₁₆ | 22 |
| | OR ₁₅ | OR ₁₄ | OR ₁₃ | OR ₁₂ | OR ₁₁ | OR ₁₀ | OR ₉ | OR ₈ | 23 |
| | OR ₇ | OR ₆ | OR ₅ | OR ₄ | OR ₃ | OR ₂ | OR ₁ | OR ₀ | 24 |
| Timedrift corrected | TDC ₇ | TDC ₆ | TDC ₅ | TDC ₄ | TDC ₃ | TDC ₂ | TDC ₁ | TDC ₀ | 25 |
| Correction method | CM ₇ | CM ₆ | CM ₅ | CM ₄ | CM ₃ | CM ₂ | CM ₁ | CM ₀ | 26 |
| Undefined | X | X | X | X | X | X | X | X | 27 |
| | X | X | X | X | X | X | X | X | 28 |
| | X | X | X | X | X | X | X | X | 29 |
| | X | X | X | X | X | X | X | X | 30 |
| | X | X | X | X | X | X | X | X | 31 |
| Header Blk Type | 0 | 1 | 0 | 0 | 0 | 1 | 0 | 0 | 32 |

7.22 ORIENTATION HEADER (optional)

| Bit No. | 0 | 1 | 2 | 3 | 4 | 5 | 6 | 7 | |
|-----------------|------------------|------------------|------------------|------------------|------------------|------------------|------------------|------------------|---|
| Rotation X axis | RX ₃₁ | RX ₃₀ | RX ₂₉ | RX ₂₈ | RX ₂₇ | RX ₂₆ | RX ₂₅ | RX ₂₄ | 1 |
| | RX ₂₃ | RX ₂₂ | RX ₂₁ | RX ₂₀ | RX ₁₉ | RX ₁₈ | RX ₁₇ | RX ₁₆ | 2 |

| | | | | | | | | | |
|-----------------------|------------------|------------------|------------------|------------------|------------------|------------------|------------------|------------------|----|
| | RX ₁₅ | RX ₁₄ | RX ₁₃ | RX ₁₂ | RX ₁₁ | RX ₁₀ | RX ₉ | RX ₈ | 3 |
| | RX ₇ | RX ₆ | RX ₅ | RX ₄ | RX ₃ | RX ₂ | RX ₁ | RX ₀ | 4 |
| Rotation Y axis | RY ₃₁ | RY ₃₀ | RY ₂₉ | RY ₂₈ | RY ₂₇ | RY ₂₆ | RY ₂₅ | RY ₂₄ | 5 |
| | RY ₂₃ | RY ₂₂ | RY ₂₁ | RY ₂₀ | RY ₁₉ | RY ₁₈ | RY ₁₇ | RY ₁₆ | 6 |
| | RY ₁₅ | RY ₁₄ | RY ₁₃ | RY ₁₂ | RY ₁₁ | RY ₁₀ | RY ₉ | RY ₈ | 7 |
| | RY ₇ | RY ₆ | RY ₅ | RY ₄ | RY ₃ | RY ₂ | RY ₁ | RY ₀ | 8 |
| Rotation Z axis | RZ ₃₁ | RZ ₃₀ | RZ ₂₉ | RZ ₂₈ | RZ ₂₇ | RZ ₂₆ | RZ ₂₅ | RZ ₂₄ | 9 |
| | RZ ₂₃ | RZ ₂₂ | RZ ₂₁ | RZ ₂₀ | RZ ₁₉ | RZ ₁₈ | RZ ₁₇ | RZ ₁₆ | 10 |
| | RZ ₁₅ | RZ ₁₄ | RZ ₁₃ | RZ ₁₂ | RZ ₁₁ | RZ ₁₀ | RZ ₉ | RZ ₈ | 11 |
| | RZ ₇ | RZ ₆ | RZ ₅ | RZ ₄ | RZ ₃ | RZ ₂ | RZ ₁ | RZ ₀ | 12 |
| Reference Orientation | RO ₃₁ | RO ₃₀ | RO ₂₉ | RO ₂₈ | RO ₂₇ | RO ₂₆ | RO ₂₅ | RO ₂₄ | 13 |
| | RO ₂₃ | RO ₂₂ | RO ₂₁ | RO ₂₀ | RO ₁₉ | RO ₁₈ | RO ₁₇ | RO ₁₆ | 14 |
| | RO ₁₅ | RO ₁₄ | RO ₁₃ | RO ₁₂ | RO ₁₁ | RO ₁₀ | RO ₉ | RO ₈ | 15 |
| | RO ₇ | RO ₆ | RO ₅ | RO ₄ | RO ₃ | RO ₂ | RO ₁ | RO ₀ | 16 |
| Time Stamp | TS ₆₃ | TS ₆₂ | TS ₆₁ | TS ₆₀ | TS ₅₉ | TS ₅₈ | TS ₅₇ | TS ₅₆ | 17 |
| | TS ₅₅ | TS ₅₄ | TS ₅₃ | TS ₅₂ | TS ₅₁ | TS ₅₀ | TS ₄₉ | TS ₄₈ | 18 |
| | TS ₄₇ | TS ₄₆ | TS ₄₅ | TS ₄₄ | TS ₄₃ | TS ₄₂ | TS ₄₁ | TS ₄₀ | 19 |
| | TS ₃₉ | TS ₃₈ | TS ₃₇ | TS ₃₆ | TS ₃₅ | TS ₃₄ | TS ₃₃ | TS ₃₂ | 20 |
| | TS ₃₁ | TS ₃₀ | TS ₂₉ | TS ₂₈ | TS ₂₇ | TS ₂₆ | TS ₂₅ | TS ₂₄ | 21 |
| | TS ₂₃ | TS ₂₂ | TS ₂₁ | TS ₂₀ | TS ₁₉ | TS ₁₈ | TS ₁₇ | TS ₁₆ | 22 |
| | TS ₁₅ | TS ₁₄ | TS ₁₃ | TS ₁₂ | TS ₁₁ | TS ₁₀ | TS ₉ | TS ₈ | 23 |
| | TS ₇ | TS ₆ | TS ₅ | TS ₄ | TS ₃ | TS ₂ | TS ₁ | TS ₀ | 24 |
| Orientation Type | OT ₇ | OT ₆ | OT ₅ | OT ₄ | OT ₃ | OT ₂ | OT ₁ | OT ₀ | 25 |
| Ref Orient Valid | ROV ₇ | ROV ₆ | ROV ₅ | ROV ₄ | ROV ₃ | ROV ₂ | ROV ₁ | ROV ₀ | 26 |
| Rotation Applied | RA ₇ | RA ₆ | RA ₅ | RA ₄ | RA ₃ | RA ₂ | RA ₁ | RA ₀ | 27 |
| Rot North Applied | RNA ₇ | RNA ₆ | RNA ₅ | RNA ₄ | RNA ₃ | RNA ₂ | RNA ₁ | RNA ₀ | 28 |
| | X | X | X | X | X | X | X | X | 29 |
| | X | X | X | X | X | X | X | X | 30 |
| | X | X | X | X | X | X | X | X | 31 |
| Header Blk Type | 0 | 1 | 1 | 0 | 0 | 0 | 0 | 0 | 32 |

7.23 MEASUREMENT BLOCK (optional)

NOTE: This block should not be used until final agreement with Energetics is reached regarding the unit of measurement system, and the proper resources are available.

| Bit No. | 0 | 1 | 2 | 3 | 4 | 5 | 6 | 7 | |
|-------------------|------------------|------------------|------------------|------------------|------------------|------------------|------------------|------------------|----|
| Timestamp | TS ₆₃ | TS ₆₂ | TS ₆₁ | TS ₆₀ | TS ₅₉ | TS ₅₈ | TS ₅₇ | TS ₅₆ | 1 |
| | TS ₅₅ | TS ₅₄ | TS ₅₃ | TS ₅₂ | TS ₅₁ | TS ₅₀ | TS ₄₉ | TS ₄₈ | 2 |
| | TS ₄₇ | TS ₄₆ | TS ₄₅ | TS ₄₄ | TS ₄₃ | TS ₄₂ | TS ₄₁ | TS ₄₀ | 3 |
| | TS ₃₉ | TS ₃₈ | TS ₃₇ | TS ₃₆ | TS ₃₅ | TS ₃₄ | TS ₃₃ | TS ₃₂ | 4 |
| | TS ₃₁ | TS ₃₀ | TS ₂₉ | TS ₂₈ | TS ₂₇ | TS ₂₆ | TS ₂₅ | TS ₂₄ | 5 |
| | TS ₂₃ | TS ₂₂ | TS ₂₁ | TS ₂₀ | TS ₁₉ | TS ₁₈ | TS ₁₇ | TS ₁₆ | 6 |
| | TS ₁₅ | TS ₁₄ | TS ₁₃ | TS ₁₂ | TS ₁₁ | TS ₁₀ | TS ₉ | TS ₈ | 7 |
| | TS ₇ | TS ₆ | TS ₅ | TS ₄ | TS ₃ | TS ₂ | TS ₁ | TS ₀ | 8 |
| Measurement Value | VA ₃₁ | VA ₃₀ | VA ₂₉ | VA ₂₈ | VA ₂₇ | VA ₂₆ | VA ₂₅ | VA ₂₄ | 9 |
| | VA ₂₃ | VA ₂₂ | VA ₂₁ | VA ₂₀ | VA ₁₉ | VA ₁₈ | VA ₁₇ | VA ₁₆ | 10 |

| | | | | | | | | | |
|---------------------|-------------------|-------------------|-------------------|-------------------|-------------------|-------------------|------------------|------------------|----|
| | VA ₁₅ | VA ₁₄ | VA ₁₃ | VA ₁₂ | VA ₁₁ | VA ₁₀ | VA ₉ | VA ₈ | 11 |
| | VA ₇ | VA ₆ | VA ₅ | VA ₄ | VA ₃ | VA ₂ | VA ₁ | VA ₀ | 12 |
| Maximum Value | MA ₃₁ | MA ₃₀ | MA ₂₉ | MA ₂₈ | MA ₂₇ | MA ₂₆ | MA ₂₅ | MA ₂₄ | 13 |
| | MA ₂₃ | MA ₂₂ | MA ₂₁ | MA ₂₀ | MA ₁₉ | MA ₁₈ | MA ₁₇ | MA ₁₆ | 14 |
| | MA ₁₅ | MA ₁₄ | MA ₁₃ | MA ₁₂ | MA ₁₁ | MA ₁₀ | MA ₉ | MA ₈ | 15 |
| | MA ₇ | MA ₆ | MA ₅ | MA ₄ | MA ₃ | MA ₂ | MA ₁ | MA ₀ | 16 |
| Minimum Value | MI ₃₁ | MI ₃₀ | MI ₂₉ | MI ₂₈ | MI ₂₇ | MI ₂₆ | MI ₂₅ | MI ₂₄ | 17 |
| | MI ₂₃ | MI ₂₂ | MI ₂₁ | MI ₂₀ | MI ₁₉ | MI ₁₈ | MI ₁₇ | MI ₁₆ | 18 |
| | MI ₁₅ | MI ₁₄ | MI ₁₃ | MI ₁₂ | MI ₁₁ | MI ₁₀ | MI ₉ | MI ₈ | 19 |
| | MI ₇ | MI ₆ | MI ₅ | MI ₄ | MI ₃ | MI ₂ | MI ₁ | MI ₀ | 20 |
| Quantity Type | QT ₁₅ | QT ₁₄ | QT ₁₃ | QT ₁₂ | QT ₁₁ | QT ₁₀ | QT ₉ | QT ₁₈ | 21 |
| | QT ₇ | QT ₆ | QT ₅ | QT ₄ | QT ₃ | QT ₂ | QT ₁ | QT ₁₀ | 22 |
| Unit Of Measure | UOM ₁₅ | UOM ₁₄ | UOM ₁₃ | UOM ₁₂ | UOM ₁₁ | UOM ₁₀ | UOM ₉ | UOM ₈ | 23 |
| | UOM ₇ | UOM ₆ | UOM ₅ | UOM ₄ | UOM ₃ | UOM ₂ | UOM ₁ | UOM ₀ | 24 |
| Geophysical Meaning | GM ₁₅ | GM ₁₄ | GM ₁₃ | GM ₁₂ | GM ₁₁ | GM ₁₀ | GM ₉ | GM ₈ | 25 |
| | GM ₇ | GM ₆ | GM ₅ | GM ₄ | GM ₃ | GM ₂ | GM ₁ | GM ₀ | 26 |
| Undefined | X | X | X | X | X | X | X | X | 27 |
| | X | X | X | X | X | X | X | X | 28 |
| | X | X | X | X | X | X | X | X | 29 |
| | X | X | X | X | X | X | X | X | 30 |
| | X | X | X | X | X | X | X | X | 31 |
| Header Blk Type | 0 | 1 | 1 | 0 | 0 | 0 | 0 | 1 | 32 |

7.24 ELECTROMAGNETIC SRC/RECV DESC BLOCK (optional)

| | | | | | | | | | |
|-----------------------|------------------|------------------|------------------|------------------|------------------|------------------|------------------|------------------|----|
| Bit No. | 0 | 1 | 2 | 3 | 4 | 5 | 6 | 7 | |
| Equipment Dimension X | LX ₂₃ | LX ₂₂ | LX ₂₁ | LX ₂₀ | LX ₁₉ | LX ₁₈ | LX ₁₇ | LX ₁₆ | 1 |
| | LX ₁₅ | LX ₁₄ | LX ₁₃ | LX ₁₂ | LX ₁₁ | LX ₁₀ | LX ₉ | LX ₈ | 2 |
| | LX ₇ | LX ₆ | LX ₅ | LX ₄ | LX ₃ | LX ₂ | LX ₁ | LX ₀ | 3 |
| Equipment Dimension Y | LY ₂₃ | LY ₂₂ | LY ₂₁ | LY ₂₀ | LY ₁₉ | LY ₁₈ | LY ₁₇ | LY ₁₆ | 4 |
| | LY ₁₅ | LY ₁₄ | LY ₁₃ | LY ₁₂ | LY ₁₁ | LY ₁₀ | LY ₉ | LY ₈ | 5 |
| | LY ₇ | LY ₆ | LY ₅ | LY ₄ | LY ₃ | LY ₂ | LY ₁ | LY ₀ | 6 |
| Equipment Dimension Z | LZ ₂₃ | LZ ₂₂ | LZ ₂₁ | LZ ₂₀ | LZ ₁₉ | LZ ₁₈ | LZ ₁₇ | LZ ₁₆ | 7 |
| | LZ ₁₅ | LZ ₁₄ | LZ ₁₃ | LZ ₁₂ | LZ ₁₁ | LZ ₁₀ | LZ ₉ | LZ ₈ | 8 |
| | LZ ₇ | LZ ₆ | LZ ₅ | LZ ₄ | LZ ₃ | LZ ₂ | LZ ₁ | LZ ₀ | 9 |
| Positive terminal | PT ₇ | PT ₆ | PT ₅ | PT ₄ | PT ₃ | PT ₂ | PT ₁ | PT ₀ | 10 |
| Equipment Offset X | OX ₂₃ | OX ₂₂ | OX ₂₁ | OX ₂₀ | OX ₁₉ | OX ₁₈ | OX ₁₇ | OX ₁₆ | 11 |
| | OX ₁₅ | OX ₁₄ | OX ₁₃ | OX ₁₂ | OX ₁₁ | OX ₁₀ | OX ₉ | OX ₈ | 12 |
| | OX ₇ | OX ₆ | OX ₅ | OX ₄ | OX ₃ | OX ₂ | OX ₁ | OX ₀ | 13 |
| Equipment Offset Y | OY ₂₃ | OY ₂₂ | OY ₂₁ | OY ₂₀ | OY ₁₉ | OY ₁₈ | OY ₁₇ | OY ₁₆ | 14 |
| | OY ₁₅ | OY ₁₄ | OY ₁₃ | OY ₁₂ | OY ₁₁ | OY ₁₀ | OY ₉ | OY ₈ | 15 |
| | OY ₇ | OY ₆ | OY ₅ | OY ₄ | OY ₃ | OY ₂ | OY ₁ | OY ₀ | 16 |
| Equipment Offset Z | OZ ₂₃ | OZ ₂₂ | OZ ₂₁ | OZ ₂₀ | OZ ₁₉ | OZ ₁₈ | OZ ₁₇ | OZ ₁₆ | 17 |
| | OZ ₁₅ | OZ ₁₄ | OZ ₁₃ | OZ ₁₂ | OZ ₁₁ | OZ ₁₀ | OZ ₉ | OZ ₈ | 18 |
| | OZ ₇ | OZ ₆ | OZ ₅ | OZ ₄ | OZ ₃ | OZ ₂ | OZ ₁ | OZ ₀ | 19 |
| Undefined | X | X | X | X | X | X | X | X | 20 |
| | X | X | X | X | X | X | X | X | 21 |
| | X | X | X | X | X | X | X | X | 22 |
| | X | X | X | X | X | X | X | X | 23 |

| | | | | | | | | | |
|-----------------|---|---|---|---|---|---|---|---|----|
| | X | X | X | X | X | X | X | X | 24 |
| | X | X | X | X | X | X | X | X | 25 |
| | X | X | X | X | X | X | X | X | 26 |
| | X | X | X | X | X | X | X | X | 27 |
| | X | X | X | X | X | X | X | X | 28 |
| | X | X | X | X | X | X | X | X | 29 |
| | X | X | X | X | X | X | X | X | 30 |
| | X | X | X | X | X | X | X | X | 31 |
| Header Blk Type | 0 | 1 | 0 | 0 | 0 | 1 | 0 | 1 | 32 |

7.25 GENERAL TRAILER DESCRIPTION BLOCK (optional)

| | | | | | | | | | |
|------------------|------------------|------------------|------------------|------------------|------------------|------------------|------------------|------------------|-----|
| Bit No. | 0 | 1 | 2 | 3 | 4 | 5 | 6 | 7 | |
| BCD Value MSD | 8 | 4 | 2 | 1 | 8 | 4 | 2 | 1 | LSD |
| Binary Value MSB | 128 | 64 | 32 | 16 | 8 | 4 | 2 | 1 | LSB |
| Block Type | BT ₇ | BT ₆ | BT ₅ | BT ₄ | BT ₃ | BT ₂ | BT ₁ | BT ₀ | 1 |
| ASCII or binary | AB ₇ | AB ₆ | AB ₅ | AB ₄ | AB ₃ | AB ₂ | AB ₁ | AB ₀ | 2 |
| | 0 | 0 | 0 | 0 | 0 | 0 | 0 | 0 | 3 |
| | 0 | 0 | 0 | 0 | 0 | 0 | 0 | 0 | 4 |
| Block Size | SI ₃₁ | SI ₃₀ | SI ₂₉ | SI ₂₈ | SI ₂₇ | SI ₂₆ | SI ₂₅ | SI ₂₄ | 5 |
| | SI ₂₃ | SI ₂₂ | SI ₂₁ | SI ₂₀ | SI ₁₉ | SI ₁₈ | SI ₁₇ | SI ₁₆ | 6 |
| | SI ₁₅ | SI ₁₄ | SI ₁₃ | SI ₁₂ | SI ₁₁ | SI ₁₀ | SI ₉ | SI ₈ | 7 |
| | SI ₇ | SI ₆ | SI ₅ | SI ₄ | SI ₃ | SI ₂ | SI ₁ | SI ₀ | 8 |
| Description | DE | DE | DE | DE | DE | DE | DE | DE | 9 |
| | DE | DE | DE | DE | DE | DE | DE | DE | 10 |
| | DE | DE | DE | DE | DE | DE | DE | DE | 11 |
| | DE | DE | DE | DE | DE | DE | DE | DE | 12 |
| | DE | DE | DE | DE | DE | DE | DE | DE | 13 |
| | DE | DE | DE | DE | DE | DE | DE | DE | 14 |
| | DE | DE | DE | DE | DE | DE | DE | DE | 15 |
| | DE | DE | DE | DE | DE | DE | DE | DE | 16 |
| | DE | DE | DE | DE | DE | DE | DE | DE | 17 |
| | DE | DE | DE | DE | DE | DE | DE | DE | 18 |
| | DE | DE | DE | DE | DE | DE | DE | DE | 19 |
| | DE | DE | DE | DE | DE | DE | DE | DE | 20 |
| | DE | DE | DE | DE | DE | DE | DE | DE | 21 |
| | DE | DE | DE | DE | DE | DE | DE | DE | 22 |
| | DE | DE | DE | DE | DE | DE | DE | DE | 23 |
| | DE | DE | DE | DE | DE | DE | DE | DE | 24 |
| | 0 | 0 | 0 | 0 | 0 | 0 | 0 | 0 | 25 |
| | 0 | 0 | 0 | 0 | 0 | 0 | 0 | 0 | 26 |
| | 0 | 0 | 0 | 0 | 0 | 0 | 0 | 0 | 27 |
| | 0 | 0 | 0 | 0 | 0 | 0 | 0 | 0 | 28 |
| | 0 | 0 | 0 | 0 | 0 | 0 | 0 | 0 | 29 |
| | 0 | 0 | 0 | 0 | 0 | 0 | 0 | 0 | 30 |
| | 0 | 0 | 0 | 0 | 0 | 0 | 0 | 0 | 31 |
| Header Blk Type | 0 | 1 | 1 | 1 | 0 | 0 | 0 | 0 | 32 |

8.0 HEADER BLOCK PARAMETERS

In cases where extended fields exist (e.g. File Number (General Header #1) and Extended File Number (General Header #2), all nibbles of the original field is set to F_{16} to indicate when the extended field is used. When the normal field is used, the extended field is either set to 0 or the value of the normal field. No other values are allowed.

The different location indexes for sources and receivers (Line, Point, Point index, Depth, Group and Depth) should be recorded as 0 if they are unknown/undetermined unless specified otherwise.

8.1 GENERAL HEADER, BLOCK #1

All values are in packed BCD unless otherwise specified.

| INDEX BYTE | ABBREVIATION | DESCRIPTION | |
|---------------|------------------|---------------------------------------------------------------------------------------------------------------------------------------------------------------------------------------------------------------------------------------------------------------------------------------------------------------------------------------------------|--------------------------------------------------------------------------------------------------------------------------------------------------------------------------------------------------------------------------------------------------------------------------------------------------------------------------------------------------------------------------|
| 1 | F_1, F_2 | File number of four digits (0–9999), set to $FFFF_{16}$ when the file number is greater than 9999. The expanded file number is contained in Bytes 1, 2, and 3 of General Header, Block #2. | |
| 2 | F_3, F_4 | | |
| 3 | Y_1, Y_2 | Format code: 8015 20 bit binary 8022 8 bit quaternary 8024 16 bit quaternary 8036 24 bit 2's complement integer 8038 32 bit 2's complement integer 8042 8 bit hexadecimal 8044 16 bit hexadecimal 8048 32 bit hexadecimal 8058 32 bit IEEE 8080 64 bit IEEE 0200 Illegal, do not use 0000 Illegal, do not use | |
| 4 | Y_3, Y_4 | | |
| 5 | K_1, K_2 | | |
| 6 | K_3, K_4 | | |
| 7 | K_5, K_6 | | |
| 8 | K_7, K_8 | | |
| 9 | K_9, K_{10} | | |
| 10 | K_{11}, K_{12} | | |
| 11 | YR_1, YR_2 | | Last two digits of year (0–99) |
| 12 | GH | | Number of <u>additional</u> Blocks in General Header (unsigned binary). This number will be 2 or greater for Rev 3 (e.g., if only General Header Blocks #1, #2 and #3 are present then $GH = 2$). For each additional block, the value is increased by one.). If more than 14 are required, set to GH to F_{16} , and use bytes 23–24 of the General Header Block #2. |
| 12 | DY_1 | Julian day, 3 digits (1–366). | |
| 13 | DY_2, DY_3 | | |

| | | |
|----|-----------------------------------|---------------------------------------------------------------------------------------------------------------------------------------------------------------------------------------------------------------------------------------------------------------------------------------------------------------------------------------------------------------------------------------------------------------------------------------------------------------------------------------------------------------------------------------------------------------------------------------------------------------------------------------------------------|
| 14 | H ₁ , H ₂ | Hour of day, 2 digits (0–23) (UTC Time). |
| 15 | MI ₁ , MI ₂ | Minute of hour, 2 digits (0–59). |
| 16 | SE ₁ , SE ₂ | Second of minute, 2 digits (0–60). The value 60 is a legal value of this field only during UTC leap seconds. |
| 17 | M ₁ , M ₂ | Manufacturer's code 2 digits Note: See Appendix A for the current assignments |
| 18 | M ₃ , M ₄ | Manufacturer's serial number, 4 digits |
| 19 | M ₅ , M ₆ | |
| 20 | 0 | Not used. Record as zero |
| 21 | 0 | Not used. Record as zero |
| 22 | 0 | Not used. Record as zero |
| 23 | I ₃ – I ₄ | Base scan interval. This is coded as a binary number with the LSB equal to 1/16 msec. This will allow sampling intervals from 1/16 through 8 msec in binary steps. Thus, the allowable base scan intervals are 1/16, 1/8, 1/4, 1/2, 1, 2, 4, and 8 msec. The base scan interval is always the difference between successive timing words. Note: Each channel set is no longer required to have a scan interval that is a multiple of the base scan interval. Instead, this is defined to be the main/dominant scan rate. If a different base scan interval is required, set to FF ₁₆ , and use byte 25–27 in General Header Block #2. |
| 24 | P, | Polarity. These 4 binary bits are measured on the sensors, cables, instrument, and source combination and are set into the system manually. The codes are: 0 ₁₆ Untested 1 ₁₆ Zero 2 ₁₆ 45 degrees 3 ₁₆ 90 degrees 4 ₁₆ 135 degrees 5 ₁₆ 180 degrees 6 ₁₆ 225 degrees 7 ₁₆ 270 degrees 8 ₁₆ 315 degrees C ₁₆ unassigned |
| 24 | X | These 4 bits are not used. |
| 25 | X | These 8 bits are not used. |
| 26 | Z, | Record type 2 ₁₆ Test record 4 ₁₆ Parallel channel test 6 ₁₆ Direct channel test 8 ₁₆ Normal record 1 ₁₆ Other |
| 26 | R ₁ , | Record length from time zero (in increments of 0.5 times 1.024 sec). This value can be set from 00.5 to 99.5 representing times from 0.512 sec. to 101.888 sec. A setting of 00.0 indicates the record length is indeterminate. These three nibbles must be set to FFF ₁₆ when using the Extended Record |
| 27 | R ₂ , R ₃ | |

Length (record length in milliseconds), bytes 17-20, in General Header Block #2. This is the maximum record length for any trace in the record. If Extended Recording Mode is used (General Header #3 byte 29 set to 1), Record Length must be set to 00.0.

| | | |
|----|---------------------------------------|--------------------------------------------------------------------------------------------------------------------------------------------------------------------------------------------------------------------------------------------------------------------------------------------------------------------------------------------------------------------------------------------------------------------------------------------------------------------------------------------------------------------------------------------------------------------------------------------------------------------------------------------------------------------------------------------------------------------------------------|
| 28 | ST/R ₁ , ST/R ₂ | Scan types per record. This 2 digit code is the number of scan types per record (0–99). |
| 29 | CS ₁ , CS ₂ | Number of channel sets per scan type (0–99). (Set to FF ₁₆ when using Extended Channel Sets/Scan Type.) This 2 digit code is the number of channel sets per scan. If multiple scan types are used (such as in a switching sampling interval environment), this number is equal to the number of channel sets contained in the scan type with the largest number of channel sets. If scan types also exist with less than this maximum number of channel sets per scan type, dummy channel set descriptors will have to be recorded in the Scan Type Header. This can be done by setting the number of channels in the dummy channel set descriptor to zero (reference Bytes 21 - 23 of the Scan Type Header description). |
| 30 | SK ₁ , SK ₂ | Number of 32 byte fields added to the end of each scan type header in order to record the sample skew of all channels (0–99). (See Appendix E.2 of the SEG-D Standard). Zero indicates that skew is not recorded. If more skew records are required, set to FF ₁₆ , and use bytes 9 and 10 of General Header Block #2. |
| 31 | EC ₁ , EC ₂ | Extended Header length. The Extended Header is used to record additional equipment parameters. The two digits (0–99) in this field specify the number of 32 byte extensions. If more than 99 extensions, then these bytes are set to FF ₁₆ . Bytes 6, 7 and 8 of General Header Block #2 contain the number of 32 byte extensions. |
| 32 | EX ₁ , EX ₂ | External Header length. The External Header is used to record additional user supplied information in the header. The two digits (0–99) in this field specify the number of 32 byte extensions. If more than 99 extensions, then these bytes are set to FF ₁₆ . Bytes 28, 29 and 30 of General Header Block #2 contain the number of 32 byte extensions. |

8.2 GENERAL HEADER BLOCK #2

| INDEX BYTE | ABBREVIATION | DESCRIPTION |
|---------------|------------------------------------|-----------------------------------------------------------------------------------------------------------------------------------------------------------------------------------------------------------------------------------------------------------------------------------------------------------------------|
| 1,2,3 | EF ₂₃ – EF ₀ | Extended File Number (three bytes, unsigned binary). For file numbers greater than the 9999, bytes 1 and 2 of the General Header Block #1 must be set to FFFF ₁₆ . |
| 4,5 | EN ₁₅ – EN ₀ | Extended Channel Sets/Scan Type (two bytes, unsigned binary). Allows the number of Channel Sets/Scan Type to be greater than the 99 supported in the standard General Header Block #1 (byte 29). When using the Extended Channel Sets/Scan Type, byte 29 of General Header Block #1 must be set to FF ₁₆ . |

| | | |
|----------|--------------------------------------|------------------------------------------------------------------------------------------------------------------------------------------------------------------------------------------------------------------------------------------------------------------------------------------------------------------------------------------------------------------------------------------------------------------------------------------------------------------------------------------------------------------------------------------------------------------------------------------------------------------------------------------------------------------------------------------------------------------------------------------|
| 6,7,8 | ECX ₂₃ – ECX ₀ | Extended Header Blocks (three bytes, unsigned binary). Allows the number of Extended Header Blocks (of 32 bytes each) to be greater than the 99 allowed by the standard General Header Block #1 (byte 31). To use more than 99 Extended Header Blocks, set byte 31 of General Header Block #1 to FF ₁₆ , and use these two bytes. Max size 536,870,880 bytes or 512 MB. |
| 9,10 | ESK ₁₅ – ESK ₀ | Extended Skew Blocks (two bytes, unsigned binary). Number of 32 byte fields added to the end of each scan type header in order to record the sample skew of all channels. (See Appendix E2 of the SEG-D Standard). Zero indicates that skew is not recorded. When using the Extended Skew blocks field, byte 30 of General Header Block #1 must be set to FF ₁₆ . |
| 11 | RMJ ₇ – RMJ ₀ | Major SEG-D Revision Number (one byte, unsigned binary). Set to 03 ₁₆ . |
| 12 | RMN ₇ – RMN ₀ | Minor SEG-D Revision Number (one byte, unsigned binary). Set to 00 ₁₆ . Revisions 0 to 0.N are not valid. This version is Rev 3.0. |
| 13–16 | GT ₃₁ – GT ₀ | Number of Blocks of General Trailer (four bytes, unsigned binary). The number of 32 byte blocks to be used for General Trailers. Max size 137,438,953,408 bytes or 128 GB. If not known at the time (i.e. to allow easy appending of trailer blocks while data is stored on disk), it may be set to FFFFFFFF ₁₆ . The reader will then have to read the trailer block by block to determine the shot size. It is strongly recommended to set this field to its correct value when recording to tape. |
| 17–20 | ERL ₃₁ – ERL ₀ | Extended Record Length (four bytes, unsigned binary) indicates the record length in microseconds. When using extended record length, the record length in the General Header Block #1, the Record Length in bytes 26 and 27 must be set to FFF ₁₆ . A value of 0.0 means record length is indeterminate. Note: This is the maximum record length for any trace in the record. Please refer to the channel set descriptor for actual information of start and end times, number of samples per trace etc. Also note that negative start times are allowed. If Extended Recording Mode is used (General Header #3 byte 29 set to 1), Extended Record Length must be set to 0.0. |
| 21,22 | SN ₁₅ – SN ₀ | Record set number. (two bytes, unsigned binary) This is the sequence number (e.g. the line's unique sequence number), swath number, or any other applicable number that may be used to identify this group of shot records. Set to 0 if not valid. Allows values of 1–65535. |
| 23,24 | EGH ₁₅ – EGH ₀ | Extended Number of <u>additional</u> Blocks in the General Header (two bytes, unsigned binary). This number will be 2 or greater for Rev 3 (e.g. If only General Header Blocks #1, #2 and #3 are present then EGH = 2). For each additional block, the value is increased by one.) When using this field, the upper nibble of byte 12 of General Header Block #1 must be set to F ₁₆ . |
| 25,26,27 | BSI ₂₃ – BSI ₀ | Dominant Sampling Interval (3 bytes, unsigned binary). Only used if General Header Block #1 (byte 23) is set to FF ₁₆ . Dominant sampling interval in microseconds (1/1000000 second). As sample rates allowed in SEG-D Rev 3.0 and above are very flexible, this is no longer related to the <i>base scan interval</i> (term used in Rev 2.x and below) with each channel set being a multiple of it. Instead, it is the main or dominant sampling interval for the record. The sampling interval within each channel set (byte 24-26 of the channel set header) should be used to find the correct sampling interval. This field should not be used to calculate size of records or traces in the record. The field is left |

for backwards compatibility. It can assume a value from 0 to 16,777,215. A value of 0 means the dominant sampling interval is indeterminate.

| | | |
|----------|------------------------------------|----------------------------------------------------------------------------------------------------------------------------------------------------------------------------------------------------------------------------------------------------------------------------------------------------------------------------------------------------------------|
| 28,29,30 | EH ₂₃ – EH ₀ | External Header Blocks (3 bytes, unsigned binary). Allows the number of 32 byte External Header Blocks to be greater than the 99 allowed by General Header Block #1, byte 32. To use more than 99 External Header Blocks, set byte 32 of General Header Block #1 to FF ₁₆ , and use these three bytes. Maximum size is 536,870,880 bytes or 512 MB. |
| 31 | X | These 8 bits are undefined by the format and may have any value. Note: In future versions these may be defined, so use with caution. |
| 32 | HT ₇ – HT ₀ | Header block type (one byte, unsigned binary). The header type indicates what type of information is contained in this header. For General Header Block #2 this byte is set to 02 ₁₆ . |

NOTES:

1. Where the range of allowable numbers is not indicated, the follow ranges apply:
 One byte, unsigned binary, range is 0 – 255
 Two bytes, unsigned binary, range is 0 – 65535
 Three bytes, unsigned binary, range is 0 – 16777215
 Four bytes, unsigned binary, range is 0 – 4294967295

8.3 GENERAL HEADER BLOCK #3 (Timestamp and size header)

| INDEX BYTE | ABBREVIATION | DESCRIPTION |
|---------------|------------------------------------|------------------------------------------------------------------------------------------------------------------------------------------------------------------------------------------------------------------------------------------------------------------------------------------------------------------------------------------------------------------------------------------------------------------------------------------------------------------------------------------------------------------------------------------------------------------------------------------------------------------------------------------------------------------------------------------------------------|
| 1–8 | TZ ₆₃ – TZ ₀ | Time Zero for this record (eight bytes, SEG-D timestamp). The time data and events in this record are offset from (by using e.g. Channel Set Start Time). Matches timestamp in General Header Block #1 bytes 11–16, but is accurate to 1 microsecond. If the recorder does not know the absolute time, this must be recorded as 0, and all timestamps in the record will be relative to this time. If absolute timing of all data traces and events is used in the record (i.e. by utilizing Timestamp Header, Additional Source Info Header etc.), the TZ value may be freely chosen by the recorder. It is however highly recommended to use a time close to the start of the data/events in the record. |
| 9–16 | RS ₆₃ – RS ₀ | Record Size (eight bytes, unsigned binary). The total size of the SEG-D record in number of bytes. May be set to 0 if unknown (e.g., the size of the General Trailer is set to FFFFFFFF ₁₆ in bytes 13–16 in General Header Block #2). It is strongly recommended to set this field to a proper value unless absolutely necessary. If no General Trailer blocks exist, this field is equal to the Data Size (bytes 17–24). The field is very useful for any byte oriented devices like disks or networks. |
| 17–24 | DS ₆₃ – DS ₀ | Data Size (eight bytes, unsigned binary). The total size of the headers and data in this record in number of bytes. This value enables skipping of all traces to the beginning of the trailer. If no General Trailer exists, this is equal to the Record Size (bytes 9–16). The field is very useful for any byte oriented devices like disks and networks. |

| | | |
|-------|-------------------------------------|------------------------------------------------------------------------------------------------------------------------------------------------------------------------------------------------------------------------------------------------------------------------------------------------------------------------------------------------------------------------------|
| 25–28 | HS ₃₁ – HS ₀ | Header Size (four bytes, unsigned binary). The total size of the headers (i.e. General Headers, Channel Set Headers, Skew Headers, External Header, Extended Header, etc.) in this record in number of bytes. This value enables skipping of all headers to the beginning of the first trace. The field is very useful for any byte oriented devices like disks or networks. |
| 29 | ERM ₇ – ERM ₀ | Extended Recording Mode (one byte, unsigned binary). Set to 1 if this record is using the Extended Recording Mode, 0 for normal record. |
| 30 | RTM ₇ – RTM ₀ | Relative Time Mode (one byte, unsigned binary). Set to 1 if this record does not contain absolute timestamps, 0 for normal record. If set to 1, bytes 1 to 8 (TZ) must be set to 0, and all timestamps in the record must be relative to this time (i.e. start of record). |
| 31 | X | These 8 bits are undefined by the format and may have any value. Note: In future versions these may be defined, so use with caution. |
| 32 | HT ₇ – HT ₀ | Header block type (one byte, unsigned binary). The header type indicates what type of information is contained in this header. For General Header Block #3 this byte is set to 03 ₁₆ . |

8.4 GENERAL HEADER BLOCK #4 (Vessel/Crew Identification) (optional)

This block contains the name/description of the vessel or crew.

| INDEX BYTE | ABBREVIATION | DESCRIPTION |
|---------------|-----------------------------------|-------------------------------------------------------------------------------------------------------------------------------------------------------------------------------------------------------|
| 1,2,3 | VCA | Abbreviated vessel or crew name (3 characters, ASCII). May be used on tape labels, etc. Left justified, padded with space (20 ₁₆) characters. May be blank if no abbreviation exists. |
| 4–31 | VC | Vessel or crew name (ASCII text). 28 character vessel or crew name which uniquely identifies the vessel/crew within the enterprise. Left justified, padded with space (20 ₁₆) characters. |
| 32 | HT ₇ – HT ₀ | Header block type (1 byte, unsigned binary). Set to 10 ₁₆ for Vessel/Crew Identification. |

8.5 GENERAL HEADER BLOCK #5 (Survey Area Name) (optional)

This block contains the name/description of the survey area.

| INDEX BYTE | ABBREVIATION | DESCRIPTION |
|---------------|--------------|-------------|
| _____ | _____ | _____ |

| | | |
|------|-----------------------------------|-----------------------------------------------------------------------------------------------------------------------------------------------------------------------------------------------|
| 1–31 | SAN | Survey Area Name (ASCII text). 31 character survey area name which properly identifies the area the record was recorded in. Left justified, padded with space (20 ₁₆) characters. |
| 32 | HT ₇ – HT ₀ | Header block type (1 byte, unsigned binary). Set to 11 ₁₆ for Survey Area Name. |

8.6 GENERAL HEADER BLOCK #6 (Client Identification) (optional)

This block contains the name/description of the client.

| INDEX BYTE | ABBREVIATION | DESCRIPTION |
|---------------|-----------------------------------|-----------------------------------------------------------------------------------------------------------------------------------------------------------------------------------------------------|
| _____ | _____ | _____ |
| 1–31 | CI | Client Identification (ASCII text). 31 character client name/identification which properly identifies the client for this survey. Left justified, padded with space (20 ₁₆) characters. |
| 32 | HT ₇ – HT ₀ | Header block type (1 byte, unsigned binary). Set to 12 ₁₆ for Client Identification. |

8.7 GENERAL HEADER BLOCK #7 (Job identification) (optional)

This block contains the name/description of the job/survey.

| INDEX BYTE | ABBREVIATION | DESCRIPTION |
|---------------|-----------------------------------|------------------------------------------------------------------------------------------------------------------------------------------------------------------------------------------------------------|
| _____ | _____ | _____ |
| 1–5 | JIA | Abbreviated Job Identification (5 characters ASCII). May be used on tape labels etc. Left justified, padded with space (20 ₁₆) characters. May be blank if no abbreviation exists. |
| 6–31 | JI | Job Identification (ASCII text). 26 character job name/number/identification which properly identifies the survey within the enterprise. Left justified, padded with space (20 ₁₆) characters. |
| 32 | HT ₇ – HT ₀ | Header block type (1 byte, unsigned binary). Set to 13 ₁₆ for Job Identification. |

8.8 GENERAL HEADER BLOCK #8 (Line identification) (optional)

This block contains the description of current line. Mainly targeted to Marine operations, however any recorder might use this field for line/swath related information. Make sure the information here matches the sequence number in General Header Block #2, bytes 21–22.

| INDEX BYTE | ABBREVIATION | DESCRIPTION |
|---------------|-----------------------------------|----------------------------------------------------------------------------------------------------------------------------------------------------------------------------------------------------------------------------------------------------------------------------------------------------------------------------------------------------------------|
| 1–7 | LA | Line Abbreviation (ASCII text). 7 character line abbreviation (e.g. line number, though letters are allowed) which uniquely identifies the line within the survey. This is typically the pre-plot line number without information about sequence-number, line type (primary/in-fill/reshoot, etc.) Left justified, padded with space (20_{16}) characters. |
| 8–31 | LI | Line Identification (ASCII text). 24 character line name/identification which uniquely identifies the line within the survey/job. Left justified, padded with space (20_{16}) characters. |
| 32 | HT ₇ – HT ₀ | Header block type (1 byte, unsigned binary). Set to 14_{16} for Line Identification. |

8.9 SOURCE DESCRIPTION BLOCK (optional)

Source description blocks may be inserted into the General Header or relevant Trace Headers (e.g. source auxiliary traces), depending on what is most useful. It is also allowed to replicate Source Description Blocks in the General Header and Trace Headers if that may improve decoding and use of the data.

If multiple source events exist inside the same record, it is required to insert multiple Source Description Blocks describing each of the source events. If the source event does not occur at time zero for the SEG-D record, an Additional Source Info block must be inserted after each source block and the time of the event must be properly stored in bytes 1–8.

If source auxiliary traces are stored in the record, the source description block may be followed by Source Auxiliary Channel Reference blocks describing which traces contain more information regarding the sources.

See Appendix E.7 for examples of how to encode source information.

8.9.1 VIBRATOR

| INDEX BYTE | ABBREVIATION | DESCRIPTION |
|---------------|--------------------------------------|--------------------------------------------------------------------------------------------------------------------------------------------------------------------------------------------------------------------------------------------------------------------------------------------|
| 1–3 | EF ₂₃ – EF ₀ | Expanded File Number (three bytes, unsigned binary). This must be the same value as the file number specified in General Header #1 bytes 1-2 or General Header #2 bytes 1-3. For file numbers greater than 9999, bytes 1 and 2 of the General Header Block #1 must be set to $FFFF_{16}$. |
| 4–6 | SLN ₂₃ – SLN ₀ | Source Line Number, Integer (three bytes, two's complement, signed binary). The Source Description Block contains the source location for one Source/Source Set. Additional Source Description blocks may be used to provide position information for additional Sources/Source sets. |

| | | |
|-------|------------------------|-----------------------------------------------------------------------------------------------------------------------------------------------------------------------------------------------------------------------------------------------------------------------------------------------------------------------------------------------------------------------------------------------------------------------------------------------------------------------------------------------------------------------------------------------------------------------------------------------------------------------------------------------------------------------------------------------|
| 7,8 | $SLN_{-1} - SLN_{-16}$ | Source Line Number, Fraction (two bytes, fixed binary point). The two's complement integer formed by Bytes 4–8 is always equal to 65536 times the full Source Line Number. |
| 9–11 | $SPN_{23} - SPN_0$ | Source Point Number, Integer (three bytes, two's complement, signed binary). |
| 12,13 | $SPN_{-1} - SPN_{-16}$ | Source Point Number, Fraction (two bytes, fixed binary point). The two's complement integer formed by Bytes 9–13 is always equal to 65536 times the full Source Point Number. |
| 14 | $SPI_7 - SPI_0$ | Source Point Index (one byte, unsigned binary). This index allows several locations for the source in the grid, the original value is one and that value is incremented by one every time the source is moved, even when it is moved back to a previous location. A zero value means that the Source Point Index is not recorded. |
| 15 | $PC_7 - PC_0$ | Phase Control (unsigned binary). Identifies the signal used to control the phase of the vibrator output. Assumes following the 1991 Vibrator Polarity Standards: <ul style="list-style-type: none"> 00₁₆ Phase Control not recorded 01₁₆ Baseplate accelerometer 02₁₆ Reaction Mass 03₁₆ Weighted sum (baseplate acceleration times mass plus reaction mass acceleration times its mass) 04₁₆ Direct force measurement <p>It is anticipated that additional codes will be added later. If Phase Control is set to Zero then the Phase Angle (Bytes 17, 18) is undefined.</p> |
| 16 | $V_7 - V_0$ | Type Vibrator (unsigned binary). <ul style="list-style-type: none"> 00₁₆ Type not recorded 01₁₆ P wave vibrator 02₁₆ Shear wave vibrator 03₁₆ Marine vibrator <p>Other types may be added later.</p> |
| 17,18 | $PA_{15} - PA_0$ | Phase Angle (two bytes, two's complement, signed binary). The Phase angle of the intercept of the pilot signal with respect to the phase feedback signal, measured in degrees. Phase Angle is set to zero when Phase Control (Byte 15) is zero (Phase Control not recorded). |
| 19 | $SI_7 - SI_0$ | Source Id (one byte, unsigned binary). The source id is a unique number assigned to each source in the survey. 0 means unknown (same as source set). |
| 20 | $SS_7 - SS_0$ | Source Set Number (one byte, unsigned binary). Used to allow multiple sets of sources. Zero means this source id is not part of a source set (may be a source set by itself). |
| 21 | $RI_7 - RI_0$ | Re-shoot Index (one byte, unsigned binary). The re-shoot index is used to indicate that this shot has been recorded earlier, and this record should replace it. Re-shoot index starts at 0 (indicates recorded for first time). |
| 22 | $GI_7 - GI_0$ | Group Index (one byte, unsigned binary). Group index is used to indicate this record is part of a set of records needed to be processed as a unit. This may be a stack fold number/vibrator sweep number in case of recording records that must |

be stacked prior to processing, or phase index in case of HFVS type of acquisition, where a group of records must be processed to do source separation prior to data processing. 0 means source is not part of a group

| | | |
|-------|------------------|----------------------------------------------------------------------------------------------------------------------------------------------------------------------------------------------------------------------------------------------------------------------------------------------------------------------------------------------------------------------------------------------------------------------------------------------|
| 23 | $DI_7 - DI_0$ | Depth Index (one byte, unsigned binary). The depth index is used to indicate sources fired at different depths on the same location. 0 is not allowed. |
| 24,25 | $OX_{15} - OX_0$ | Offset cross-line (two bytes, two's complement, signed binary). Cross-line offset is number of centimeters (1/100 meter) the source is located from the position indicated by the line/point index number. Used to organize groups of sources firing at the same logical source point, but with different offsets. The offset may be nominal or actual. Set to -32768 (8000_{16}) to indicate unknown offset. |
| 26,27 | $OI_{15} - OI_0$ | Offset in-line (two bytes, two's complement, signed binary). In-line offset is number of centimeters (1/100 meter) the source is located from the position indicated by the line/point index number. Used to organize groups of sources firing at the same logical source point, but with different offsets. The offset may be nominal or actual. Set to -32768 (8000_{16}) to indicate unknown offset. |
| 28,29 | $SZ_{15} - SZ_0$ | Size (two bytes, unsigned binary). The size of the source. For vibrator this is the total peak force generated by the vibrators associated with this source. Unit 100 pound force, i.e. if 4 vibrators of a peak force of 70000lbs is combined in this source, the value of this field is set to 2800. Set to 0 if unknown. |
| 30,31 | $OD_{15} - OD_0$ | Offset depth (two bytes, two's complement, signed binary). Offset depth offset is number of centimeters (1/100 meter) the source is located from the position indicated by the line/point index number. Positive direction upwards. Used to organize groups of sources firing at the same logical source point, but with different offsets. The offset may be nominal or actual. Set to -32768 (8000_{16}) to indicate unknown offset. |
| 32 | $HT_7 - HT_0$ | Header type (one byte, unsigned binary). The header type indicates what type of information is contained in this header. For Vibrator source this byte is set to 15_{16} . |

8.9.2 EXPLOSIVE

| INDEX BYTE | ABBREVIATION | DESCRIPTION |
|---------------|--------------------|--------------------------------------------------------------------------------------------------------------------------------------------------------------------------------------------------------------------------------------------------------------------------------------------|
| 1-3 | $EF_{23} - EF_0$ | Expanded File Number (three bytes, unsigned binary). This must be the same value as the file number specified in General Header #1 bytes 1-2 or General Header #2 bytes 1-3. For file numbers greater than 9999, bytes 1 and 2 of the General Header Block #1 must be set to $FFFF_{16}$. |
| 4-6 | $SLN_{23} - SLN_0$ | Source Line Number, Integer (three bytes, two's complement, signed binary). The Source Description Block contains the source location for one Source/Source Set. Additional Source Description blocks may be used to provide position information for additional Source/Source sets. |

| | | |
|-------|----------------------------------------|-------------------------------------------------------------------------------------------------------------------------------------------------------------------------------------------------------------------------------------------------------------------------------------------------------------------------------------------------------------------------------------------------------------------------------------------------------------------------------------------------------------------------------------------------------------------------------------------------------------------------|
| 7,8 | SLN ₋₁ – SLN ₋₁₆ | Source Line Number, Fraction (two bytes, fixed binary point). The two's complement integer formed by Bytes 4–8 is always equal to 65536 times the full Source Line Number. |
| 9–11 | SPN ₂₃ – SPN ₀ | Source Point Number, Integer (three bytes, two's complement, signed binary). |
| 12,13 | SPN ₋₁ – SPN ₋₁₆ | Source Point Number, Fraction (two bytes, fixed binary point). The two's complement integer formed by Bytes 9–13 is always equal to 65536 times the full Source Point Number. |
| 14 | SPI ₇ – SPI ₀ | Source Point Index (one byte, unsigned binary). This index allows several locations for the source in the grid, the original value is one and that value is incremented by one every time the source is moved, even when it is moved back to a previous location. Zero value means that the Source Point Index is not recorded. |
| 15,16 | DE ₁₅ – DE ₀ | Depth (two bytes, unsigned binary). Nominal shot depth in centimeters (1/100 meter). Set to 0 if unknown. |
| 17 | CL ₇ – CL ₀ | Charge length (one byte, unsigned binary). Length of charge in decimeters (1/10 meter). Set to 0 if unknown. |
| 18 | ST ₇ – ST ₀ | Soil Type (one byte, unsigned binary). This is the nominal type of soil or near surface medium. The following types are defined 00 ₁₆ Water 01 ₁₆ Alluvium 02 ₁₆ Dry sand 03 ₁₆ Weathering 04 ₁₆ Mud 05 ₁₆ Glacial 06 ₁₆ Shale 07 ₁₆ Sand 08 ₁₆ Sandstone 09 ₁₆ Limestone 0A ₁₆ Granite 0B ₁₆ Chalk 0C ₁₆ Gypsum 0D ₁₆ Salt 0E ₁₆ Gabbro FF ₁₆ Other Other types may be added later. |
| 19 | SI ₇ – SI ₀ | Source Id (one byte, unsigned binary). The source id is a unique number assigned to each source in the survey. 0 means unknown (same as source set). |
| 20 | SS ₇ – SS ₀ | Source Set Number (one byte, unsigned binary). Used to allow multiple sets of sources. Zero means this source id is not part of a source set (may be a source set by itself). |
| 21 | RI ₇ – RI ₀ | Re-shoot Index (one byte, unsigned binary). The re-shoot index is used to indicate that this shot has been recorded earlier, and this record should replace it. Re-shoot index starts at 0 (indicates recorded for first time). |

| | | |
|-------|------------------|------------------------------------------------------------------------------------------------------------------------------------------------------------------------------------------------------------------------------------------------------------------------------------------------------------------------------------------------------------------------------------------------------------------------------------------|
| 22 | $GI_7 - GI_0$ | Group Index (one byte, unsigned binary). Group index is used to indicate this record is part of a set of records needed to be processed as a unit. 0 means source not part of a group.. |
| 23 | $DI_7 - DI_0$ | Depth Index (one byte, unsigned binary). The depth index is used to indicate sources fired at different depths on the same location. 0 is not allowed. |
| 24,25 | $OX_{15} - OX_0$ | Offset cross-line (two bytes, two's complement, signed binary). Cross-line offset is number of centimeters (1/100 meter) the source is located from the position indicated by the line/point index number. Used to organize groups of sources firing at the same logical source point, but with different offsets. The offset may be nominal or actual. Set to $-32768 (8000_{16})$ to indicate unknown offset. |
| 26,27 | $OI_{15} - OI_0$ | Offset in-line (two bytes, two's complement, signed binary). In-line offset is number of centimeters (1/100 meter) the source is located from the position indicated by the line/point index number. Used to organize groups of sources firing at the same logical source point, but with different offsets. The offset may be nominal or actual. Set to $-32768 (8000_{16})$ to indicate unknown offset. |
| 28,29 | $SZ_{15} - SZ_0$ | Size (two bytes, two's complement, signed binary). The size of source. For explosive this is the size of charge in grams. Set to 0 if unknown. |
| 30,31 | $OD_{15} - OD_0$ | Offset depth (two bytes, two's complement, signed binary). Offset depth offset is number of centimeters (1/100 meter) the source is located from the position indicated by the line/point index number. Positive direction upwards. Used to organize groups of sources firing at the same logical source point, but with different offsets. The offset may be nominal or actual. Set to $-32768 (8000_{16})$ to indicate unknown offset. |
| 32 | $HT_7 - HT_0$ | Header type (one byte, unsigned binary). The header type indicates what type of information is contained in this header. For Explosive source this byte is set to 16_{16} . |

8.9.3 AIRGUN

| INDEX BYTE | ABBREVIATION | DESCRIPTION |
|---------------|--------------------|--------------------------------------------------------------------------------------------------------------------------------------------------------------------------------------------------------------------------------------------------------------------------------------------|
| 1-3 | $EF_{23} - EF_0$ | Expanded File Number (three bytes, unsigned binary). This must be the same value as the file number specified in General Header #1 bytes 1-2 or General Header #2 bytes 1-3. For file numbers greater than 9999, bytes 1 and 2 of the General Header Block #1 must be set to $FFFF_{16}$. |
| 4-6 | $SLN_{23} - SLN_0$ | Source Line Number, Integer (three bytes, two's complement, signed binary). The Source Description Block contains the source location for one Source/Source Set. Additional Source Description blocks may be used to provide position information for additional Source/Source sets. |

| | | |
|-------|----------------------------------------|-------------------------------------------------------------------------------------------------------------------------------------------------------------------------------------------------------------------------------------------------------------------------------------------------------------------------------------------------------------------------------------------------------------------------|
| 7,8 | SLN ₋₁ – SLN ₋₁₆ | Source Line Number, Fraction (two bytes, fixed binary point). The two's complement integer formed by Bytes 4–8 is always equal to 65536 times the full Source Line Number. |
| 9–11 | SPN ₂₃ – SPN ₀ | Source Point Number, Integer (three bytes, two's complement, signed binary). |
| 12,13 | SPN ₋₁ – SPN ₋₁₆ | Source Point Number, Fraction (two bytes, fixed binary point). The two's complement integer formed by Bytes 9–13 is always equal to 65536 times the full Source Point Number. |
| 14 | SPI ₇ – SPI ₀ | Source Point Index (one byte, unsigned binary). This index allows several locations for the source in the grid, the original value is one and that value is incremented by one every time the source is moved, even when it is moved back to a previous location. Zero value means that the Source Point Index is not recorded. |
| 15,16 | DE ₁₅ – DE ₀ | Depth (two bytes, unsigned binary). This is the nominal depth from the water surface in centimeters (1/100 meter) for this source. Allows values of 0–655.35 meters. Set to 0 if unknown. |
| 17,18 | AP ₁₅ – AP ₀ | Air Pressure (two bytes, unsigned binary). The nominal operating air pressure Unit is PSI. Set to 0 if unknown. |
| 19 | SI ₇ – SI ₀ | Source Id (one byte, unsigned binary). The source id is a unique number assigned to each source in the survey. 0 means unknown (same as source set). |
| 20 | SS ₇ – SS ₀ | Source Set Number (one byte, unsigned binary). Used to allow multiple sets of sources. Zero means this source id is not part of a source set (may be a source set by itself). |
| 21 | RI ₇ – RI ₀ | Re-shoot Index (one byte, unsigned binary). The re-shoot index is used to indicate that this shot has been recorded earlier, and this record should replace it. Re-shoot index starts at 0 (indicates recorded for first time). |
| 22 | GI ₇ – GI ₀ | Group Index (one byte, unsigned binary). Group index is used to indicate this record is part of a set of records needed to be processed as a unit. 0 means source not part of a group. |
| 23 | DI ₇ – DI ₀ | Depth Index (one byte, unsigned binary). The depth index is used to indicate sources fired at different depths on the same location. 0 is not allowed. |
| 24,25 | OX ₁₅ – OX ₀ | Offset cross-line (two bytes, two's complement, signed binary). Cross-line offset is number of centimeters (1/100 meter) the source is located from the position indicated by the line/point index number. Used to organize groups of sources firing at the same logical source point, but with different offsets. The offset may be nominal or actual. Set to -32768 (8000 ₁₆) to indicate unknown offset. |
| 26,27 | OI ₁₅ – OI ₀ | Offset in-line (two bytes, two's complement, signed binary). In-line offset is number of centimeters (1/100 meter) the source is located from the position indicated by the line/point index number. Used to organize groups of sources firing at the same logical source point, but with different offsets. The offset may be nominal or actual. Set to -32768 (8000 ₁₆) to indicate unknown offset. |

| | | |
|-------|------------------|---------------------------------------------------------------------------------------------------------------------------------------------------------------------------------------------------------------------------------------------------------------------------------------------------------------------------------------------------------------------------------------------------------------------------------------------------|
| 28,29 | $SZ_{15} - SZ_0$ | Size (two bytes, two's complement, signed binary). The size of source. For Airgun this is the combined volume of the guns associated with this source ID. Unit cubic inches. Set to 0 if unknown. |
| 30,31 | $OD_{15} - OD_0$ | Offset depth (two bytes, two's complement, signed binary). Offset depth offset is number of centimeters (1/100 meter) the source is located from the position indicated by the line/point index number. Positive direction upwards. Used to organize groups of sources firing at the same logical source point, but with different offsets. The offset may be nominal or actual. Set to -32768 (8000 ₁₆) to indicate unknown offset. |
| 32 | $HT_7 - HT_0$ | Header type (one byte, unsigned binary). The header type indicates what type of information is contained in this header. For Airgun source this byte is set to 17 ₁₆ . |

8.9.4 WATERGUN

| INDEX BYTE | ABBREVIATION | DESCRIPTION |
|------------|------------------------|---------------------------------------------------------------------------------------------------------------------------------------------------------------------------------------------------------------------------------------------------------------------------------------------------------------------------------|
| 1-3 | $EF_{23} - EF_0$ | Expanded File Number (three bytes, unsigned binary). This must be the same value as the file number specified in General Header #1 bytes 1-2 or General Header #2 bytes 1-3. For file numbers greater than 9999, bytes 1 and 2 of the General Header Block #1 must be set to FFFF ₁₆ . |
| 4-6 | $SLN_{23} - SLN_0$ | Source Line Number, Integer (three bytes, two's complement, signed binary). The Source Description Block contains the source location for one Source/Source Set. Additional Source Description blocks may be used to provide position information for additional Source/Source sets. |
| 7,8 | $SLN_{-1} - SLN_{-16}$ | Source Line Number, Fraction (two bytes, fixed binary point). The two's complement integer formed by Bytes 4-8 is always equal to 65536 times the full Source Line Number. |
| 9-11 | $SPN_{23} - SPN_0$ | Source Point Number, Integer (three bytes, two's complement, signed binary). |
| 12,13 | $SPN_{-1} - SPN_{-16}$ | Source Point Number, Fraction (two bytes, fixed binary point). The two's complement integer formed by Bytes 9-13 is always equal to 65536 times the full Source Point Number. |
| 14 | $SPI_7 - SPI_0$ | Source Point Index (one byte, unsigned binary). This index allows several locations for the source in the grid, the original value is one and that value is incremented by one every time the source is moved, even when it is moved back to a previous location. Zero value means that the Source Point Index is not recorded. |
| 15,16 | $DE_{15} - DE_0$ | Depth (two bytes, unsigned binary). This is the nominal depth from the water surface in centimeters (1/100 meter) for this source. Set to 0 if unknown. |
| 17,18 | $AP_{15} - AP_0$ | Air Pressure (two bytes, unsigned binary). The nominal operating air pressure Unit is PSI. Set to 0 if unknown. |

| | | |
|-------|------------------------------------|---------------------------------------------------------------------------------------------------------------------------------------------------------------------------------------------------------------------------------------------------------------------------------------------------------------------------------------------------------------------------------------------------------------------------------------------------|
| 19 | SI ₇ – SI ₀ | Source Id (one byte, unsigned binary). The source id is a unique number assigned to each source in the survey. 0 means unknown (same as source set). |
| 20 | SS ₇ – SS ₀ | Source Set Number (one byte, unsigned binary). Used to allow multiple sets of sources. Zero means this source id is not part of a source set (may be a source set by itself). |
| 21 | RI ₇ – RI ₀ | Re-shoot Index (one byte, unsigned binary). The re-shoot index is used to indicate that this shot has been recorded earlier, and this record should replace it. Re-shoot index starts at 0 (indicates recorded for first time). |
| 22 | GI ₇ – GI ₀ | Group Index (one byte, unsigned binary). Group index is used to indicate this record is part of a set of records needed to be processed as a unit. 0 means source not part of a group. |
| 23 | DI ₇ – DI ₀ | Depth Index (one byte, unsigned binary). The depth index is used to indicate sources fired at different depths on the same location. 0 is not allowed. |
| 24,25 | OX ₁₅ – OX ₀ | Offset cross-line (two bytes, two's complement, signed binary). Cross-line offset is number of centimeters (1/100 meter) the source is located from the position indicated by the line/point index number. Used to organize groups of sources firing at the same logical source point, but with different offsets. The offset may be nominal or actual. Set to -32768 (8000 ₁₆) to indicate unknown offset. |
| 26,27 | OI ₁₅ – OI ₀ | Offset in-line (two bytes, two's complement, signed binary). In-line offset is number of centimeters (1/100 meter) the source is located from the position indicated by the line/point index number. Used to organize groups of sources firing at the same logical source point, but with different offsets. The offset may be nominal or actual. Set to -32768 (8000 ₁₆) to indicate unknown offset. |
| 28,29 | SZ ₁₅ – SZ ₀ | Size (two bytes, two's complement, signed binary). The size of source. For Watergun this is the total volume of guns associated with this source ID. Unit cubic inches. Set to 0 if unknown. |
| 30,31 | OD ₁₅ – OD ₀ | Offset depth (two bytes, two's complement, signed binary). Offset depth offset is number of centimeters (1/100 meter) the source is located from the position indicated by the line/point index number. Positive direction upwards. Used to organize groups of sources firing at the same logical source point, but with different offsets. The offset may be nominal or actual. Set to -32768 (8000 ₁₆) to indicate unknown offset. |
| 32 | HT ₇ – HT ₀ | Header type (one byte, unsigned binary). The header type indicates what type of information is contained in this header. For Watergun source this byte is set to 18 ₁₆ . |

8.9.5 ELECTROMAGNETIC

| INDEX BYTE | ABBREVIATION | DESCRIPTION |
|---------------|--------------|-------------|
|---------------|--------------|-------------|

| | | | | | | | | | | | | | | | | |
|-----------|------------------------|-------------------------------------------------------------------------------------------------------------------------------------------------------------------------------------------------------------------------------------------------------------------------------------------------------------------------------------------------------------------------------------------------------------------------------------------------------------------------------------------------------------------------------------------------|-----------|---------|-----------|--------|-----------|-----------|-----------|----------|-----------|-----------|-----------|-------------|-----------|-------|
| 1-3 | $EF_{23} - EF_0$ | Expanded File Number (three bytes, unsigned binary). This must be the same value as the file number specified in General Header #1 bytes 1-2 or General Header #2 bytes 1-3. For file numbers greater than 9999, bytes 1 and 2 of the General Header Block #1 must be set to $FFFF_{16}$. | | | | | | | | | | | | | | |
| 4-6 | $SLN_{23} - SLN_0$ | Source Line Number, Integer (three bytes, two's complement, signed binary). The Source Description Block contains the source location for one Source/Source Set. Additional Source Description blocks may be used to provide position information for additional Source/Source sets. | | | | | | | | | | | | | | |
| 7,8 | $SLN_{-1} - SLN_{-16}$ | Source Line Number, Fraction (two bytes, fixed binary point). The two's complement integer formed by Bytes 4-8 is always equal to 65536 times the full Source Line Number. | | | | | | | | | | | | | | |
| 9-11 | $SPN_{23} - SPN_0$ | Source Point Number, Integer (three bytes, two's complement, signed binary). | | | | | | | | | | | | | | |
| 12,13 | $SPN_{-1} - SPN_{-16}$ | Source Point Number, Fraction (two bytes, fixed binary point). The two's complement integer formed by Bytes 9-13 is always equal to 65536 times the full Source Point Number. | | | | | | | | | | | | | | |
| 14 | $SPI_7 - SPI_0$ | Source Point Index (one byte, unsigned binary). This index allows several locations for the source in the grid, the original value is one and that value is incremented by one every time the source is moved, even when it is moved back to a previous location. Zero value means that the Source Point Index is not recorded. | | | | | | | | | | | | | | |
| 15 | $ST_7 - ST_0$ | EM Source Type (one byte, unsigned binary). One of the following source types: <table border="0" style="margin-left: 40px;"> <tr><td>00_{16}</td><td>Unknown</td></tr> <tr><td>01_{16}</td><td>Dipole</td></tr> <tr><td>02_{16}</td><td>Loop Coil</td></tr> <tr><td>03_{16}</td><td>Airborne</td></tr> <tr><td>04_{16}</td><td>Open Loop</td></tr> <tr><td>05_{16}</td><td>Closed loop</td></tr> <tr><td>$0F_{16}$</td><td>Other</td></tr> </table> | 00_{16} | Unknown | 01_{16} | Dipole | 02_{16} | Loop Coil | 03_{16} | Airborne | 04_{16} | Open Loop | 05_{16} | Closed loop | $0F_{16}$ | Other |
| 00_{16} | Unknown | | | | | | | | | | | | | | | |
| 01_{16} | Dipole | | | | | | | | | | | | | | | |
| 02_{16} | Loop Coil | | | | | | | | | | | | | | | |
| 03_{16} | Airborne | | | | | | | | | | | | | | | |
| 04_{16} | Open Loop | | | | | | | | | | | | | | | |
| 05_{16} | Closed loop | | | | | | | | | | | | | | | |
| $0F_{16}$ | Other | | | | | | | | | | | | | | | |
| 16-18 | $MO_{23} - MO_0$ | Source Moment (three bytes, unsigned binary). The source moment in AmpereMeter (for Dipole source) or AmperMeter ² (for Coil source). Set to 0 if unknown. | | | | | | | | | | | | | | |
| 19 | $SI_7 - SI_0$ | Source Id (one byte, unsigned binary). The source id is a unique number assigned to each source in the survey. 0 means unknown (same as source set). | | | | | | | | | | | | | | |
| 20 | $SS_7 - SS_0$ | Source Set Number (one byte, unsigned binary). Used to allow multiple sets of sources. Zero means this source id is not part of a source set (may be a source set by itself). | | | | | | | | | | | | | | |
| 21 | $RI_7 - RI_0$ | Re-shoot Index (one byte, unsigned binary). The re-shoot index is used to indicate that this shot has been recorded earlier, and this record should replace it. Re-shoot index starts at 0 (indicates recorded for first time). | | | | | | | | | | | | | | |

| | | |
|-------|------------------|------------------------------------------------------------------------------------------------------------------------------------------------------------------------------------------------------------------------------------------------------------------------------------------------------------------------------------------------------------------------------------------------------------------------------------------|
| 22 | $GI_7 - GI_0$ | Group Index (one byte, unsigned binary). Group index is used to indicate this record is part of a set of records needed to be processed as a unit. 0 means source not part of a group. |
| 23 | $DI_7 - DI_0$ | Depth Index (one byte, unsigned binary). The depth index is used to indicate sources fired at different depths on the same location. 0 is not allowed. |
| 24,25 | $OX_{15} - OX_0$ | Offset cross-line (two bytes, two's complement, signed binary). Cross-line offset is number of centimeters (1/100 meter) the source is located from the position indicated by the line/point index number. Used to organize groups of sources firing at the same logical source point, but with different offsets. The offset may be nominal or actual. Set to $-32768 (8000_{16})$ to indicate unknown offset. |
| 26,27 | $OI_{15} - OI_0$ | Offset in-line (two bytes, two's complement, signed binary). In-line offset is number of centimeters (1/100 meter) the source is located from the position indicated by the line/point index number. Used to organize groups of sources firing at the same logical source point, but with different offsets. The offset may be nominal or actual. Set to $-32768 (8000_{16})$ to indicate unknown offset. |
| 28,29 | $CV_{15} - CV_0$ | Source Current or Voltage (two bytes, unsigned binary). The source current (in Ampere) or voltage (in Volts), depending on the source type. Set to 0 if unknown. |
| 30,31 | $OD_{15} - OD_0$ | Offset depth (two bytes, two's complement, signed binary). Offset depth offset is number of centimeters (1/100 meter) the source is located from the position indicated by the line/point index number. Positive direction upwards. Used to organize groups of sources firing at the same logical source point, but with different offsets. The offset may be nominal or actual. Set to $-32768 (8000_{16})$ to indicate unknown offset. |
| 32 | $HT_7 - HT_0$ | Header type (one byte, unsigned binary). The header type indicates what type of information is contained in this header. For Electromagnetic source this byte is set to 19_{16} . |

8.9.6 OTHER SOURCE

| INDEX BYTE | ABBREVIATION | DESCRIPTION |
|---------------|--------------------|--------------------------------------------------------------------------------------------------------------------------------------------------------------------------------------------------------------------------------------------------------------------------------------------|
| 1-3 | $EF_{23} - EF_0$ | Expanded File Number (three bytes, unsigned binary). This must be the same value as the file number specified in General Header #1 bytes 1-2 or General Header #2 bytes 1-3. For file numbers greater than 9999, bytes 1 and 2 of the General Header Block #1 must be set to $FFFF_{16}$. |
| 4,5,6 | $SLN_{23} - SLN_0$ | Source Line Number, Integer (three bytes, two's complement, signed binary). The Source Description Block contains the source location for one Source/Source Set. Additional Source Description Blocks may be used to provide position information for additional Source/Source sets. |

| | | |
|-------------|------------------------|------------------------------------------------------------------------------------------------------------------------------------------------------------------------------------------------------------------------------------------------------------------------------------------------------------------------------------------------------------------------------------------------------------------------|
| 7,8 | $SLN_{-1} - SLN_{-16}$ | Source Line Number, Fraction (two bytes, fixed binary point). The two's complement integer formed by Bytes 4–8 is always equal to 65536 times the full Source Line Number. |
| 9–11 | $SPN_{23} - SPN_0$ | Source Point Number, Integer (three bytes, two's complement, signed binary). |
| 12,13 | $SPN_{-1} - SPN_{-16}$ | Source Point Number, Fraction (two bytes, fixed binary point). The two's complement integer formed by Bytes 9–13 is always equal to 65536 times the full Source Point Number. |
| 14 | $SPI_7 - SPI_0$ | Source Point Index (one byte, unsigned binary). This index allows several locations for the source in the grid, the original value is one and that value is incremented by one every time the source is moved, even when it is moved back to a previous location. Zero value means that the Source Point Index is not recorded. |
| 15,16,17,18 | X | Unused, may have any value. |
| 19 | $SI_7 - SI_0$ | Source Id (one byte, unsigned binary). The source id is a unique number assigned to each source in the survey. 0 means unknown (same as source set). |
| 20 | $SS_7 - SS_0$ | Source Set Number (one byte, unsigned binary). Used to allow multiple sets of sources. Zero means this source id is not part of a source set (may be a source set by itself). |
| 21 | $RI_7 - RI_0$ | Re-shoot Index (one byte, unsigned binary). The re-shoot index is used to indicate that this shot has been recorded earlier, and this record should replace it. Re-shoot index starts at 0 (indicates recorded for first time). |
| 22 | $GI_7 - GI_0$ | Group Index (one byte, unsigned binary). Group index is used to indicate this record is part of a set of records needed to be processed as a unit. 0 means source is not part of a group. |
| 23 | $DI_7 - DI_0$ | Depth Index (one byte, unsigned binary). The depth index is used to indicate sources fired at different depths on the same location. 0 is not allowed. |
| 24,25 | $OX_{15} - OX_0$ | Offset cross-line (two bytes, two's complement, signed binary). Cross-line offset is number of centimeters (1/100 meter) the source is located from the position indicated by the line/point index number. Used to organize groups of sources firing at the same logical source point, but with different offset to it. The offset may be nominal or actual. Set to -32768 (8000_{16}) to indicate unknown offset. |
| 26,27 | $OI_{15} - OI_0$ | Offset in-line (two bytes, two's complement, signed binary). In-line offset is number of centimeters (1/100 meter) the source is located from the position indicated by the line/point index number. Used to organize groups of sources firing at the same logical source point, but with different offset to it. The offset may be nominal or actual. Set to -32768 (8000_{16}) to indicate unknown offset. |
| 28,29 | X | Unused space, may have any value. |
| 30,31 | $OD_{15} - OD_0$ | Offset depth (two bytes, two's complement, signed binary). Offset depth offset is number of centimeters (1/100 meter) the source is located from the position indicated by the line/point index number. Positive direction upwards. Used to |

organize groups of sources firing at the same logical source point, but with different offsets. The offset may be nominal or actual. Set to -32768 (8000₁₆) to indicate unknown offset.

32 HT₇ – HT₀ Header type (one byte, unsigned binary). The header type indicates what type of information is contained in this header. For Other Source this byte is set to 1F₁₆.

8.10 ADDITIONAL SOURCE INFO (optional)

Follows the Source Description Block

| INDEX BYTE | ABBREVIATION | DESCRIPTION |
|------------|-------------------------------------|-------------------------------------------------------------------------------------------------------------------------------------------------------------------------------------------------------------------------------------------------------------------------------------------------------------------------------------------------------------------------------------------------------------------------|
| 1–8 | T ₆₃ – T ₀ | Time (eight bytes, SEG-D timestamp). A time of 0 is allowed, and will indicate source fired at start of record (time as indicated in General Header Block #3, bytes 1 to 8). |
| 9 | SST ₇ – SST ₀ | Source Status (1 byte, unsigned binary) 00 ₁₆ Untested/unknown status 01 ₁₆ Source fired OK 12 ₁₆ Timing error 13 ₁₆ Mechanical failure 14 ₁₆ Software error 15 ₁₆ Hydraulics failure 16 ₁₆ Air leakage 17 ₁₆ Power failure 18 ₁₆ Communication failure FF ₁₆ Unknown error |
| 10 | SI ₇ – SI ₀ | Source Id (one byte, unsigned binary). The source id is a unique number assigned to each source in the survey. 0 means unknown (same as source set). Used to determine which source block this block belongs to. |
| 11 | MV ₇ – MV ₀ | Source Moving (one byte, unsigned binary). Source moving or stationary flag. Set to 1 if source is moving during the record, 0 if stationary. |
| 12–31 | ED | Error Description (20 bytes, ASCII text). Error description in free text as defined by the recorder. The text should be a human readable string. "OK" should be used to indicate the source fired OK, however if another string would better represent the status, the recorder is free to do so. Field is left justified, and unused characters should be filled with spaces (20 ₁₆). |
| 32 | HT ₇ – HT ₀ | Header type (one byte, unsigned binary). The header type indicates what type of information is contained in this header. For Additional Source Info this byte is set to 20 ₁₆ . |

8.11 SOURCE AUXILIARY CHANNEL REFERENCE (optional)

Follows the Source Description Block

This block is inserted into the General Header (or Trace Header) after the Source Description Block to indicate which auxiliary channels contain information data regarding the source. Multiple Source Auxiliary Channel Reference blocks may be used for each source if necessary. May be inserted into (auxiliary source) trace headers to indicate which (other) traces are related to the source.

A value of 0 for Source Id, Scan Type Number, Channel Set Number and Trace Number means no channel referenced.

| INDEX BYTE | ABBREVIATION | DESCRIPTION |
|---------------|--------------------------------------|--------------------------------------------------------------------------------------------------------------------------------------------------------------------------------------------------------|
| 1 | SI ₇ – SI ₀ | Source Id (one byte, unsigned binary). The source id is a unique number assigned to each source in the survey. |
| 2 | ST ₁₁ , ST ₁₂ | Channel 1, Scan Type Number (one byte, two digit, BCD). Currently only values 1–99 allowed. |
| 3,4 | CS ₁₅ – CS ₁₀ | Channel 1, Channel Set Number (two bytes, unsigned binary). |
| 5–7 | TN ₂₃ – TN ₁₀ | Channel 1, Trace Number (3 bytes, unsigned binary). |
| 8 | ST ₂₁ , ST ₂₂ | Channel 2, Scan Type Number (one byte, two digit, BCD). Currently only values 1–99 allowed. |
| 9,10 | CS ₂₅ – CS ₂₀ | Channel 2, Channel Set Number (two bytes, unsigned binary). |
| 11–13 | TN ₂₃ – TN ₂₀ | Channel 2, Trace Number (three bytes, unsigned binary). |
| 14 | ST ₃₁ , ST ₃₂ | Channel 3, Scan Type Number (one byte, two digit, BCD). Currently only values 1–99 allowed. |
| 15,16 | CS ₃₅ – CS ₃₀ | Channel 3, Channel Set Number (two bytes, unsigned binary). |
| 17–19 | TN ₃₂₃ – TN ₃₀ | Channel 3, Trace Number (three byte, unsigned binary). |
| 20 | ST ₄₁ , ST ₄₂ | Channel 4, Scan Type Number (one byte, two digit, BCD). Currently only values 1–99 allowed. |
| 21, 22 | CS ₄₅ – CS ₄₀ | Channel 4, Channel Set Number (two bytes, unsigned binary). |
| 23–25 | TN ₄₂₃ – TN ₄₀ | Channel 4, Trace Number. (three byte, unsigned binary). |
| 26 | ST ₅₁ , ST ₅₂ | Channel 5, Scan Type Number (one byte, two digit, BCD). Currently only values 1–99 allowed. |
| 27, 28 | CS ₅₅ – CS ₅₀ | Channel 5, Channel Set Number (two bytes, unsigned binary). |
| 29–31 | TN ₅₂₃ – TN ₅₀ | Channel 5, Trace Number (three bytes, unsigned binary). |
| 32 | HT ₇ – HT ₀ | Header type (one byte, unsigned binary). The header type indicates what type of information is contained in this header. For Source Auxiliary Channel Reference this byte is set to 21 ₁₆ . |

8.12 COORDINATE REFERENCE SYSTEM IDENTIFICATION (conditional)

This header block is mandatory if a position block is included in the record.

| INDEX BYTE | ABBREVIATION | DESCRIPTION |
|---------------|-----------------------------------|-----------------------------------------------------------------------------------------------------------------------------------------------------------------------------------------------------------------------------------------------------------------------------------------------------------------------------------------------------------------------------------------------------------------------------------------------------------------------------------------------------------------------------------------------------------------------------------------------------------------------------------------------------------------------------------------------------|
| 1–31 | CRID | CRS ID (31 bytes, ASCII text). The coordinate reference system (CRS) identification in a textual format as defined in Appendix D. The string contains all stanzas (including Location Data and Location Data Transformation stanzas) used in the record, concatenated into a continuous string. It is recommended that each stanza is separated by a newline terminator ('\n', 0A ₁₆) or Carriage Return/LineFeed ('\r\n', 0D0A ₁₆). The string is split into 31 byte blocks, and stored in multiple, consecutive CRS identification blocks as part of the General Header. Text is left justified, the block is padded with space (20 ₁₆) characters if needed. |
| 32 | HT ₇ – HT ₀ | Header type (one byte, unsigned binary). The header type indicates what type of information is contained in this header. For Coordinate Reference System Identification this byte is set to 55 ₁₆ . |

8.13 POSITION BLOCKS (optional)

| INDEX BYTE | ABBREVIATION | DESCRIPTION |
|---------------|--------------------------------------|--------------------------------------------------------------------------------------------------------------------------------------------------------------------------------------------------------------------------------------------------------------------------------------------------------------------------------------------------|
| 1–8 | TP ₆₃ – TP ₀ | Time of position (eight bytes, SEG-D timestamp). Time to which this position applies, i.e., sample time. |
| 9–16 | TC ₆₃ – TC ₀ | Time of measurement/calculation (eight bytes, SEG-D timestamp). Time the position was measured or calculated. |
| 17–20 | VE ₃₁ – VE ₀ | Vertical error quality estimate: 95% precision estimate in same units as vertical coordinate (four bytes, IEEE float). Set to 0 if coordinate reference type only uses the horizontal plane. Set to infinity (exponent all bits set, mantissa all zeroes) if not available. |
| 21–24 | HEA ₃₁ – HEA ₀ | Horizontal error quality estimate: 95% error ellipse semi-major axis in same units as horizontal coordinate (four bytes, IEEE float). Set to 0 if coordinate reference type only uses the vertical plane. Set to infinity (exponent all bits set, mantissa all zeroes) if not available. HEA, HEB and HEO must all be valid, or all be infinity. |
| 25–28 | HEB ₃₁ – HEB ₀ | Horizontal error quality estimate: 95% error ellipse semi-minor axis in same units as horizontal coordinate (four bytes, IEEE float). Set to 0 if coordinate reference type only uses the vertical plane. Set to infinity (exponent all bits set, |

mantissa all zeroes) if not available. HEA, HEB and HEO must all be valid, or all be infinity.

| | | | | | | | | | | | | |
|------------------|--------------------------------------|-------------------------------------------------------------------------------------------------------------------------------------------------------------------------------------------------------------------------------------------------------------------------------------------------------------------------------------------------------------------------------------------------------------------------------|------------------|-----------------|------------------|----------|------------------|-----------|------------------|-------|------------------|---------|
| 29–30 | HEO ₁₅ – HEO ₀ | Horizontal error quality estimate: Bearing of error ellipse semi-major axis (two bytes, unsigned binary). Orientation to map grid north in steps of 1/100 of a degree. Set to 0 if coordinate reference type only uses the vertical plane. Set FFFF ₁₆ if not available. HEA, HEB and HEO must all be valid, or all be infinity. | | | | | | | | | | |
| 31 | PT ₇ – PT ₀ | Position type (one byte, unsigned binary). The type of position, the following types are supported: <table border="0" style="margin-left: 40px;"> <tr><td>01₁₆</td><td>Planned/preplot</td></tr> <tr><td>02₁₆</td><td>Measured</td></tr> <tr><td>03₁₆</td><td>Processed</td></tr> <tr><td>04₁₆</td><td>Final</td></tr> <tr><td>0F₁₆</td><td>Unknown</td></tr> </table> | 01 ₁₆ | Planned/preplot | 02 ₁₆ | Measured | 03 ₁₆ | Processed | 04 ₁₆ | Final | 0F ₁₆ | Unknown |
| 01 ₁₆ | Planned/preplot | | | | | | | | | | | |
| 02 ₁₆ | Measured | | | | | | | | | | | |
| 03 ₁₆ | Processed | | | | | | | | | | | |
| 04 ₁₆ | Final | | | | | | | | | | | |
| 0F ₁₆ | Unknown | | | | | | | | | | | |
| 32 | HT ₇ – HT ₀ | Header block type (one byte, unsigned binary). Set to 50 ₁₆ for Position Block 1. | | | | | | | | | | |

| INDEX BYTE | ABBREVIATION | DESCRIPTION |
|---------------|----------------------------------------|----------------------------------------------------------------------------------------------------------------------------------------------------------------------------------------------------------------------------------------------------------------------------------------------------------------------------------------------------------------------------------------|
| 33–40 | T1C1 ₆₃ – T1C1 ₀ | First coordinate for coordinate tuple 1 (eight bytes, IEEE double float). This coordinate and its unit is as given in the CRS definition in the location data stanza identified through ID1. Set to infinity (exponent all bits set, mantissa all zeroes) if CRS type is one-dimensional i.e. vertical. |
| 41–48 | T1C2 ₆₃ – T1C2 ₀ | Second coordinate for coordinate tuple 1 (eight bytes, IEEE double float). This coordinate and its unit is as given in the CRS definition in the location data stanza identified through ID1. Set to infinity (exponent all bits set, mantissa all zeroes) if CRS type is one-dimensional i.e. vertical. |
| 49–56 | T1C3 ₆₃ – T1C3 ₀ | Third coordinate for coordinate tuple 1 (eight bytes, IEEE double float). This coordinate and its unit is as given in the CRS definition in the location data stanza identified through ID1. Set to infinity (exponent all bits set, mantissa all zeroes) if CRS type is two-dimensional (projected or geographic 2D). |
| 57–58 | ID1 ₁₅ – ID1 ₀ | Location Data Stanza ID 1 (two bytes, unsigned binary). Location Data Stanza ID of the CRS for coordinate tuple 1. Defined in the Coordinate Reference System Identification blocks of the record header. Please refer to Appendix D for a description of the Coordinate Reference System Identification format. Range 0 to 65535. A value of 0 means unknown Location Data Stanza ID. |
| 59 | PV1 ₇ – PV1 ₀ | Position 1 Valid (one byte, unsigned binary). Position 1 valid flag. Set to 1 if position coordinates are valid, 0 if not. |
| 60 | PQ1 ₇ – PQ1 ₀ | Position 1 Quality (one byte, unsigned binary). Position 1 quality flag. Supported values: |

- 00₁₆ Position 1 not present
- 01₁₆ Position is good
- 02₁₆ Quality uncertain
- 03₁₆ Position is bad, not to be used

This field must always be filled in. The field will be an interpretation of VE, HEA, HEB and HEO (bytes 17–30) if available.

| | | |
|-------|-----------------------------------|----------------------------------------------------------------------------------------------|
| 61–63 | X | Undefined |
| 64 | HT ₇ – HT ₀ | Header block type (one byte, unsigned binary). Set to 51 ₁₆ for Position Block 2. |

| INDEX BYTE | ABBREVIATION | DESCRIPTION |
|---------------|----------------------------------------|-------------------------------------------------------------------------------------------------------------------------------------------------------------------------------------------------------------------------------------------------------------------------------------------------------------------------------------------------------------------------------------------------------------------------------------------------------------------|
| 65–72 | T2C1 ₆₃ – T2C1 ₀ | First coordinate for coordinate tuple 2 (eight bytes, IEEE double float). This coordinate and its unit is as given in the CRS definition in the location data stanza identified through ID2. Set to infinity (exponent all bits set, mantissa all zeroes) if CRS type is one-dimensional i.e. vertical. |
| 73–80 | T2C2 ₆₃ – T2C2 ₀ | Second coordinate for coordinate tuple 2 (eight bytes, IEEE double float). This coordinate and its unit is as given in the CRS definition in the location data stanza identified through ID2. Set to infinity (exponent all bits set, mantissa all zeroes) if CRS type is one-dimensional i.e. vertical. |
| 81–88 | T2C3 ₆₃ – T2C3 ₀ | Third coordinate for coordinate tuple 2 (eight bytes, IEEE double float). This coordinate and its unit is as given in the CRS definition in the location data stanza identified through ID2. Set to infinity (exponent all bits set, mantissa all zeroes) if CRS type is two-dimensional (projected or geographic 2D). |
| 89–90 | ID2 ₁₅ – ID2 ₀ | Location Data Stanza ID 2 (two bytes, unsigned binary). Location Data Stanza ID of the CRS for coordinate tuple 2. Defined in the Coordinate Reference System Identification blocks of the record header. Please refer to Appendix D for a description of the Coordinate Reference System Identification format. Range 0 to 65535. A value of 0 means unknown Location Data Stanza ID |
| 91 | PV2 ₇ – PV2 ₀ | Position 2 Valid (one byte, unsigned binary). Position 2 valid flag. Set to 1 if position coordinates are valid, 0 if not. |
| 92 | PQ2 ₇ – PQ2 ₀ | Position 2 Quality (one byte, unsigned binary). Position 2 quality flag. Supported values: <ul style="list-style-type: none"> 00₁₆ Position 2 not present 01₁₆ Position is good 02₁₆ Quality uncertain 03₁₆ Position is bad, not to be used This field must always be filled in. The field will be an interpretation of VE, HEA, HEB and HEO (bytes 17–30) if available. |
| 93–95 | X | Undefined |

8.14 RELATIVE POSITION BLOCK (optional)

The header block describes a position relative to the position described by the 96 byte position header. A textual description is included.

Relative offset is in projection/grid coordinates only. Follows directly after the position header to which it is relative. Multiple relative positions might be connected to the same position header, e.g. to describe the front and tail of source (Position Header describes center of source).

| INDEX BYTE | ABBREVIATION | DESCRIPTION |
|------------|------------------------------------|---------------------------------------------------------------------------------------------------------------------------------------------------------------------------------------------------------------------------------------------------------------------------------------------------------------------------------------------------|
| 1–4 | OE ₃₁ – OE ₀ | Offset Easting (four bytes, IEEE float). Offset in projected (grid) coordinates in easting direction, in units given in projected CRS definition. Note that (i) although given first here, easting may not be the first coordinate given in Position Header block, (ii) SEG-D only allows horizontal offsets to be given in projected terms. |
| 5–8 | ON ₃₁ – ON ₀ | Offset Northing (four bytes, IEEE float). Offset in projected (grid) coordinates in northing direction, in units given in projected CRS definition. Note that (i) although given second here, northing may not be the second coordinate given in Position Header block, (ii) SEG-D only allows horizontal offsets to be given in projected terms. |
| 9–12 | OD ₃₁ – OD ₀ | Offset Vertical (four bytes, IEEE float). Offset in vertical direction, in units given in vertical CRS definition. Note that whether a positive offset is a height or a depth is defined in the CRS Header. |
| 13–31 | DE | Description (19 bytes, ASCII text). Manufacturer defined, textual description of the equipment. Left justified, padded with space (ASCII 20 ₁₆). |
| 32 | HT ₇ – HT ₀ | Header block type (one byte, unsigned binary). Set to 56 ₁₆ for Relative Position Block. |

8.15 SCAN TYPE HEADER (channel set descriptor)

The scan type header is determined by the system configuration and consists of one or more channel set descriptors each of 96 bytes followed by a series of 32 byte sample skew fields. A channel set is defined as a group of channels operating with the same set of parameters and being sampled as part of a scan of data. A scan type header can be composed of from 1 to 65535 channel set descriptors. If dynamic parameter changes are required during the recording, additional scan

type headers must be added, each containing the channel set descriptors necessary to define the new parameters. Each scan type header must have the same number of channel set descriptors.

8.16 CHANNEL SET DESCRIPTOR

| INDEX BYTE | ABBREVIATION | DESCRIPTION |
|---------------|------------------------------------|------------------------------------------------------------------------------------------------------------------------------------------------------------------------------------------------------------------------------------------------------------------------------------------------------------------------------------------------------------------------------------------------------------------------------------------------------------------------------------------------------------------------------------------------------------------------------------------------------------------------------------------------------------------------------------------------------------------------------------------------------------------------------------------------------------------------------------------------------------------------------------------------------------------------------------------------------------------------------------------------------------------------------------------------------------------------------------------------------------------------------------------------------------------------------------------------------------------------------|
| 1 | ST ₁ , ST ₂ | These two digits (one byte BCD) (1–99) identify the number of the scan type header to be described by the subsequent bytes. The first scan type header is 1 and the last scan type header number is the same value as Byte 28 (ST/R) of the General Header Block #1. If a scan type header contains more than one channel set descriptor, the scan type header number will be repeated in each of its channel set descriptors. If the system does not have dynamic parameter changes during the record, such as switched sampling intervals, there will only be one scan type header required. |
| 2,3 | CS ₁₅ – CS ₀ | Channel Set Number (two bytes, unsigned binary). These digits (1–65535) identify the channel set to be described in the next 94 bytes within this scan type header. The first channel set is "1" and the last channel set number is the same number as Byte 29 (CS) of the General Header Block #1 (or bytes 4-5 (EN) of General Header #2 if Extended Channel Sets/Scan Type is used). If the scan actually contains fewer channel sets than CS, then dummy channel set descriptors are included as specified in Byte 29 of General Header Block #1 / bytes 4-5 of General Header #2. |
| 4 | C ₇ – C ₀ | Channel type Identification (one byte, unsigned binary). <ul style="list-style-type: none"> 00₁₆ Unused 10₁₆ Seis 11₁₆ Electromagnetic (EM) 20₁₆ Time break 21₁₆ Clock timebreak 22₁₆ Field timebreak 30₁₆ Up hole 40₁₆ Water break 50₁₆ Time counter 60₁₆ External Data 61₁₆ Acoustic range measurement 62₁₆ Acoustic reference measured (correlation reference) 63₁₆ Acoustic reference nominal (correlation reference) 70₁₆ Other 80₁₆ Signature/unfiltered 90₁₆ Signature/filtered 91₁₆ Source signature/unfiltered 92₁₆ Source signature/filtered 93₁₆ Source signature/estimated 94₁₆ Source signature/measured 95₁₆ Source base plate 96₁₆ Source reference sweep 97₁₆ Source other 98₁₆ Source reference pilot |

| | |
|------------------|----------------------------------------------|
| 99 ₁₆ | Source mass |
| A0 ₁₆ | Auxiliary Data Trailer (no longer used) |
| B0 ₁₆ | True reference sweep (correlation reference) |
| B1 ₁₆ | Radio reference sweep |
| B2 ₁₆ | Radio similarity signal |
| B3 ₁₆ | Wireline reference sweep |
| C0 ₁₆ | Depth |
| C1 ₁₆ | Wind |
| C2 ₁₆ | Current |
| C3 ₁₆ | Voltage |
| C4 ₁₆ | Velocity |
| C5 ₁₆ | Acceleration |
| C6 ₁₆ | Pressure |
| C7 ₁₆ | Tension |
| C8 ₁₆ | Tilt measurement |
| C9 ₁₆ | Angle measurement |
| F0 ₁₆ | Calibration trace (time series) |

5-8 TF₃₁ – TF₀ Channel set start time (four bytes, two's complement, signed binary). This is a microsecond (1/1000000 second) unit of measurement. This number identifies the timing word of the first scan of data in this channel set. In a single scan type record, this would typically be recorded as a zero (an exception might be deep water recording). In multiple scan type records, this number represents the starting time, in microseconds, of the channel set. Start times from -2,147,483,648 to 2,147,483,647 (in 1-μsec increments) can be recorded. In Extended Recording mode (byte 29 of General Header #3 set to 1) this field is not used, and should be set to 0. By setting TF and TE to 0, the manufacturer can use a Timestamp Header in each trace to allow recording data over a larger time span than the normal +/- 2147 seconds even without utilizing the Extended Recording Mode (i.e. byte 29 of General Header #3 set to 0). This also allows recording traces with different start points within the same channelset. Note: All other limitations on channel sets as defined in section "5.2 Scan Type Headers" still applies. Also note: TF and TE *must* be set to 0 if a Timestamp header is used to indicate trace start time.

9-12 TE₃₁ – TE₀ Channel set end time (four bytes, two's complement, signed binary). This is a microsecond (1/1000000 second) unit of measurement. This number represent the record end time of the channel set in microseconds. TE may be used to allow the termination of a particular channel set shorter than other channel sets within its scan type. In a single scan type record starting at time zero, Bytes 9-12 would be the length of the record. End times from -2,147,483,648 to 2,147,483,647 μsec (in 1-μsec increments) can be recorded. In Extended Recording mode (byte 29 of General Header #3 set to 1) this field is not used, and should be set to 0. By setting TF and TE to 0, the manufacturer can use a Timestamp Header in each trace to allow recording data over a larger time span than the normal +/- 2147 seconds even without utilizing the Extended Recording Mode (i.e. byte 29 of General Header #3 set to 0). This also allows recording traces with different start points within the same channelset. Note: All other limitations on channel sets as defined in section "5.2 Scan Type Headers" still applies. Also note: TF and TE *must* be set to 0 if a Timestamp header is used to

indicate trace start time.

| | | | | | | | | | | | | | | |
|-----------|--------------------------------------------|-----------------------------------------------------------------------------------------------------------------------------------------------------------------------------------------------------------------------------------------------------------------------------------------------------------------------------------------------------------------------------------------------------------------------------------------------------------------------------------------------------------------------------------------------------------------------------------------------------------------------------------------------------------------------------------------------|-----------|-------------------|-----------|--------------------------------|-----------|--------------------------------|-----------|--------------------------------|-----------|--------------------------------|-----------|--------------------------------------------|
| 13–16 | $NS_{31} - NS_0$ | Number of samples in each trace of this channel set (four bytes, unsigned binary). It can assume a value from 0 to 4,294,967,295. For the purpose of this SEG-D standard, the number of samples NS, sampling interval SR, channel set start time TF, and channel set end time TE should be related by the formula $TE=TF+NS\times SR$. | | | | | | | | | | | | |
| 17–20 | $DSM_{31} - DSM_0$ | Sample descale multiplication factor (four bytes, IEEE float). The multiplier is be used to descale the data on tape to obtain input voltage in millivolts. | | | | | | | | | | | | |
| 21–23 | $C/S_{23} - C/S_0$ | Number of channels in this channel set (three bytes, unsigned binary). It can assume a value from 0 to 16,777,215. | | | | | | | | | | | | |
| 24–26 | $SR_{23} - SR_0$ | Sampling Interval (three bytes, unsigned binary). This is a microsecond (1/1000000 second) unit of measurement. It can assume a value from 0 to 16,777,215. | | | | | | | | | | | | |
| 27 | $ARY_7 - ARY_0$ | <p>Array Forming (one byte, unsigned binary). Identifies whether the data in this channel set is the result of array forming.</p> <table border="0" style="margin-left: 40px;"> <tr> <td>01_{16}</td> <td>No array forming.</td> </tr> <tr> <td>02_{16}</td> <td>2 groups summed, no weighting.</td> </tr> <tr> <td>03_{16}</td> <td>3 groups summed, no weighting.</td> </tr> <tr> <td>04_{16}</td> <td>4 groups summed, no weighting.</td> </tr> <tr> <td>$0N_{16}$</td> <td>N groups summed, no weighting.</td> </tr> <tr> <td>$1N_{16}$</td> <td>N groups weighted, overlapping, summation.</td> </tr> </table> | 01_{16} | No array forming. | 02_{16} | 2 groups summed, no weighting. | 03_{16} | 3 groups summed, no weighting. | 04_{16} | 4 groups summed, no weighting. | $0N_{16}$ | N groups summed, no weighting. | $1N_{16}$ | N groups weighted, overlapping, summation. |
| 01_{16} | No array forming. | | | | | | | | | | | | | |
| 02_{16} | 2 groups summed, no weighting. | | | | | | | | | | | | | |
| 03_{16} | 3 groups summed, no weighting. | | | | | | | | | | | | | |
| 04_{16} | 4 groups summed, no weighting. | | | | | | | | | | | | | |
| $0N_{16}$ | N groups summed, no weighting. | | | | | | | | | | | | | |
| $1N_{16}$ | N groups weighted, overlapping, summation. | | | | | | | | | | | | | |
| 28 | $THE_7 - THE_0$ | Number of Trace Header Extensions (one byte, unsigned binary). Must match byte 10 of the Demux Trace Header. Range 1-255. 0 is not allowed. | | | | | | | | | | | | |
| 29 | $EFH_3 - EFH_0$, | Extended Header flag (half byte, unsigned binary). Set to 1 to indicate that the extended header contains additional information on the channel set. | | | | | | | | | | | | |
| 29 | J | <p>Channel gain control method (half byte, unsigned binary).</p> <table border="0" style="margin-left: 40px;"> <tr> <td>1_{16}</td> <td>Individual AGC</td> </tr> <tr> <td>2_{16}</td> <td>Ganged AGC</td> </tr> <tr> <td>3_{16}</td> <td>Fixed gain</td> </tr> <tr> <td>4_{16}</td> <td>Programmed gain</td> </tr> <tr> <td>8_{16}</td> <td>Binary gain control</td> </tr> <tr> <td>9_{16}</td> <td>IFP gain control</td> </tr> </table> | 1_{16} | Individual AGC | 2_{16} | Ganged AGC | 3_{16} | Fixed gain | 4_{16} | Programmed gain | 8_{16} | Binary gain control | 9_{16} | IFP gain control |
| 1_{16} | Individual AGC | | | | | | | | | | | | | |
| 2_{16} | Ganged AGC | | | | | | | | | | | | | |
| 3_{16} | Fixed gain | | | | | | | | | | | | | |
| 4_{16} | Programmed gain | | | | | | | | | | | | | |
| 8_{16} | Binary gain control | | | | | | | | | | | | | |
| 9_{16} | IFP gain control | | | | | | | | | | | | | |
| 30 | $VS_7 - VS_0$ | Vertical Stack (one byte, unsigned binary). Effective stack order. Set to zero if the trace data was intentionally set to real zero. Set to one if no stack. Set to the effective stack order if the data is the result of stacked data (with or without processing). | | | | | | | | | | | | |

| | | |
|-------|--------------------------------------|---------------------------------------------------------------------------------------------------------------------------------------------------------------------------------------------------------------------------------------------------------------------------------------------------------------------------|
| 31 | CAB ₇ – CAB ₀ | Streamer Cable number (one byte, unsigned binary). Required for streamer data only. Identifies the number of the streamer cable that will be identified in this block. The starboard-most cable is identified as cable 1 while the Port most cable is N. Zero means that the Streamer Cable number has not been recorded. |
| 32 | HT ₇ – HT ₀ | Header block type (one byte, unsigned binary). Set to 30 ₁₆ for Channel Set Descriptor block 1. |
| 33–36 | AF ₃₁ – AF ₀ | Alias filter frequency in Hz (four bytes, IEEE float). |
| 37–40 | LC ₃₁ – LC ₀ | Low-cut filter setting in Hz (four bytes, IEEE float). |
| 41–44 | AS ₃₁ – AS ₀ | Alias filter slope in dB per octave (four bytes, IEEE float). A zero indicates the filter is out. (See Appendix E3 for definition.) |
| 45–48 | LS ₃₁ – LS ₀ | Low-cut filter slope (four bytes, IEEE float). A zero indicates the filter is out. (See Appendix E3 for definition.) |
| 49–52 | NT ₁₃₁ – NT ₁₀ | Notch frequency setting (four bytes, IEEE float). The out filter is written as 0.0 Hz. |

The following notch filters are coded in a similar manner:

| | | |
|-------|--------------------------------------|---------------------------------------------------------------------------------------------------------------------------------------------------------------------------------------------------------------------------------------------------------------------------------------------------------------------------------------------------------------------------------------------------------------------------------------------------------------------------------------------------------------------------------------------------------------------------------------------------------|
| 53–56 | NT ₂₃₁ – NT ₂₀ | Second notch frequency |
| 57–60 | NT ₃₃₁ – NT ₃₀ | Third notch frequency |
| 61 | FPH ₇ – FPH ₀ | Filter phase (one byte, unsigned binary). 00 ₁₆ Unknown 01 ₁₆ Minimum 02 ₁₆ Linear 03 ₁₆ Zero 04 ₁₆ Mixed 05 ₁₆ Maximum |
| 62 | PHU ₇ – PHU ₀ | Physical unit (one byte, unsigned binary). This is the physical unit measured by this sensor. 00 ₁₆ Unknown 01 ₁₆ Millibar 02 ₁₆ Bar 03 ₁₆ Millimeter/second 04 ₁₆ Meter/second 05 ₁₆ Millimeter/second/second 06 ₁₆ Meter/second/second 07 ₁₆ Newton 08 ₁₆ Kelvin 09 ₁₆ Hertz 0A ₁₆ Second 0B ₁₆ Tesla 0C ₁₆ Volt/meter 0D ₁₆ Volt meter 0E ₁₆ Ampere/meter 0F ₁₆ Volt |

10₁₆ Ampere
 11₁₆ Radians (angle)

| | | |
|-------|--------------------------------------|------------------------------------------------------------------------------------------------------------------------------------------------------------------------------------------------------------------------------------------|
| 63 | X | These bits are undefined by the format and may have any value. Note: In future versions these may be defined, so use with caution. |
| 64 | HT ₇ – HT ₀ | Header block type (one byte, unsigned binary). Set to 31 ₁₆ for Channel Set Description block 2. |
| 65–68 | FDL ₃₁ – FDL ₀ | Filter delay (four bytes, unsigned binary). The signal delay introduced by the filter in microseconds. |
| 69–95 | DSC | Description (27 bytes, ASCII text). Channel set description 27 byte free-text as defined by the recording system. Left justified, padded with spaces (20 ₁₆) for unused characters. zero (00 ₁₆) is not allowed. |
| 96 | HT ₇ – HT ₀ | Header block type (one byte, unsigned binary). Set to 32 ₁₆ for Channel Set Descriptor block 3. |

8.17 DEMUX TRACE HEADER

| INDEX BYTE | ABBREVIATION | DESCRIPTION |
|---------------|-------------------------------------|----------------------------------------------------------------------------------------------------------------------------------------------------------------------------------------------------------------------------------------------------------------------------------------------------------------------------------------------------------------------------------------|
| 1,2 | F ₁ – F ₄ | File Number (two bytes, four digits, BCD). These bytes must be set to FFFF ₁₆ when the file number is above 9999, i.e. the Extended File Number (bytes 18–20) is used. |
| 3 | ST ₁ – ST ₂ | Scan Type Number (one byte, two digits, BCD). (1-99) Scantype this trace belongs to, see Channel Set Descriptor byte 1. |
| 4 | CN ₁ – CN ₂ | Channel Set Number (one byte, two digits, BCD). (1-9999) Channel Set this trace belongs to, see Channel Set Descriptor byte 2-3. Set to FF ₁₆ if more than 99 channel sets are required, i.e. Extended Channel Set Number (byte 16–17) is used. |
| 5,6 | TN ₁ – TN ₄ | Trace Number (two bytes, four digits, BCD). (1-9999) Set to FFFF ₁₆ if more than 9999 channels are required, i.e. Extended Trace Number (byte 22–24 of Trace Header Extension) is used. |
| 7–9 | T ₁₅ – T ₈ | First Timing Word. (signed binary, two bytes integer, one byte fractional). These bytes comprise the timing word that would accompany the first sample if these data were written in the multiplexed format. To obtain the exact sample timing, the actual sample skew time (byte 11 multiplied by the Channel Set Sampling Interval) must be added to the time recorded in Bytes 7–9. |
| 10 | THE ₇ – THE ₀ | Trace Header Extensions (one byte, unsigned binary). Indicates the number of Trace Header Extension blocks (32 bytes each). Range 1-255. At least one Trace Header Extension block (the Trace Header Extension, block type 40 ₁₆) is required. Channels within the same channel set must have the same number of |

| | | |
|-------|---------------------------------------|---------------------------------------------------------------------------------------------------------------------------------------------------------------------------------------------------------------------------------------------------------------------------------------------------------------------------------------------------------------------------------------------------------------------------------------------|
| | | Trace Header Extensions. Value must be the same as byte 28 of the matching Channel Set Descriptor. |
| 11 | SSK ₋₁ – SSK ₋₈ | Sample Skew (one byte, binary fraction). The fractional skew value represents the fractional part of the Channel Set Sampling Interval (Byte 24-26 of Channel Set Descriptor.) |
| 12 | TR ₇ – TR ₀ | Trace edit (one byte, unsigned binary). 00 ₁₆ No edit applied to this trace. 01 ₁₆ Trace part of dead channels for roll-on or roll-off spread. Trace intentionally zeroed. 02 ₁₆ Trace intentionally zeroed. 03 ₁₆ Trace has been edited. This flag will indicate that the acquisition system has modified one or more samples of this trace. Other codes are undefined in Rev 3.0. |
| 13–15 | TW ₁₅ – TW ₋₈ | Time Break Window (three bytes, unsigned binary with two bytes integer and one byte fraction). Bytes 13, 14, and 15 are included as an integrity check on time break. They comprise the timing word of the scan in which TWI changed to a one. |
| 16,17 | EN ₁₅ – EN ₀ | Extended Channel Set Number (two bytes, unsigned binary). Allows Channel Set Numbers beyond the 99 which can be indicated in byte 4. To allow Channel Set Numbers greater than 99, or to allow use of a binary channel set number, set byte 4 to FF ₁₆ and use bytes 16 and 17 for the Channel Set Number. |
| 18–20 | EFN ₂₃ – EFN ₀ | Extended File Number (three bytes, unsigned binary). Allows File Numbers beyond the 9999 which can be indicated in bytes 1 and 2. To allow File Numbers greater than 9999, or to allow use of a binary file numbers, set bytes 1 and 2 to FFFF ₁₆ and use bytes 18, 19, and 20 for the File Number. |

8.18 TRACE HEADER EXTENSION #1

| INDEX BYTE | ABBREVIATION | DESCRIPTION |
|---------------|--------------------------------------|-----------------------------------------------------------------------------------------------------------------------------------------------------------------------------------------------------------------------------------------------------------------------------------------------------------------------------------------------------------------------------------------------------------|
| 1–3 | RLN ₂₃ – RLN ₀ | Receiver Line Number (three bytes, two's complement, signed binary). |
| 4–6 | RPN ₂₃ – RPN ₀ | Receiver Point Number (three bytes, two's complement, signed binary). |
| 7 | RPI ₇ – RPI ₀ | Receiver Point Index (one byte, two's complement, signed binary). This index allows several locations for the receiver group in the grid, the original value is 1 and that value is incremented by 1 every time the receiver is moved, even when it is moved back to the previous location). Receiver Point Index may also be used for downhole seismic to extend the numerical range of the Depth Index. |
| 8 | RI ₇ – RI ₀ | Re-shoot Index (one byte, unsigned binary). The re-shoot index is used to indicate that this receiver has been moved back here for a re-acquisition (shot |

has been recorded earlier, and this record should replace it). Re-shoot index starts at 0 (indicates recorded for first time).

| | | | | | | | | | | | | | | | | | | | | | | | | | | | | |
|-----------|--------------------------------------|---------------------------------------------------------------------------------------------------------------------------------------------------------------------------------------------------------------------------------------------------------------------------------------------------------------------------------------------------------------------------------------------------------------------------------------------------------------------------------------------------------------------------------------------------------------------------------------------------------------------------------------------------------------------------------------------------------------------------------------------------------------------------------------------------------------------------------------------------------------------------------------------------------------------------------------------------------------------------------------------------------------------------------------------------------------------------------------------------------------------------------------------------------------------------|-----------|-------------|-----------|------------------------------|-----------|-------------------------------------|-----------|------------------------------|-----------|----------------------------------|-----------|-----------------------------|-----------|-------------------------|-----------|-----------------------------------|-----------|--------------------------------------|-----------|----------------------------------|------|--|-----------|-----------------|-----------|---------------|
| 9 | $GI_7 - GI_0$ | Group Index (one byte, unsigned binary). Group index is used to indicate this receiver is part of a set of receivers needed to be processed as a unit. This could be a component of a three-component sensor at a given location. 0 means receiver is not part of a group. | | | | | | | | | | | | | | | | | | | | | | | | | | |
| 10 | $DI_7 - DI_0$ | Depth Index (one byte, unsigned binary). The depth index is used to indicate receivers recorded at different depths on the same location. 0 is not allowed. Starts at 1 closest to the surface, and counts up when moving downwards. | | | | | | | | | | | | | | | | | | | | | | | | | | |
| 11–15 | $ERLN_{23} - ERLN_{-16}$ | Extended Receiver Line Number (Signed binary, three bytes integer, two bytes fractional). Allows fractional Receiver Line Numbers. Only valid if bytes 1–3 in this Trace Header Extension are set to $FFFFFF_{16}$. The representation of a negative receiver line number is the two's complement of the integer formed by multiplying the absolute value of the receiver line number by 65536. | | | | | | | | | | | | | | | | | | | | | | | | | | |
| 16–20 | $ERP_{23} - ERP_{-16}$ | Extended Receiver Point Number (Signed binary, three bytes integer, two bytes fractional). Allows fractional Receiver Point Numbers. Only valid if bytes 4–6 in this Trace Header Extension are set to $FFFFFF_{16}$. The representation of a negative receiver line number is the two's complement of the integer formed by multiplying the absolute value of the receiver line number by 65536. | | | | | | | | | | | | | | | | | | | | | | | | | | |
| 21 | $SEN_7 - SEN_0$ | <p>Sensor Type recorded on this trace (one byte, unsigned binary)</p> <table border="0" style="margin-left: 40px;"> <tr><td>00_{16}</td><td>Not defined</td></tr> <tr><td>01_{16}</td><td>Hydrophone (pressure sensor)</td></tr> <tr><td>02_{16}</td><td>Geophone (velocity sensor) Vertical</td></tr> <tr><td>03_{16}</td><td>Geophone, Horizontal, inline</td></tr> <tr><td>04_{16}</td><td>Geophone, Horizontal, cross-line</td></tr> <tr><td>05_{16}</td><td>Geophone, Horizontal, other</td></tr> <tr><td>06_{16}</td><td>Accelerometer, Vertical</td></tr> <tr><td>07_{16}</td><td>Accelerometer, Horizontal, inline</td></tr> <tr><td>08_{16}</td><td>Accelerometer, Horizontal, crossline</td></tr> <tr><td>09_{16}</td><td>Accelerometer, Horizontal, other</td></tr> <tr><td> </td><td></td></tr> <tr><td>15_{16}</td><td>Electric Dipole</td></tr> <tr><td>16_{16}</td><td>Magnetic coil</td></tr> </table> <p style="margin-left: 40px;">other values are not defined at the present time</p> | 00_{16} | Not defined | 01_{16} | Hydrophone (pressure sensor) | 02_{16} | Geophone (velocity sensor) Vertical | 03_{16} | Geophone, Horizontal, inline | 04_{16} | Geophone, Horizontal, cross-line | 05_{16} | Geophone, Horizontal, other | 06_{16} | Accelerometer, Vertical | 07_{16} | Accelerometer, Horizontal, inline | 08_{16} | Accelerometer, Horizontal, crossline | 09_{16} | Accelerometer, Horizontal, other | | | 15_{16} | Electric Dipole | 16_{16} | Magnetic coil |
| 00_{16} | Not defined | | | | | | | | | | | | | | | | | | | | | | | | | | | |
| 01_{16} | Hydrophone (pressure sensor) | | | | | | | | | | | | | | | | | | | | | | | | | | | |
| 02_{16} | Geophone (velocity sensor) Vertical | | | | | | | | | | | | | | | | | | | | | | | | | | | |
| 03_{16} | Geophone, Horizontal, inline | | | | | | | | | | | | | | | | | | | | | | | | | | | |
| 04_{16} | Geophone, Horizontal, cross-line | | | | | | | | | | | | | | | | | | | | | | | | | | | |
| 05_{16} | Geophone, Horizontal, other | | | | | | | | | | | | | | | | | | | | | | | | | | | |
| 06_{16} | Accelerometer, Vertical | | | | | | | | | | | | | | | | | | | | | | | | | | | |
| 07_{16} | Accelerometer, Horizontal, inline | | | | | | | | | | | | | | | | | | | | | | | | | | | |
| 08_{16} | Accelerometer, Horizontal, crossline | | | | | | | | | | | | | | | | | | | | | | | | | | | |
| 09_{16} | Accelerometer, Horizontal, other | | | | | | | | | | | | | | | | | | | | | | | | | | | |
| | | | | | | | | | | | | | | | | | | | | | | | | | | | | |
| 15_{16} | Electric Dipole | | | | | | | | | | | | | | | | | | | | | | | | | | | |
| 16_{16} | Magnetic coil | | | | | | | | | | | | | | | | | | | | | | | | | | | |
| 22–24 | $ETN_{23} - ETN_0$ | Extended Trace Number (three bytes, unsigned binary). Extended trace number to allow up to 16,777,215 traces in one channel set. Field is only valid if bytes 5–6 in Demux Trace Header is set to $FFFF_{16}$. | | | | | | | | | | | | | | | | | | | | | | | | | | |
| 25–28 | $NS_{31} - NS_0$ | Number of samples in this trace (four bytes, unsigned binary) It can assume a value from 0 to 4,294,967,295. This must be the same as bytes 13–16 of channel set descriptor. | | | | | | | | | | | | | | | | | | | | | | | | | | |
| 29 | $MV_7 - MV_0$ | Sensor moving (one byte, unsigned binary). Sensor moving or stationary. Set to 1 if sensor is moving during the record, 0 if it is stationary. | | | | | | | | | | | | | | | | | | | | | | | | | | |
| 30 | X | Undefined | | | | | | | | | | | | | | | | | | | | | | | | | | |

| | | |
|----|-------------------------------------|---------------------------------------------------------------------------------------------------------------------------------------|
| 31 | PHU ₇ – PHU ₀ | Physical unit (1 byte, unsigned binary). This is the physical unit measured by this sensor. Same as byte 62 of the channel set header |
| 32 | HT ₇ – HT ₀ | Header block type (1 byte, unsigned binary) Set to 40 ₁₆ for Trace header extension 1. |

8.19 SENSOR INFO HEADER EXTENSION (optional)

| INDEX BYTE | ABBREVIATION | DESCRIPTION |
|------------|--------------------------------------|----------------------------------------------------------------------------------------------------------------------------------------------------------------------------------------------------------------------------------------------|
| 1–8 | ITT ₆₃ – ITT ₀ | Equipment Test Time (SEG-D 8 byte timestamp). Time of last test. Set to 0 if not recorded. |
| 9–12 | STY ₃₁ – STY ₀ | Sensor Sensitivity (four bytes, IEEE float). This is the signal sensitivity for the sensor. Divide the sample value by this number to achieve a physical unit (as specified in bytes 31). Set to 0 if not specified (physical unit unknown). |
| 13 | ITR ₇ – ITR ₀ | Equipment Test Result (one byte, unsigned binary). The following values are allowed 00 ₁₆ Unknown (untested) 01 ₁₆ Passed 02 ₁₆ Failed 03 ₁₆ Uncertain (warning during IT) |
| 14–31 | SN | Serial Number (18 bytes, ASCII text) . Serial number of sensor for this receiver. Left-justified, padded with space (20 ₁₆) characters. |
| 32 | HT ₇ – HT ₀ | Header block type (one byte, unsigned binary). Set to 41 ₁₆ for Sensor Info Header Extension. |

8.20 TIMESTAMP HEADER (optional)

| INDEX BYTE | ABBREVIATION | DESCRIPTION |
|------------|--------------------------------------|--------------------------------------------------------------------------------------------------------------------------------------------------------------------------------------------------------------------------------------------------------------------------------------------------------------------------------------------------------------------------------------------------------------------------------------------------------------------------------------------------------------------------------------------------------|
| 1–8 | TZD ₆₃ – TZD ₀ | Time Zero for this data block (eight bytes, SEG-D timestamp). The time of first sample in the data described by this header. (The actual sample time is calculated as Time Zero + Sample Skew + First Timing Word.) Typically inserted into Trace Header in Extended Recording Mode, the timestamp is then the time of first sample in the trace. If the recorder does not know the absolute time, this timestamp must be relative to the timestamp in General Header Block #3 (bytes 1–8), i.e. number of microseconds since time zero of the record. |

| | | |
|------|-----------------------------------|---------------------------------------------------------------------------------------------------------------------------------------------------------------------------------------------------------------------------|
| 9–31 | X | These byte fields are undefined by the format and may have any value. Note: In future versions these may be defined, so use with caution. |
| 32 | HT ₇ – HT ₀ | Header block type (one byte, unsigned binary). The header type indicates what type of information is contained in this header. See Table 2 for an overview of header types. Set to 42 ₁₆ for Timestamp Header. |

8.21 SENSOR CALIBRATION HEADER (optional)

Use of the sensor calibration header supports between 1 and a maximum of approximately 500 points (the maximum size of the trace header). The maximum depends on what other blocks are present in the trace header. If a higher resolution calibration is required, a calibration channel/channelset must be created.

| INDEX BYTE | ABBREVIATION | DESCRIPTION |
|---------------|--------------------------------------|--------------------------------------------------------------------------------------------------------------------------------------------------------------------------------------------------------------------------------------------------------------------------------------------------------------------------------------------------------------------------------|
| 1–4 | FR1 ₃₁ – FR1 ₀ | Frequency 1 (four bytes, IEEE float). The frequency of first calibration value. Set to 0.0 if not used. |
| 5–8 | AM1 ₃₁ – AM1 ₀ | Amplitude 1 (four bytes, IEEE float). The amplitude of first calibration value. |
| 9–12 | PH1 ₃₁ – PH1 ₀ | Phase 1 (four bytes, IEEE float). The phase of first calibration value. |
| 13–16 | FR2 ₃₁ – FR2 ₀ | Frequency 2 (four bytes, IEEE float). The frequency of second calibration value. Set to 0.0 if not used. |
| 17–20 | AM2 ₃₁ – AM2 ₀ | Amplitude 2 (four bytes, IEEE float). The amplitude of second calibration value. |
| 21–24 | PH2 ₃₁ – PH2 ₀ | Phase 2 (four bytes, IEEE float). The phase of second calibration value. |
| 25 | CA ₇ – CA ₀ | Calibration applied (one byte, unsigned binary). Set to 1 if calibration has already been applied, i.e. the trace has been corrected with the calibration function described by the values in the Sensor Calibration Header blocks, set to 0 if trace is not corrected. Note: Multiple Sensor Calibration Header blocks are usually needed to describe a calibration function. |
| 26–31 | X | Undefined |
| 32 | HT ₇ – HT ₀ | Header block type (one byte, unsigned binary). The header type indicates what type of information is contained in this header. See Table 2 for an overview of header types. Set to 43 ₁₆ for Sensor Calibration Header. |

8.22 TIME DRIFT HEADER (optional)

This block may be used when data from sensors with drifting clocks are merged into one SEG-D record. Data must be clock drift corrected prior to creating a SEG-D shot, i.e. SEG-D only supports recording data with one single clock reference system.

| INDEX BYTE | ABBREVIATION | DESCRIPTION |
|---------------|-------------------------------------|-----------------------------------------------------------------------------------------------------------------------------------------------------------------------------------------------------------------------------------------------------------------------------------------------------------------------------------------------------------------------------------|
| 1–8 | TD ₆₃ – TD ₀ | Time of deployment (eight bytes, SEG-D timestamp). Time of sensor unit deployment, i.e. when time drift was measured before deployment. |
| 9–16 | TR ₆₃ – TR ₀ | Time of retrieval (eight bytes, SEG-D timestamp). Time of sensor unit retrieval, i.e. when the time drift was measured after retrieval. |
| 17–20 | OD ₃₁ – OD ₀ | Time offset at deployment (four bytes, two's complement, signed binary). Time offset value at deployment in number of microseconds. Range approximately ±2147 seconds. |
| 21–24 | OR ₃₁ – OR ₀ | Time offset at retrieval (four bytes, two's complement, signed binary). Time offset value at retrieval in number of microseconds. Range approximately ±2147 seconds. |
| 25 | TDC ₇ – TDC ₀ | Time drift corrected (one byte, unsigned binary). Set to 1 if time drift correction has been applied, 0 if not. Note: SEG-D only supports recording data from one clock reference system. <i>Data must be time drift corrected prior to record creation if data acquired from sensors with decoupled (drifting) clocks is merged into one SEG-D record.</i> |
| 26 | CM ₇ – CM ₀ | Time drift correction method (one byte, unsigned binary). Method used to correct for time drift. The following methods are supported: <ul style="list-style-type: none"> 00₁₆ Uncorrected 01₁₆ Linear correction (values in this header used) FF₁₆ Other, manufacturer defined method used for correction |
| 27–31 | X | Undefined |
| 32 | HT ₇ – HT ₀ | Header block type (one byte, unsigned binary). Set to 44 ₁₆ for Time Drift Header. |

8.23 ORIENTATION HEADER (optional)

The orientation header provides the means to specify the orientation at a given position for 3C data.

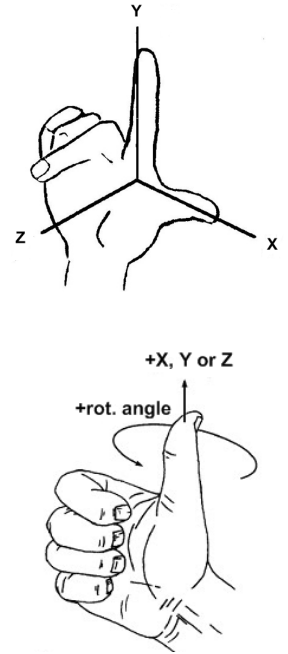
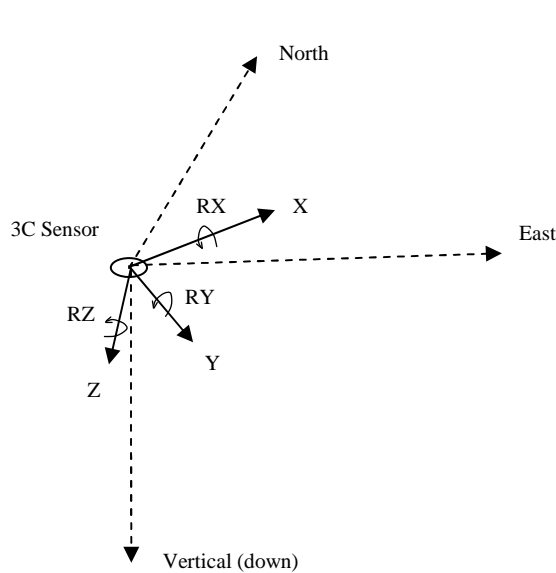

Figure shows multicomponent measurements and their respective rotation measurements relative to the reference system (north/east/vertical)

X is defined as in-line, Y is cross-line and Z is vertical. Positive vertical is down. The rotation follows the right-hand rule. RX is defined as rotation around X axis, RY around Y axis, and RZ around Z axis. Positive value as defined by right-hand rule. This means the axis and positive direction for the rotation angles around the axis are given by the right hand, as indicated in the figures above.

X axis will for cable acquisition (towed streamers, seabed cables etc.) be along the cable.

The rotation measurement in the sensor is expected to result in a rotation to the horizontal plane, however rotation to true north will in many cases require an external measurement. This value is hence extracted to a separate field in the rotation header, and may also be recorded as 0 if not available at the time of acquisition.

$$\begin{bmatrix} C_{north} \\ C_{east} \\ C_{vertical} \end{bmatrix} = \begin{bmatrix} R_{11} & R_{12} & R_{13} \\ R_{21} & R_{22} & R_{23} \\ R_{31} & R_{32} & R_{33} \end{bmatrix} * \begin{bmatrix} C_x \\ C_y \\ C_z \end{bmatrix} \quad (1)$$

The rotation described in bytes 1–16 in the orientation header must fulfill equation (1) above. The group index for multicomponent data must hence be numbered such that

- 1 = X axis
- 2 = Y axis
- 3 = Z axis

| INDEX BYTE | ABBREVIATION | DESCRIPTION |
|------------|------------------------------------|-----------------------------------------------------------------------|
| 1–4 | RX ₃₁ – RX ₀ | Rotation angle around the X axis in radians (four bytes, IEEE float). |
| 5–8 | RY ₃₁ – RY ₀ | Rotation angle around the Y axis in radians (four bytes, IEEE float). |

| | | |
|-------|-------------------------------------|-------------------------------------------------------------------------------------------------------------------------------------------------------------------------------------------------------------------------------------------------------------------------------------------------------------------------------------------------------------------------------------------------------------------------------------------------------------------------------------------------------------------------------------------------------------------------------------------------------------|
| 9–12 | RZ ₃₁ – RZ ₀ | Rotation angle around the Z axis in radians (four bytes, IEEE float). |
| 13–16 | RO ₃₁ – RO ₀ | Reference Orientation (four bytes, IEEE float). Rotation angle for the system described in bytes 1–12 relative to true north, i.e. the rotation angle around the Z axis for the X direction to point towards true north, This will be the cable direction or housing orientation, depending of the value of byte 25. Recorded as 0 if not applicable. If value is valid, byte 26 should be set to 1. May be recorded as 0 if the value is unknown at the time of recording. The value must then be made available to the processing/QC systems through other means. Byte 26 should then be set to 0. |
| 17–24 | TS ₆₃ – TS ₀ | Time Stamp (eight bytes, SEG-D timestamp). Timestamp for which the rotation applies to, i.e. which sample the rotation applies to. Allows multiple rotation measurements during a record. May be recorded as 0, the values then applies to first sample in trace. |
| 25 | OT ₇ – OT ₀ | Orientation Type horizontal plane (one byte, unsigned binary). The rotation angle in bytes 9–12 is referenced to this coordinate system. The following values are defined 00 ₁₆ None/Unknown 01 ₁₆ Earth true north 02 ₁₆ Cable direction (e.g. marine/seabed streamer) 03 ₁₆ Sensor housing orientation 04 ₁₆ Survey orientation 05 ₁₆ Magnetic north 09 ₁₆ Other |
| 26 | ROV ₇ – ROV ₀ | Reference Orientation Valid (one byte, unsigned binary). Set to 1 if bytes 13–16 contains a valid value, otherwise recorded as 0. |
| 27 | RA ₇ – RA ₀ | Rotation Applied (one byte, unsigned binary). Set to 1 if rotation in bytes 1–12 has already been applied, otherwise recorded as 0. Allows recording of orientation values for QC purposes even though the rotation has already been done |
| 28 | RNA ₇ – RNA ₀ | Rotation to North Applied (one byte, unsigned binary). Set to 1 if values in traces has already been rotated to true north, otherwise recorded as 0. Rotation in bytes 1–16 has been applied to trace values. Allows recording of orientation values for QC purposes even though the rotation has already been done. If byte 28 is 1, byte 27 must also be set to 1. |
| 29–31 | X | These bytes are undefined by the format and may have any value. Note: In future versions these may be defined, so use with caution. |
| 32 | HT ₇ – HT ₀ | Header block type (one byte, unsigned binary). Set to 60 ₁₆ for Orientation Header. |

8.24 MEASUREMENT BLOCK (optional)

This block is used to standardize storage of different types of common measurements.

The Measurement Block may be followed by a Position Block describing where the measurement was taken.

NOTE: This block should not be used until final agreement with Energistics is reached regarding the unit of measurement system, and the proper resources are available. The web addresses listed below are not yet official, and may change before the agreement with Energistics is finalized.

| INDEX BYTE | ABBREVIATION | DESCRIPTION |
|---------------|--------------------------------------|----------------------------------------------------------------------------------------------------------------------------------------------------------------------------------------------------------------------------------------------------------------------------------------------------------------------------------------------------------------|
| 1–8 | TS ₆₃ – TS ₀ | Time Stamp (eight bytes, SEG-D timestamp). Timestamp for the measurement. Timestamp for time related measurements like Uphole time should be set to time zero for record (same as timestamp in General Header #3) if they are measuring the offset from start of record. |
| 9–12 | VA ₃₁ – VA ₀ | Measurement value (four bytes, IEEE float). Value of the measurement. |
| 13–16 | MA ₃₁ – MA ₀ | Maximum Value (four bytes, IEEE float). Maximum possible/allowed value of measurement. Set to NAN (Not a number, 7fffffff ₁₆) if not defined. |
| 17–20 | MI ₃₁ – MI ₀ | Minimum Value (four bytes, IEEE float). Mainimum possible/allowed value of measurement. Set to NAN (Not a number, 7fffffff ₁₆) if not defined. |
| 21–22 | QT ₁₅ – QT ₀ | Quantity Type (two bytes, unsigned binary). Code representing the underlying kind of measurement represented by GM1 (e.g. length, time, pressure, etc.). Please refer to the Energistics Quantity Type table located at http://www.seg.org/techstandards/measurements for the definition of codes. |
| 23-24 | UOM ₁₅ - UOM ₀ | Unit of Measure (two bytes, unsigned binary). Code of Unit of Measure for the measurement VA. Please refer to the Energistics Unit of Measure table located at http://www.seg.org/techstandards/measurements for the definition of codes. |
| 25-26 | GM ₁₅ – GM ₀ | Geophysical Meaning (two bytes, unsigned binary). Code representing Geophysical meaning of the measurement VA. Please refer to the Measurement Definition table located at http://www.seg.org/techstandards/measurements for the definition of codes. |
| 27-31 | X | Undefined. |
| 32 | HT ₇ – HT ₀ | Header block type (one byte, unsigned binary). Set to 61 ₁₆ for Measurement Block. |

8.25 ELECTROMAGNETIC SRC/RECV DESC BLOCK (optional)

| INDEX BYTE | ABBREVIATION | DESCRIPTION |
|------------|------------------------------------|--------------------------------------------------------------------------------------------------------------------------------------------------------------------------------------------------------------------------------------------------------------------------------------------------------------------------------|
| 1-3 | LX ₂₃ – LX ₀ | Equipment Dimension X direction (three bytes, unsigned binary). Length of measurement equipment (e.g. antenna) in X (inline) direction in number of centimeters (1/100 meters). Maximum length is 16777215 centimeters, or approximately 16777 meters. |
| 4-6 | LY ₂₃ – LY ₀ | Equipment Dimension Y direction (three bytes, unsigned binary). Length of measurement equipment (e.g. antenna) in Y (crossline) direction in number of centimeters (1/100 meters). Maximum length is 16777215 centimeters, or approximately 16777 meters. |
| 7-9 | LZ ₂₃ – LZ ₀ | Equipment Dimension Z direction (three bytes, unsigned binary). Length of measurement equipment (e.g. antenna) in Z (height) direction in number of centimeters (1/100 meters). Maximum length is 16777215 centimeters, or approximately 16777 meters. |
| 10 | PT ₇ – PT ₀ | Positive terminal (one byte, unsigned binary). Determines the positive terminal for the antenna. Bits 0-2 determines if the positive end (i.e. antenna end with largest positive value) in X, Y and Z direction respectively is the positive terminal. Set bit to 1 if positive end is positive terminal, 0 if it is negative. |

Example: The antenna is 15 meters in inline direction, positive terminal is at the positive end of the antenna. LX is set to 0005DC₁₆, LY to 000000₁₆, LZ to 000000₁₆, PT to 01₁₆.

Example 2: Antenna is 25 meters diagonally in X-Y direction, positive terminal is negative X, positive Y value. Length in X and Y direction is $\sqrt{25^2/2}=17.68$ meters. LX is set to 0006E8₁₆, LY to 0006E8₁₆, LZ to 000000₁₆, PT to 02₁₆.

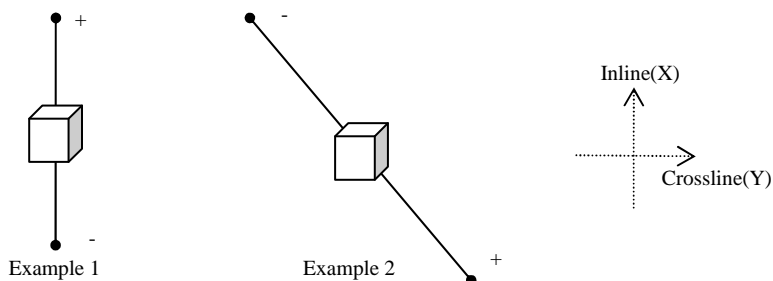

| | | |
|-------|------------------------------------|--------------------------------------------------------------------------------------------------------------------------------------------------------------------------------------------------------------------------------------------------------------------------------------------|
| 11-13 | OX ₂₃ – OX ₀ | Equipment Offset X direction (three bytes, two's complement, signed binary). Measurement equipment (e.g. antenna) offset from center of equipment in X (inline) direction in number of centimeters (1/100 meters). Maximum offset is +/-8388607 centimeters, or approximately 8388 meters. |
|-------|------------------------------------|--------------------------------------------------------------------------------------------------------------------------------------------------------------------------------------------------------------------------------------------------------------------------------------------|

| | | |
|-------|------------------------------------|-----------------------------------------------------------------------------------------------------------------------------------------------------------------------------------------------------------------------------------------------------------------------------------------------|
| 14–16 | OY ₂₃ – OY ₀ | Equipment Offset Y direction (three bytes, two's complement, signed binary). Measurement equipment (e.g. antenna) offset from center of equipment in Y (crossline) direction in number of centimeters (1/100 meters). Maximum offset is +/-8388607 centimeters, or approximately 8388 meters. |
| 17–19 | OZ ₂₃ – OZ ₀ | Equipment Offset Z direction (three bytes, two's complement, signed binary). Measurement equipment (e.g. antenna) offset from center of equipment in Z (height) direction in number of centimeters (1/100 meters). Maximum offset is +/-8388607 centimeters, or approximately 8388 meters. |
| 20–31 | X | Undefined. |
| 32 | HT ₇ – HT ₀ | Header block type (one byte, unsigned binary). Set to 45 ₁₆ for Electromagnetic Src/Recv Desc block |

8.26 GENERAL TRAILER (Optional)

The general trailer consists of data block units of varying size. Each data block starts with a description block (32 bytes) followed by data (either binary or ASCII) in a multiple of 32 bytes.

The content of the trailer data blocks is completely recording system defined. However, some types have been predefined to simplify exchange of data. The predefined types (e.g. edits) can be found in table listed for Byte 1 in the General Trailer Description block below.

Binary data padded with zeros (00₁₆), ASCII data padded with spaces (20₁₆), until 32 byte limit.

Layout of the general trailer will be like this:

[GT desc block (32 byte)][Block 1 (x*32 byte)][GTDB][Block 2][GTDB][Block 3]...

This is done to simplify appending data.

8.26.1 GENERAL TRAILER DESCRIPTION BLOCK (optional)

| Field | Description | Bytes | Start – end byte |
|-------|---------------------------------------|-------|------------------|
| 1 | Trailer Block type/id | 1 | 1 |
| 2 | ASCII/Binary data | 1 | 2 |
| | Undefined (zero-filled) | 2 | 3–4 |
| 3 | Size (unsigned binary) | 4 | 5–8 |
| 4 | Description (ASCII) if type other | 16 | 9–24 |
| | Undefined (zero-filled) | 6 | 25–31 |
| 5 | Header block type (70 ₁₆) | 1 | 32 |

| INDEX BYTE | ABBREVIATION | DESCRIPTION |
|---------------|------------------------------------|--------------------------------------------------------------------------------------------------------------------------------------------------------------------------------------------------------------------------------------------------------------------------------------------------------------------------------------------------------------------------------------------------------------------------------------------------------------------------------------------------------------------------------------------------------------------------------------------------------------------------------------------------------|
| 1 | BT ₇ – BT ₀ | Block type, (one byte, unsigned binary). This describes the type of data in this block. 01 ₁₆ Edits 10 ₁₆ Text comments 11 ₁₆ Observer log 20 ₁₆ P1 processed navigation data 21 ₁₆ P2 Raw marine positioning data 22 ₁₆ P3 Land survey field data 23 ₁₆ P5 Pipeline positioning data 24 ₁₆ P6 3D seismic binning grids 25 ₁₆ P7 Well deviation data 26 ₁₆ SPS Shell Processing Support data 27 ₁₆ SEG-Y Extended Textual Stanza A0 ₁₆ – FF ₁₆ Other (user defined) |
| 2 | AB ₇ – AB ₀ | ASCII or binary (one byte, unsigned binary). States if data in this block is binary or ASCII text. 01 ₁₆ Binary 02 ₁₆ ASCII |
| 3–4 | X | Undefined, set to 0. |
| 5–8 | SI ₃₁ – SI ₀ | Block size (four bytes, unsigned binary). Number of 32 byte blocks in this data block. Block size in bytes = 32 * SI |
| 9–24 | DE | Description (16 bytes, ASCII). A description of the contents of this data block. Must be filled out if block type is Other/User defined (A0 ₁₆ – FF ₁₆). Unused characters are filled with ASCII space (20 ₁₆) characters. |
| 25–31 | X | Undefined, set to 0. |
| 32 | HT ₇ – HT ₀ | Header block type (one byte, unsigned binary). Set to 70 ₁₆ for General Trailer Description Block. |

Note: All types of trailer records are optional.

Appendix A: Manufacturers of Seismic Field Recorders

| <u>Code No.</u> | <u>Manufacturer Name and Address</u> |
|-----------------|---------------------------------------------------------------------------------------------------------------------------------------------------------|
| 01 | Alpine Geophysical Associates, Inc. (Obsolete) 65 Oak St. Norwood, New Jersey |
| 02 | Applied Magnetics Corporation (See 09) 75 Robin Hill Rd. Goleta, California 93017 |
| 03 | Western Geophysical Exploration Products (formerly Litton Resources Systems) 3600 Briarpark Drive, Houston, Texas 77042 |
| 04 | SIE, Inc. (Obsolete) 5110 Ashbrook Houston, Texas 77036 |
| 05 | Dyna-Tronics Mfg. Corporation (Obsolete) 5820 Star Ln., Box 22202 Houston, Texas 77027 |
| 06 | Electronic Instrumentation, Inc. (Obsolete) 601 Dooley Rd., Box 34046 Dallas, Texas 75234 |
| 07 | Halliburton Geophysical Services, Inc.,(formerly, Electro-Technical Labs, Div. of Geosource, Inc.) 6909 Southwest Freeway Houston, Texas 77074 |
| 08 | Fortune Electronics, Inc. (Obsolete) 5606 Parkersburg Dr. Houston, Texas 77036 |
| 09 | Geo Space Corporation 7334 Gessner Houston, Texas 77040 |
| 10 | Leach Corporation (Obsolete) 405 Huntington Dr. San Marino, California |

- 11 Metrix Instrument Co. (Obsolete)
8200 Westglen
Box 36501
Houston, Texas 77063
- 12 Redcor Corporation (Obsolete)
7800 Deering Ave., Box 1031
Canoga Park, California 91304
- 13 Sercel (Societe d'Etudes, Recherches Et Constructions Electroniques)
25 X, 44040 Nantes Cedex,
France
- 14 Scientific Data Systems (SDS), (Obsolete)
1649 Seventeenth St.
Santa Monica, California 90404
- 15 Texas Instruments, Inc.
P.O. Box 1444
Houston, Texas 77001
- 17 GUS Manufacturing, Inc.
P.O. Box 10013
El Paso, Texas 79991
- 18 Input/Output, Inc.
12300 Parc Crest Dr.
Stafford, Texas 77477
- 19 Geco-Prakla
Transition Zone Product Development
(formerly Terra Marine Engineering)
10420 Miller Road
Dallas, Texas 75238
- 20 Fairfield Industries, Incorporated
10627 Kinghurst
Houston, Texas 77099
- 22 Geco-Prakla
Buckingham Gate, Gatwick Airport
West Sussex, RH6 ONZ, UK
- 31 Japex Geoscience Institute 1991
Akasaka Twin Towers Bldg. 2;
2-17-22, Akasaka
Minato-ku; Tokyo 107, Japan
- 32 Halliburton Geophysical Services, Inc. 1991
6909 Southwest Freeway
Houston, Texas 77074

| | | |
|----|----------------------------------------------------------------------------------------------------------------------------|------|
| 33 | Compuseis, Inc. 8920 Business Park Dr, Ste 275, Austin, Texas 78759 | 1993 |
| 34 | Syntron, Inc. 17200 Park Row Houston, Texas 77084 | 1993 |
| 35 | Syntron Europe Ltd. Birchwood Way Cotes Park Industrial Estates Somercotes, Alfreton, Dergysire DE55 4QQ, U.K. | 1993 |
| 36 | Opseis 7700 E. 38th St. Tulsa, OK 74145 | 1994 |
| 39 | Grant Geophysical 16850 Park Row Houston, Tx 77084 | 1995 |
| 40 | Geo-X Suite 900, 425 1st St SW Calgary, Alberta, Canada T2P3L8 | 1996 |
| 41 | PGS Inc. 16010, Barkers Point Lane, Houston Texas 77079 | 2001 |
| 42 | SeaMap UK Ltd. Unit 31 The Maltings Charlton Estate Shepton Mallet BA4 5QE UK | 2003 |
| 43 | Hydroscience Hydroscience Technologies, Inc. 5101 Airport Road Mineral Wells, Texas 77478 USA | 2004 |
| 44 | JSC “SPECIAL DESIGN BUREAU FOR SEISMIC INSTRUMENTATION” 129, Krainyaya Str., 410019 Saratov, RUSSIA | 2006 |
| 45 | Fugro Hoffsveien 1C N-0213 Oslo | 2006 |

NORWAY

| | | |
|----|--------------------------------------------------------------------------------|------|
| 46 | ProFocus Systems AS Spelhaugen 20 5147 Fyllingsdalen NORWAY | 2006 |
| 47 | Optoplan AS Haakon VII's gate 17 7041 Trondheim NORWAY | 2008 |
| 48 | Wireless Seismic Inc 12996 Somerset Drive Grass Valley, CA 95945 USA | 2008 |
| 49 | AutoSeis 2101 Midway Road Suite 310 Carrolton, TX 75006 USA | 2010 |
| 50 | INOVA Geophysical, Inc. 12200 Parc Crest Drive Stafford, TX 77477 USA | 2011 |

Appendix B: Glossary

Attribute – A named item of information or data pertaining to an object.

Base scan interval – The time between timing words. A base scan interval usually contains one scan but under some conditions may contain multiple subscans.

Beginning of tape mark (BOT) – An indelible mark (e.g., reflector) near the beginning of the tape that indicates the start of the region in which recorded data is permitted.

Block – The data between gaps on tape. On modern tape devices block may be a logical marks only, not an actual gap on the tape. A block usually refers to the smallest amount of data possible to read from the device.

Channel set – One or more channels sampled at the same sampling interval and containing the same filter, fixed gain, and other fixed parameter information.

Channel set descriptor – A unit of the scan type header describing the parameters of a channel set.

Data recording method – The arrangement of bits to represent samples on tape.

End of data flag (EOD) – A special record or condition on the tape used to indicate the end of data on the tape.

End of file mark (EOF) – A special record or condition on the tape that indicates the end of a tape file. Also called File Mark.

End of tape warning (ETW) – An indelible mark (e.g., reflector), located a required minimum distance from the physical end of the tape that serves as a warning.

Field record – The data between two filemarks on media that supports this (e.g. tape). The field record may consist of multiple SEG-D records. For media without filemarks the field record equals a SEG-D record. (See also **File**)

File – Literally, it is all of the blocks between file marks. The term **Field File** is sometimes used instead of File. It is all data recorded from a one or more energy impulses or sweeps, stored in one or more SEG-D records. It may also be the sum of a number of energy impulses or sweeps, or data recorded without any source actions. (See also **Field record**.)

Filemark – A special record or state of a media index that indicates the end of a physical file.

Format Data – recording method combined with a multiplexed/demultiplexed indicator (see general header Bytes 3 and 4).

General header – The first header in the header block. It contains information common to the entire record.

Index byte – The byte number of some particular parameter within the general or scan type header.

Organization code – A number assigned by the Petroleum Open Standards Consortium (POSC) to an organization that identifies the organization and represents schemas and dictionaries defined and administered by the organization.

Packed BCD – Binary coded decimal digits represented by four data bits.

Partition – An independent recording area resulting from physical formatting of the media that can be mounted as though it were a single volume.

Physical blocks (on tape) – A collection of contiguous bytes recorded as a unit on a longitudinal tape or a track set on helical scan tape. Physical blocks on longitudinal tape are separated by interblock gaps.

Record – A SEG-D record is a collection of data traces and meta-data describing those traces. It is also allowed to create a record with the meta-data only. The record consists of a header (mandatory), data traces and a record trailer. Sometimes the terms **Shot record** or **Seismic record** is used to describe a SEG-D record.

Sample skew – The fraction of the base scan interval between the timing word and the actual time the sample was taken in a base scan interval (not related to position on tape).

Sampling interval – The interval between readings such as the time between successive samples of a digital seismic trace.

Scan – One complete sequence of events, such as sampling all channels. Data recorded during a base scan interval.

Scan interval – The interval between readings of all samples contained in a scan type.

Scan type – One complete set of channel sets which make up a scan. A seismic record contains multiple scans, and may or may not contain more than one scan type.

Scan type header – A header containing one or more channel set descriptors and the skew information.

Schema – A formalized description of the encoding of information defined by a logical model, typically in terms of a data model.

Storage set – An ordered set of storage units, the position in the set is specified in the storage unit label.

Storage unit – A logical volume of data containing one or more logical files.

Subscan – A set of samples containing one sample for each channel in a channel set.

Tape file – Is the data contained between two File Marks or between an File Mark at its beginning and an EOD at its end. A typical implementation of EOD is an empty tape file, i.e., two consecutive File Marks. Some systems implement EOD as two or more (possibly many) File Marks.

Tape record – A sequence of data bytes treated as a unit by the tape I/O subsystem. The application provides the number of bytes in the tape record when writing and is returned the number of bytes in the tape record when reading. A tape record has an identifiable beginning on the tape, which need not be on the boundary of a physical block, and which is locatable by the tape I/O subsystem.

Time break window – Time interval in which time break is expected. If time break does not occur by the end of the window, internal time break is generated.

Trace - A record of one seismic channel within a scan type. A collection of a sequential set of points from one seismic channel.

Trace block - A block containing the data of one trace or a part of a trace with constant parameters.

Appendix C: API Producer Organization Code

C.1 Scope

Table 1 below contains a list of *organization codes* assigned by the *Petrotechnical Open Standards Consortium (POSC)* for use in API Recommended Practice 66. *Several of the organization codes in this appendix are historical in nature and reflect the well log origins of API Recommended Practice 66.*

This specification was originally prepared by the Subcommittee on Standard Format for Digital Well data. In June 1996 it was designated a recommended practice by the American Petroleum Institute [API] Exploration & Production Department's Executive Committee on Drilling and Production Practices. In June 1998 stewardship of the document was transferred from API to Petroleum Open Standards Consortium [POSC]. This organization was relaunched as Energistics in December 2006.

C.2 Assignment of Organization Codes

Organization codes are assigned by Energistics, which maintains the current list of codes. To request a new organization code, contact:

Energistics
24 E. Greenway Plaza
Suite 1315
Houston, TX 77046-2414 USA
+1 713 784-1880 telephone
+1 713 784-9219 fax
info@energistics.org
http://www.energistics.org/

The following is copied from

<http://w3.energistics.org/RP66/V2/Toc/main.html>

This document, *POSC RP66 V2*, is a specification of Petrotechnical Open Standards Consortium.

This specification is based on and is equivalent in content to the document *Recommended Practices for Exploration and Production Data Digital Interchange: API RECOMMENDED PRACTICE 66, V2: Second Edition, June 1996* published by the American Petroleum Institute (API). The acronym ***RP66V2*** is retained for historical reasons; POSC does not designate specifications as "Recommended Practices".

The following table is copied from

<http://www.energistics.org/rp66-organization-codes>

Last Updated 14 Jan 2011

Table 1— Organization Codes

| Name (Code) | Description (Organization Name) |
|----------------|---------------------------------------------------------------------------|
| 0 | Subcommittee On Recommended Format For Digital Well Data, Basic Schema |
| 1 | Operator |
| 2 | Driller |
| 3 | Mud Logger |
| 9 | Amerada Hess |
| 10 | Analysts, The |
| 15 | Baker Hughes Inteq |
| 20 | Baroid |
| 30 | Birdwell |
| 40 | Reeves (1 Jan 99; formerly BPB) |
| 50 | Brett Exploration |
| 58 | Canrig (added 2009-09-09) |
| 60 | Cardinal |
| 65 | Center Line Data |
| 66 | Subcommittee On Recommended Format For Digital Well Data, DLIS Schema |
| 70 | Century Geophysical |
| 77 | CGG Logging, Massey France |
| 80 | Charlene Well Surveying |
| 90 | Compagnie de Services Numerique |
| 95 | Comprobe |
| 100 | Computer Data Processors |
| 110 | Computrex |
| 115 | COPGO Wood Group |
| 120 | Core Laboratories |
| 125 | CRC Wireline, Inc. |
| 126 | Crocker Data Processing Pty Ltd |
| 127 | Tucker Wireline Services (formerly Davis Great Guns Logging, Wichita, KS) |
| 128 | Datalog Technology (added 2009-09-09) |
| 130 | Digigraph |
| 137 | Tucker Technologies (formerly Digital Logging Inc.), Tulsa, OK. |
| 140 | Digitech |
| 145 | Deines Perforating |
| 148 | Drillog Petro-Dynamics Limited |
| 150 | Baker Atlas (formerly Dresser Atlas) |
| 160 | Earthworm Drilling |
| 170 | Electronic Logging Company |
| 180 | Elgen |
| 190 | El Toro |

| | |
|-----|-------------------------------------------------------------------|
| 200 | Empire |
| 205 | Encom Technology, Ltd. |
| 206 | Ensign Geophysics, Ltd. |
| 208 | Epoch (merged with Canrig, Nov 2008; added 2009-09-09) |
| 210 | Frontier |
| 215 | Geolog |
| 217 | Geoshare |
| 218 | GEO·X Systems Ltd. |
| 220 | G O International |
| 230 | Gravilog |
| 240 | Great Guns Servicing |
| 250 | Great Lakes Petroleum Services |
| 260 | GTS |
| 268 | Guardian Data Seismic Pty. Ltd. |
| 270 | Guns |
| 280 | Halliburton Logging |
| 285 | Horizon Production Logging |
| 290 | Husky |
| 293 | INOVA Geophysical (added 2011-01-03) |
| 295 | Input/Output, Inc. |
| 300 | Jetwell |
| 305 | Landmark Graphics |
| 310 | Lane Wells |
| 315 | Logicom Computer Services (UK) Ltd |
| 320 | Magnolia |
| 330 | McCullough Tool |
| 332 | Mitchell Energy Corporation |
| 335 | Paradigm Geophysical (formerly Mincom Pty Ltd) |
| 337 | DPTS Limited (formerly MR-DPTS Limited, changed as of 2008-08-12) |
| 338 | NRI On-Line Inc |
| 339 | Oilware, Inc. |
| 340 | Pan Geo Atlas |
| 342 | Pathfinder Energy Services |
| 345 | Perfco |
| 350 | Perfojet Services |
| 360 | Perforating Guns of Canada |
| 361 | Petcom, Inc. |
| 362 | Petroleum Exploration Computer Consultants, Ltd. |
| 363 | Petrologic Limited |
| 366 | Phillips Petroleum Company |
| 367 | Phoenixdata Services Pty Ltd. |

| | |
|------|----------------------------------------------------------------|
| 368 | Petroleum Geo-Services (PGS) |
| 370 | Petroleum Information |
| 380 | Petrophysics |
| 390 | Pioneer |
| 392 | The Practical Well Log Standards Group |
| 395 | IHS Energy Log Services (formerly Q. C. Data Collectors) |
| 400 | Ram Guns |
| 410 | Riley's Datashare |
| 418 | RODE |
| 420 | Roke |
| 430 | Sand Surveys |
| 440 | Schlumberger |
| 450 | Scientific Software |
| 460 | Seismograph Service |
| 462 | SEGDEF |
| 463 | SEG Technical Standards High Density Media Format Subcommittee |
| 464 | Shell Services Company |
| 465 | Stratigraphic Systems, Inc. |
| 467 | Sperry-Sun Drilling Services |
| 468 | SEPTCO |
| 469 | Sercel, Inc. |
| 470 | Triangle |
| 471 | Thrubit Logging(added 2009-09-09) |
| 475 | Troika International |
| 480 | Welex |
| 490 | Well Reconnaissance |
| 495 | Wellsite Information Transfer Specification (WITS) |
| 500 | Well Surveys |
| 510 | Western |
| 520 | Westronics |
| 525 | Winters Wireline |
| 530 | Wireline Electronics |
| 540 | Worth Well |
| 560 | Z & S Consultants Limited |
| 999 | <i>Reserved for local schemas</i> |
| 1000 | Energistics (formerly POSC, changed as of 2006-11-06) |

Appendix D: Coordinate Reference System identification

The following stanzas are extended versions of the SEG-Y Rev 1 Location Data stanza. The structure for Extended Textual stanzas is described in section 6.1 of SEG-Y Revision 1 (http://www.seg.org/SEGportalWEBproject/prod/SEG-Publications/Pub-Technical-Standards/Documents/seg_y_rev1.pdf) and summarized in the following:

The ground rules for stanzas that use this schema are as follows:

- Each line consists of a keyword/value pair in the form “keyword = value”.
- The keywords and values can contain any printable character except double right or double left parentheses or the equal sign. However, the use of punctuation characters in keywords is not recommended.
- The case of a keyword is not significant.
- For readability, spaces within a keyword are allowed but ignored. Thus the keyword “Line Name” refers to the same keyword as “LINENAME”.
- The value associated with a keyword begins with the first non-blank character following the equal sign and extends to the last non-blank character on the line.
- The value field for a keyword may consist of multiple subfields, separated by commas (“,”, EBCDIC 6B₁₆ or ASCII 2C₁₆).
- Blank lines are ignored.
- If the first non-blank character in a line is the hash sign (“#”, EBCDIC 7B₁₆ or ASCII 23₁₆), the line is treated as a comment and ignored.
- If the last non-blank character on a line is an ampersand (“&”, EBCDIC 50₁₆ or ASCII 16₁₆), the next line is considered to be a continuation of the current line (i.e. the next line is concatenated with the current line, with the ampersand removed).

Each line in an Extended Textual File Header ends in carriage return and linefeed (EBCDIC 0D25₁₆ or ASCII 0D0A₁₆)

D.1 Location Data

Location stanzas provide the definitions for the system to which coordinates given in this SEG-D format file are referenced. Without this information the coordinates are ambiguous. The stanzas for this coordinate reference system definition are described in D.1.1. Examples are given in D.1.2.

If during acquisition a coordinate transformation has been applied to derive the coordinates defined through the location stanza (for example when the location data has been transformed from the GPS system's WGS 84 coordinates to coordinates referenced to a local Coordinate Reference System), details of the transformation applied should additionally be given through a Coordinate Transformation stanza. The stanzas for this transformation are defined in D.1.3. Examples are given in D.1.4.

Some keywords in both the Location Data stanza (D.1.1 table 1.2) and the Location Data Coordinate Transformation stanza (D.1.3 table 1.4) require entry of a parameter from the EPSG Geodetic Parameter Dataset. In some cases, such as unit of measure, the user has the ability to specify the Unit Name, Unit Code and/or Conversion Factor (to canonical Unit of Measure). The EPSG dataset is available at www.epsg.org or online at www.epsg-registry.org.

Degree Representation

A **sexagesimal degree** is defined as “a plane angle represented by a sequence of values in degrees, minutes and seconds. In the case of latitude or longitude, may also include a character indicating hemisphere.” For example: 50.0795725 degrees is represented as 50°04'46.461"N sexagesimal degrees. To store this in numeric form requires three or four fields. The EPSG dataset includes a pseudo-unit named sexagesimal DMS which allows the storage of a sexagesimal degree in one numeric field. The format is:

signed degrees - period - minutes (two digits) - integer seconds (two digits) - fraction of seconds (any precision). Must include leading zero in minutes and seconds and exclude decimal point for seconds.

For example 50°04'46.461"S may be represented as –50.0446461 in sexagesimal DMS.

This “unit” is used for documenting (mainly map projection) parameter values where the values must be exactly preserved and rounding through conversion to decimal degrees cannot be tolerated.

Note that the value given in decimal degrees (e.g. 50.0795725) will differ from its equivalent value given in sexagesimal DMS (50.0446461) only in the decimal part and that the two representations may be easily confused. Any value given in sexagesimal DMS must be clearly labeled as such.

Sexagesimal DMS must be used *only* for geodetic parameter values in the extended textual location data stanzas. For latitude and longitude coordinates given in General Header records, signed decimal degrees must be used.

D.1.1 Location Data stanza

The Location Data stanza identifies the Coordinate Reference System (CRS) to which data recording locations, such as source and group, and derived locations, for example CDP, are referenced. The CRS serves as a reference for both horizontal positioning, such as easting and northing, and vertical positioning, such as elevations and depths. Without this identification these coordinates are ambiguous. This information may be given implicitly² through reference to the EPSG Geodetic Parameter Dataset (Table 1.1) or explicitly³ (Table 1.2).

Whenever the Coordinate Reference System used is included in the EPSG dataset both the implicit and explicit definition Textual Location Data stanzas may be provided to ease decoding in environments that lack direct internet access to the EPSG dataset. If a user extended version of the EPSG dataset is utilized with a code outside of the EPSG reserved range, then explicit definition is required.

If more than one CRS is used for a given seismic survey, then multiple Location Data Stanzas with unique non-ambiguous IDs must also be populated. Multiple Location Data Stanza IDs may also be used for continuation of stanzas over 3200 bytes to ensure proper continuity and repetition for oversized stanzas.

² Implicit definition of the Coordinate Reference System (CRS) to which a set of coordinates is referenced requires the user to specify only the appropriate CRS code and the dataset version number of the EPSG dataset from which that CRS definition was obtained. See Table 1.1 for required data for an implicit CRS definition.

³ Explicit definition of the Coordinate Reference System (CRS) to which a set of coordinates is referenced requires specifying all of the key attributes and parameters necessary to define the CRS. See Table 1.2 for required data in an explicit CRS definition.

Table 1.1 Stanza for implicit identification of Location Data

| Stanza Header and Keyword | Format | Resolution / Limits | Comment |
|-----------------------------------------------|---------------|--------------------------------------------------------------------------------------------------------------------------|---------------------------------------------------------------------------------------------------------------------------------------------|
| ((SEG: Location Data EPSG Reference ver 3.0)) | Text | | Stanza name |
| Location Data Stanza ID = | Long Integer | ID is user defined;. range 1 to 65535. | Reference from coordinate tuple given in Position block.. |
| CRS code = | Long integer | EPSG code range is limited to 1–32767, but other database users may add their own code extensions outside of this range. | The code of the Coordinate Reference System as given in the EPSG Geodetic Parameter Dataset, www.epsg.org |
| CRS name = | Text | 80 character limit | The name of the Coordinate Reference System as given in the EPSG Geodetic Parameter Dataset, www.epsg.org |
| Dataset version ⁴ = | Text | 80 character limit | The release number for the EPSG Geodetic Parameter Dataset. |

⁴ For all EPSG dataset versions from EPSG v6.0 onward the code itself (without version number) would be sufficient, as from v6.0 onward code number will always remain unique. However, adding the version number is a good bit of insurance.

Table 1.2 Stanza for explicit definition of Location Data

| Stanza Header and Keyword | Format | Resolution / Limits | Comment |
|---------------------------------------------------------------------------------------------------------------------------------------------------------------------------|-------------------------------------------------------------------------------------------------------|-----------------------------------------------------------------------------------------------------------------------------------------------------------------------------------------------------------------------|-----------------------------------------------------------------------------------------------------------------------------------------------------------------|
| ((SEG: Location Data ver 3.0)) | Text | | Stanza name |
| <i>The following keywords apply to all Coordinate Reference Systems (CRS):</i> | | | |
| Location Data Stanza ID = | Long Integer | ID is user defined; range 1 to 65535. | Reference from coordinate tuple given in Position block. |
| CRS type = | Text from list projected geographic2D geographic3D vertical geocentric compound | 24 character limit, but must be from specified “look up” list. | See EPSG dataset www.epsg.org and accompanying guidance notes for information on CRS type. |
| CRS name = | Text | 80 character limit | The name of the Coordinate Reference System. |
| <i>The following keywords are additionally required if CRS type = compound:</i> | | | |
| Horizontal CRS name = | Text | 80 character limit | The name of the CRS forming the horizontal component of the compound CRS. The CRS type may be projected or geographic2D. |
| Vertical CRS name = | Text | 80 character limit | The name of the CRS forming the vertical component of the compound CRS. The CRS type will be vertical. |
| The definitions of these two component CRSs should then be provided through the relevant keywords below. | | | |
| <i>The following keywords are additionally required if CRS type = projected or geographic2D, or compound including one of these types, or geographic3D or geocentric:</i> | | | |
| Geodetic Datum name = | Text | 80 character limit | The name of the Geodetic Datum. |
| Prime Meridian name = | Text | 80 character limit | Mandatory if not “Greenwich”. Note: most, but not all, Coordinate Reference Systems use Greenwich as the prime meridian (PM). |
| PM Greenwich longitude = | Real Number | IEEE double precision normally represented/provided to seven decimal places of a degree. Range $-180 \leq \lambda_G \leq +180$ degrees or equivalent in other units. See EPSG dataset for examples of values / ranges | The longitude of the CRS’s prime meridian relative to the Greenwich meridian, positive if east of Greenwich. Not required if Prime Meridian name = “Greenwich”. |

| Stanza Header and Keyword | Format | Resolution / Limits | Comment |
|---------------------------------------------------------------------------------------------|---------------|--------------------------------------------------------------------------------------------------------------------------------------------|---------------------------------------------------------------------------------------------------------------------------------------------------------------------------------------------------------------------------------------------------------------------------------------|
| PM Greenwich longitude unit code = | Long integer | EPSG code range is limited to 1–32767, but other database users may add their own code extensions outside of this range. | Not required if Prime Meridian name = “Greenwich”. If Prime Meridian name is not "Greenwich" then at least one of EPSG unit code, unit name or unit conversion ratio to radian is required. Example conversion ratio: if unit = degree, conversion ratio $\approx 0.01745329\dots$ |
| PM Greenwich longitude unit name = | Text | 80 character limit, but must be from EPSG Unit of Measure table Name field. | |
| PM Greenwich longitude unit conversion = | Real Number | IEEE double precision. | |
| Ellipsoid name = | Text | 80 character limit | |
| Ellipsoid semi-major axis = | Real Number | IEEE double precision, normally given to 10 significant figures. Range $6350 < a < 6400$ km or equivalent in other units. | See EPSG dataset for examples of values / ranges. |
| Semi-major axis unit code = | Long integer | EPSG code range is limited to 1–32767, but other database users may add their own code extensions outside of this range. | At least one of EPSG unit code, unit name or unit conversion ratio to meter is required. Example conversion ratio: if unit = US Survey foot, conversion ratio $\approx 0.3048006096\dots$ |
| Semi-major axis unit name = | Text | 80 character limit, but must be from EPSG Unit of Measure table Name field. | |
| Semi-major axis unit conversion = | Real Number | IEEE double precision. | |
| Ellipsoid inverse flattening = | Real Number | IEEE double precision normally given to 10 significant figures. Range $250 < 1/f < 350$. See EPSG dataset for examples of values / ranges | If a sphere, $1/f$ is infinite. In this case enter value of 0. |
| <i>The following keyword is additionally required when CRS type = vertical or compound:</i> | | | |
| Vertical Datum name = | Text | 80 character limit | The name of the Vertical Datum. Not required if ellipsoidal heights are given - these are part of a geographic3D CRS. (Most heights and depths are gravity-related, not ellipsoidal). |

| Stanza Header and Keyword | Format | Resolution / Limits | Comment |
|-----------------------------------------------------------------------------------------------------------------------------------------------------------------------------------------------------------------------------------|--------------|--------------------------------------------------------------------------------------------------------------------------|-----------------------------------------------------------------------------------------------------------------------------------------------------------------------------------------------------------------------------------------------------------------------------------------------------------------------------------------------------------------------|
| <i>The following keywords are additionally required when CRS type = projected or when a Bin Grid Definition stanza or a Data Geographic Extent stanza or a Coverage Perimeter stanza is included in the extended file header:</i> | | | |
| Projection name = | Text | 80 character limit | |
| Projection method name = | Text | 50 character limit | For example: "Transverse Mercator", "Lambert Conic Conformal (1SP)", "Lambert Conic Conformal (2SP)". |
| Projection parameter 1 name = | Text | 80 character limit | The number and name of projection defining parameters is dependent upon the map projection method. See the EPSG Geodetic Parameter Dataset coordinate operation method table for parameters required by each projection method. |
| Projection parameter 1 value = | Real Number | IEEE double precision. See EPSG dataset for examples of values / ranges | |
| Projection parameter 1 unit code = | Long integer | EPSG code range is limited to 1–32767, but other database users may add their own code extensions outside of this range. | At least one of EPSG unit code, unit name or unit conversion ratio to standard unit (radian for angle, meter for length, unity for scale) is required. Example conversion ratios: if unit = degree, conversion ratio $\approx 0.01745329\dots$; if unit = US Survey foot, conversion ratio $\approx 0.3048006096\dots$; if unit = unity, conversion ratio = 1.0. |
| Projection parameter 1 unit name = | Text | 80 character limit, but must be from EPSG Unit of Measure table Name field. | |
| Projection parameter 1 unit conversion = | Real Number | IEEE double precision. | |
| : : | | | |
| Projection parameter n name = | Text | 80 character limit | |
| Projection parameter n value = | Real Number | IEEE double precision. See EPSG dataset for examples | |

| Stanza Header and Keyword | Format | Resolution / Limits | Comment |
|-------------------------------------------------------------------------------------------------------------------------------------------------------------------------------------------|---------------|--------------------------------------------------------------------------------------------------------------------------|-----------------------------------------------------------------------------------------------------------------------------------------------------------------------------------------------------------------------------------------------------------------------------------------------------------------------------------------------------|
| Projection parameter n unit code = | Long integer | EPSG code range is limited to 1–32767, but other database users may add their own code extensions outside of this range. | At least one of EPSG unit code, unit name or unit conversion ratio to standard unit (radian for angle, meter for length, unity for scale) is required. Example conversion ratios: if unit = grad, conversion ratio $\approx 0.01570796\dots$; if unit = International foot, conversion ratio = 0.3048; if unit = unity, conversion ratio = 1.0. |
| Projection parameter n unit name = | Text | 80 character limit, but must be from EPSG Unit of Measure table Name field. | |
| Projection parameter n unit conversion = | Real Number | IEEE double precision. | |
| <i>The following keywords are additionally required if CRS type = projected or geographic2D or geographic3D or geocentric or compound (they are not required if CRS type = vertical):</i> | | | |
| Coordinate System axis 1 name = | Text | 80 character limit | The name or abbreviation of the Coordinate System (CS) axis for the coordinate in Position block Coord 1. For example: easting, latitude, X, E, or geocentric X. |
| CS axis 1 orientation = | Text | 24 character limit | The positive direction for axis 1. For example: “east”, or “north”. |
| CS axis 1 unit code = | Long integer | EPSG code range is limited to 1–32767, but other database users may add their own code extensions outside of this range. | At least one of EPSG unit code, unit name or unit conversion ratio to standard unit (radian for angle, meter for length, unity for scale) is required. Example conversion ratios: if unit = grad, conversion ratio $\approx 0.01570796\dots$; if unit = International foot, conversion ratio = 0.3048; if unit = unity, conversion ratio = 1.0. |
| CS axis 1 unit name = | Text | 80 character limit, but must be from EPSG Unit of Measure table Name field. | |
| CS axis 1 unit conversion = | Real Number | IEEE double precision. | |
| Coordinate System axis 2 name = | Text | 80 character limit | The name or abbreviation of the axis for the coordinate in Position block Coord 2. For example: northing, Y, N, or longitude. |
| CS axis 2 orientation = | Text | 24 character limit | The positive direction for axis 2. For example: “north” or “east”. |
| CS axis 2 unit code = | Long integer | EPSG code range is limited to 1–32767, but other database users may add their own code extensions outside of this range. | At least one of EPSG unit code, unit name or unit conversion ratio to standard unit (radian for angle, meter for length, unity for scale) is required. Example conversion ratios: if unit = grad, conversion ratio $\approx 0.01570796\dots$; if unit = International foot, conversion |

| Stanza Header and Keyword | Format | Resolution / Limits | Comment |
|----------------------------------------------------------------------------------------------------------------------------------------------------------------------------------------------|---------------|--------------------------------------------------------------------------------------------------------------------------|-----------------------------------------------------------------------------------------------------------------------------------------------------------------------------------------------------------------------------------------------------------------------------------------------------------------------------------------------------|
| CS axis 2 unit name = | Text | 80 character limit, but must be from EPSG Unit of Measure table Name field. | ratio = 0.3048; if unit = unity, conversion ratio = 1.0. |
| CS axis 2 unit conversion = | Real Number | IEEE double precision. | |
| <i>The following keywords are additionally required when CRS type = geographic3D or geocentric or vertical or compound (they are not required if CRS type = projected or geographic 2D):</i> | | | |
| Coordinate System axis 3 name = | Text | 80 character limit | The name or abbreviation of the axis for the elevations and depths in Position block Coord3. For example: gravity-related height, ellipsoidal height. |
| CS axis 3 orientation = | Text | 24 character limit | The positive direction for axis 3. For example: “up”. |
| CS axis 3 unit code = | Long integer | EPSG code range is limited to 1–32767, but other database users may add their own code extensions outside of this range. | At least one of EPSG unit code, unit name or unit conversion ratio to standard unit (radian for angle, meter for length, unity for scale) is required. Example conversion ratios: if unit = grad, conversion ratio $\approx 0.01570796\dots$; if unit = International foot, conversion ratio = 0.3048; if unit = unity, conversion ratio = 1.0. |
| CS axis 3 unit name = | Text | 80 character limit, but must be from EPSG Unit of Measure table Name field. | |
| CS axis 3 unit conversion = | Real Number | IEEE double precision. | |

D.1.2 Example Stanzas for Location Data

a) Example of implicit identification of Location Data through a geographic 2D CRS

((SEG: Location Data EPSG Reference ver 3.0))

Location Data Stanza ID = 1
CRS code = 4267
CRS name = NAD27
Dataset version = 6.13

b) Example of implicit identification of Location Data through a projected CRS (i.e. through a Map Grid)

This is the same CRS as described in full in example (e).

((SEG: Location Data EPSG Reference ver 3.0))

Location Data Stanza ID = 2
CRS code = 34020
CRS name = NAD27 / Texas South Central
Dataset version = 6.13

c) Example of implicit identification of Location Data through compound coordinate reference system consisting of projected CRS (map grid) with vertical CRS

This is the same CRS as described in full in example (i).

((SEG: Location Data EPSG Reference ver 3.0))

Location Data Stanza ID = 3
CRS code = 7407
CRS name = NAD27 / Texas North + NGVD29
Dataset version = 6.13

d) Example of implicit identification of Location Data through a compound coordinate reference system consisting of geographic2D CRS with vertical CRS

((SEG: Location Data EPSG Reference ver 3.0))

Location Data Stanza ID = 4
CRS code = 7406
CRS name = NAD27 + NGVD29
Dataset version = 6.13

e) Example of explicit definition of Location Data through a projected CRS (i.e. a map grid)

This is the same CRS as identified implicitly in example (b).

((SEG: LOCATION DATA VER 3.0))

Location Data Stanza ID 5
CRS type = projected

CRS name = NAD27 / Texas South Central
 Geodetic Datum name = North American Datum 1927
 Ellipsoid name = Clarke 1866
 Ellipsoid semi-major axis = 6378206.4
 Semi-major axis unit name = meter
 Ellipsoid inverse flattening = 294.9786982
 Projection name = Texas CS27 South Central zone
 Projection method name = Lambert Conic Conformal (2SP)
 Projection parameter 1 name = latitude of false origin
 Projection parameter 1 value = 27.5
 Projection parameter 1 unit name = sexagesimal DMS
 Projection parameter 2 name = longitude of false origin
 Projection parameter 2 value = -99
 Projection parameter 2 unit name = degree
 Projection parameter 3 name = latitude of first standard parallel
 Projection parameter 3 value = 28.23
 Projection parameter 3 unit name = sexagesimal DMS
 Projection parameter 4 name = latitude of second standard parallel
 Projection parameter 4 value = 30.17
 Projection parameter 4 unit name = sexagesimal DMS
 Projection parameter 5 name = easting at false origin
 Projection parameter 5 value = 2000000.0
 Projection parameter 5 unit name = US survey foot
 Projection parameter 6 name = northing at false origin
 Projection parameter 6 value = 0.0
 Projection parameter 6 unit name = US survey foot
 Coordinate System axis 1 name = X
 CS axis 1 orientation = East
 CS axis 1 unit code = 9003
 CS axis 1 unit name = US Survey foot
 CS axis 1 unit Conversion Ratio = 0.304800609601
 Coordinate System axis 2 name = Y
 CS axis 2 orientation = North
 CS axis 2 unit name = US Survey foot

f) Example of explicit definition of Location Data through a geographic2D CRS

((SEG: LOCATION DATA VER 3.0))

Location Data Stanza ID = 6
 CRS type = geographic 2D
 CRS name = NTF (Paris)
 Geodetic Datum name = Nouvelle Triangulation Francaise (Paris)
 # The following three keyword/value pairs are not needed when Prime Meridian =
 Greenwich.

See examples (a) and (c) for instances where these keyword/value pairs are omitted.

Prime Meridian name = Paris
PM Greenwich longitude = 2.5969213
PM Greenwich longitude unit name = Grad
Ellipsoid name = Clarke 1880 (IGN)
Ellipsoid semi-major axis = 6378249.2
Semi-major axis unit name = meter
Ellipsoid inverse flattening = 293.466021293
Coordinate System axis 1 name = latitude
CS axis 1 orientation = north
CS axis 1 unit name = grad
Coordinate System axis 2 name = longitude
CS axis 2 orientation = east
CS axis 2 unit code = 9105
CS axis 2 unit name = grad
CS axis 2 unit Conversion Ratio = 0.015707963267949

g) Example of explicit definition of Location Data through a geographic3D CRS

((SEG: Location Data ver 3.0))

Location Data Stanza ID = 7
CRS type = geographic 3D
CRS name = WGS 84
Geodetic Datum name = World Geodetic System 1984
Ellipsoid name = WGS 84
Ellipsoid semi-major axis = 6378137.0
Semi-major axis unit name = meter
Ellipsoid inverse flattening = 298.2572236
Coordinate System axis 1 name = latitude
CS axis 1 orientation = north
CS axis 1 unit name = degree
Coordinate System axis 2 name = longitude
CS axis 2 orientation = east
CS axis 2 unit name = degree
Coordinate System axis 3 name = ellipsoidal height
CS axis 3 orientation = up
CS axis 3 unit name = meter

h) Example of explicit definition of Location Data through a geocentric CRS

((SEG: Location Data ver 3.0))

Location Data Stanza ID = 8
CRS type = geocentric
CRS name = WGS 84

| | |
|---------------------------------|------------------------------------------------------------------------|
| Geodetic Datum name = | World Geodetic System 1984 |
| Ellipsoid name = | WGS 84 |
| Ellipsoid semi-major axis = | 6378137.0 |
| Semi-major axis unit name = | meter |
| Ellipsoid inverse flattening = | 298.2572236 |
| Coordinate System axis 1 name = | geocentric X |
| CS axis 1 orientation = | from geocenter to intersection of equator and prime meridian |
| CS axis 1 unit name = | meter |
| Coordinate System axis 2 name = | geocentric Y |
| CS axis 2 orientation = | from geocenter to intersection of equator and meridian of 90 degrees E |
| CS axis 2 unit name = | meter |
| Coordinate System axis 3 name = | geocentric Z |
| CS axis 3 orientation = | from geocenter to north pole |
| CS axis 3 unit name = | meter |

i) Example of explicit definition of Location Data through a compound coordinate reference system: projected CRS (map grid) with vertical CRS

This is the same CRS as identified implicitly in example (c).

((SEG: Location Data ver 3.0))

| | |
|------------------------------------|--------------------------------------|
| Location Data Stanza ID = | 9 |
| CRS type = | compound |
| CRS name = | NAD27 / Texas South Central + NGVD29 |
| Horizontal CRS name = | NAD27 / Texas South Central |
| Vertical CRS name = | NGVD29 |
| Geodetic Datum name = | North American Datum 1927 |
| Ellipsoid name = | Clarke 1866 |
| Ellipsoid semi-major axis = | 6378206.4 |
| Semi-major axis unit name = | meter |
| Ellipsoid inverse flattening = | 294.9786982 |
| Vertical Datum name = | North American Vertical Datum 1929 |
| Projection name = | Texas CS27 South Central zone |
| Projection method name = | Lambert Conic Conformal (2SP) |
| Projection parameter 1 name = | latitude of false origin |
| Projection parameter 1 value = | 27.5 |
| Projection parameter 1 unit name = | sexagesimal DMS |
| Projection parameter 2 name = | longitude of false origin |
| Projection parameter 2 value = | -99 |
| Projection parameter 2 unit name = | degree |
| Projection parameter 3 name = | latitude of first standard parallel |
| Projection parameter 3 value = | 28.23 |
| Projection parameter 3 unit name = | sexagesimal DMS |
| Projection parameter 4 name = | latitude of second standard parallel |

Projection parameter 4 value = 30.17
 Projection parameter 4 unit name = sexagesimal DMS
 Projection parameter 5 name = easting at false origin
 Projection parameter 5 value = 2000000
 Projection parameter 5 unit name = US survey foot
 Projection parameter 6 name = northing at false origin
 Projection parameter 6 value = 0
 Projection parameter 6 unit name = US survey foot
 Coordinate System axis 1 name = X
 CS axis 1 orientation = east
 CS axis 1 unit name = US Survey foot
 Coordinate System axis 2 name = Y
 CS axis 2 orientation = north
 CS axis 2 unit name = US Survey foot
 Coordinate System axis 3 name = height
 CS axis 3 orientation = up
 CS axis 3 unit name = foot

j) Example of implicit definition of Location Data through redundant Geographic and Projected CRSs

In all of the examples (a) through (i) above, one CRS identification is given. This is sufficient when one coordinate tuple is given in the header block. Where two coordinate tuples are given in the header block two CRS definitions are required. In the header blocks, coordinate tuples 1 and 2 will reference these two CRSs. In this example two CRSs are identified implicitly, the first for a geographical (latitude/longitude) coordinate tuple and the second for a projected (map grid) coordinate tuple.

((SEG: Location Data EPSG Reference ver 3.0))

Location Data Stanza ID = 1
 CRS code = 4267
 CRS name = NAD27
 Dataset version = 6.13

((SEG: Location Data EPSG Reference ver 3.0))

Location Data Stanza ID = 2
 CRS code = 34020
 CRS name = NAD27 / Texas South Central
 Dataset version = 6.13

((SEG: EndText))

D.1.3 Location Data Coordinate Transformation stanzas

If during acquisition a coordinate transformation has been applied to derive the coordinates described through a given Location Data stanza or a given Location Data EPSG Reference stanza (for example when the location data has been transformed from the GPS system's WGS 84 coordinates to a local Coordinate Reference System), details of the coordinate transformation which has been applied should be included as a Location Data Coordinate Transformation. A coordinate transformation may be either "single", i.e. directly from source CRS *A* to target CRS *B*, or a "concatenated operation", that is indirectly from *A* to *B* via one or more intermediate CRSs, for example from CRS *A* to CRS *C* to CRS *B*. In either case the final target CRS, i.e. CRS *B*, is that defined in the Location Data or Location Data EPSG Reference stanza.

As with location CRS data the coordinate transformation may be given implicitly⁵ through reference to the EPSG Geodetic Parameter Dataset (Table 1.3) or described explicitly⁶ (Table 1.4).

If more than one CRS is used for a given survey, then an appropriate Location Data Coordinate Transformation Stanza with a unique ID must be given for each of those CRSs. The Location Data Stanza ID for that unique CRS should be referenced in the Location Data Coordinate Transformation Stanza (as shown below).

Multiple Location Data Transformation Stanza IDs may also be used for continuation of stanzas over 3200 bytes to ensure proper continuity and repetition for oversized stanzas.

⁵ Implicit definition of a transformation applied to a given set of coordinates requires the user to specify only the appropriate transformation code and dataset version number of the EPSG dataset from which that transformation definition was obtained. See Table 1.3 for required data for an implicit transformation definition.

⁶ Explicit definition of a transformation applied to a given set of coordinates requires specifying all of the key attributes and parameters necessary to define that transformation. See Table 1.4 for required data in an explicit transformation definition.

Table 1.3 Stanza for implicit identification of Location Data Transformation

| Stanza Header and Keyword | Format | Resolution / Limits | Comment |
|-------------------------------------------------------------------------|---------------|--------------------------------------------------------------------------------------------------------------------------|---------------------------------------------------------------------------------------------------------------------------------|
| ((SEG: Location Data Coordinate Transformation EPSG Reference ver 3.0)) | Text | | Stanza name |
| Location Data Coordinate Transformation Stanza ID = | Long Integer | User-defined. | |
| Location Data Stanza ID = | Long Integer | See tables 1.1 and 1.2. | The Location Data Stanza ID for the CRS that is the target of this transformation. |
| Transformation code = | Long integer | EPSG code range is limited to 1–32767, but other database users may add their own code extensions outside of this range. | The code of Transformation, as given in the EPSG Geodetic Parameter Dataset, www.epsg.org |
| Transformation name = | Text | 80 character limit | The name of the Transformation, as given in the EPSG Geodetic Parameter Dataset, www.epsg.org |
| Dataset version ⁷ = | Text | 80 character limit | The release number for the EPSG Geodetic Parameter Dataset. |

⁷ For all EPSG versions from EPSG v6.0 onward the code itself (without version number) would be sufficient, as code number from v6.0 onward will always remain unique. However, adding the version number is a good bit of insurance.

Table 1.4 Stanza for explicit definition of Location Data Transformation

| Stanza Header and Keyword | Format | Resolution / Limits | Comment |
|----------------------------------------------------------------------------------------------------------------------------------|-----------------------------------------------------------------------|-------------------------------------------------------|------------------------------------------------------------------------------------------------------------------------------------------------------------------------------------------------------------------------------------------------------------------|
| ((SEG: Location Data Coordinate Transformation ver 3.0)) | Text | | Stanza name |
| Location Data Coordinate Transformation Stanza ID = | Long Integer | User-defined. | Normally all seismic work will be done with a single transformation and thus the Stanza ID for this specific transformation would be the only one populated. |
| Location Data Stanza ID = | Long Integer | See tables 1.1 and 1.2. | The Location Data Stanza ID for the CRS that is the target of this transformation. |
| Transformation type = | From enumerated list: transformation concatenated operation | 24 character limit, but must be from enumerated list. | Transformation = a single operation that has been applied to initial coordinates to derive values referred to the CRS identified in the Location Data stanza. Concatenated operation = a set of multiple transformations that have been applied sequentially. |
| Transformation name = | Text | 80 character limit | The name of the Transformation |
| Source CRS name = | Text | 80 character limit | The name of the CRS from which coordinates have been transformed, for example that used within the navigation system (usually "WGS 84"). |
| Target CRS name = | Text | 80 character limit | The name of the CRS to which location data is referred. A Location Data stanza or a Location Data EPSG Reference stanza containing this name must precede this stanza. |
| Transformation version = | Text | 24 character limit | The version of the transformation between the source and target CRSs. |
| <i>The following keywords are additionally required when transformation type = transformation:</i> | | | |
| Transformation method name = | Text | 50 character limit | For example "Geocentric translations", "Position Vector 7-param. Transformation", "Coordinate Frame rotation", "NADCON", "NTv2". |
| <i>Then either (a) the following keyword is additionally required for transformation methods which use grid files:</i> | | | |
| Transformation parameter file name = | 1 or more comma-separated text strings | 254 character limit | Containing as many file names as the method requires. For example for the NTv2 method one file name is required, for the NADCON method two file names are required. |
| <i>Or (b) the following keywords are additionally required for transformation methods other than those which use grid files:</i> | | | |

| Stanza Header and Keyword | Format | Resolution / Limits | Comment |
|-------------------------------------------------------|---------------|--------------------------------------------------------------------------------------------------------------------------|----------------------------------------------------------------------------------------------------------------------------------------------------------------------------------------------------------------------------------------------------------------------------------------------------------------------------------------------------------------------------------------------------------------------------------------------------------------------------------------------------------------------------------------------------------------------------------------------------------------------------------------------------------------------|
| Transformation parameter 1 name = | Text | 80 character limit | <p>The number and name of parameters is dependent upon the transformation method. For example the Position Vector and Coordinate Frame methods the seven parameters required are:</p> <ul style="list-style-type: none"> • X-axis translation • Y-axis translation • Z-axis translation • X-axis rotation • Y-axis rotation • Z-axis rotation • Scale difference <p>See example (a) in A-1.4 below for the three parameters required when the transformation method is Geocentric Translations. See EPSG dataset transformation method table for parameters required for other methods.</p> |
| Transformation parameter 1 value = | Real Number | IEEE double precision. | See EPSG dataset for examples of values / ranges. |
| Transformation parameter 1 unit code = | Long integer | EPSG code range is limited to 1–32767, but other database users may add their own code extensions outside of this range. | <p>At least one of EPSG unit code, unit name or unit conversion ratio to standard unit (radian for angle, meter for length, unity for scale) is required. Example conversion ratios: if unit = degree, conversion ratio $\approx 0.01745329\dots$; if unit = US Survey foot, conversion ratio $\approx 0.3048006096\dots$; if unit = parts per million, conversion ratio = 0.000001.</p> |
| Transformation parameter 1 unit name = | Text | 80 character limit, but must be from EPSG Unit of Measure table Name field. | |
| Transformation parameter 1 unit conversion ratio = | Real Number | IEEE double precision. | |
| : : | | | Repeat above sequence for each transformation parameter |
| Transformation parameter n name = | Text | 80 character limit | |
| Transformation parameter n value = | Real Number | IEEE double precision. | See EPSG dataset for examples of values / ranges. |
| Transformation parameter n unit code = | Long integer | EPSG code range is limited to 1–32767, but other database users may add their own code extensions outside of this range. | <p>At least one of EPSG unit code, unit name or unit conversion ratio to standard unit (radian for angle, meter for length, unity for scale) is required. Example conversion ratios: if unit = grad, conversion ratio $\approx 0.01570796\dots$; if unit = International foot, conversion ratio =</p> |

| Stanza Header and Keyword | Format | Resolution / Limits | Comment |
|---------------------------------------------------------------------------------------------------------------------------------------------------------------------------------------------------------|-------------|-----------------------------------------------------------------------------------|------------------------------------------------------------------------------------------------------------------------------------------------------------------------------|
| Transformation parameter n unit name = | Text | 80 character limit, but must be from EPSG Unit of Measure table Name field. | 0.3048; if unit = parts per million, conversion ratio = 0.000001. |
| Transformation parameter n unit conversion ratio = | Real Number | IEEE double precision. | |
| <i>The following keywords are additionally required when transformation type = concatenated operation. They should be repeated in a block for every step with the step counter m being incremented:</i> | | | |
| Concatenated transformation step = | Integer | Integer (typically between 1 and 4) | The value <i>m</i> is used in the following keywords. |
| Step <i>m</i> source CRS name = | Text | 80 character limit | The name of the CRS used within the navigation system (usually "WGS 84"). |
| Step <i>m</i> target CRS name = | Text | 80 character limit | The name of the CRS to which location data is referred. A Location Data stanza or a Location Data EPSG Reference stanza containing this name must precede this stanza. |
| Step <i>m</i> transformation version = | Text | 24 character limit | The version of the transformation between the source and target CRSs. |
| Step <i>m</i> transformation method name = | Text | 50 character limit | For example "Geocentric translations", "Position Vector 7- param. Transformation", " Coordinate Frame rotation", "NADCON", "NTv2". |
| <i>Then either (a) the following keyword is additionally required for steps using transformation methods which use grid files:</i> | | | |
| Step <i>m</i> transformation parameter file name 1 = | Text | 254 character limit | Containing primary file name as the method requires. |
| | | | Repeat above sequence for each transformation parameter |
| Step <i>m</i> transformation parameter file name <i>n</i> = | Text | 254 character limit | Containing "nth" file name required by specific method. For the NTv2 method one file name is required, for the NADCON method two file names are required. |
| <i>Or (b) the following keywords are additionally required for steps using transformation methods other than those which use grid files:</i> | | | |

| Stanza Header and Keyword | Format | Resolution / Limits | Comment |
|------------------------------------------------------------------------|--------------|--------------------------------------------------------------------------------------------------------------------------|----------------------------------------------------------------------------------------------------------------------------------------------------------------------------------------------------------------------------------------------------------------------------------------------------------------------------------------------------------------------------------------------------------------------------------------------------------------------------------------------------------------------------------------------------------------------------------------------------------------------------------------------------------------------|
| Step <i>m</i> transformation parameter 1 name = | Text | 80 character limit | <p>The number and name of parameters is dependent upon the transformation method. For example the Position Vector and Coordinate Frame methods the seven parameters required are:</p> <ul style="list-style-type: none"> • X-axis translation • Y-axis translation • Z-axis translation • X-axis rotation • Y-axis rotation • Z-axis rotation • Scale difference <p>See example (a) in A-1.4 below for the three parameters required when the transformation method is Geocentric Translations. See EPSG dataset transformation method table for parameters required for other methods.</p> |
| Step <i>m</i> transformation parameter 1 value = | Real Number | IEEE double precision. | See EPSG dataset for examples of values / ranges. |
| Step <i>m</i> transformation parameter 1 unit code = | Long integer | EPSG code range is limited to 1–32767, but other database users may add their own code extensions outside of this range. | At least one of EPSG unit code, unit name or unit conversion ratio to standard unit (radian for angle, meter for length, and unity for scale) is required. |
| Step <i>m</i> transformation parameter 1 unit name = | Text | 80 character limit, but must be from EPSG Unit of Measure table Name field. | Example conversion ratios: if unit = degree, conversion ratio $\approx 0.01745329\dots$; if unit = US Survey foot, conversion ratio $\approx 0.3048006096\dots$; if unit = parts per million, conversion ratio = 0.000001. |
| Step <i>m</i> transformation parameter 1 unit conversion ratio = | Real Number | IEEE double precision. | |
| : : | | | Repeat above sequence for each transformation parameter |
| Step <i>m</i> transformation parameter n name = | Text | 80 character limit | |
| Step <i>m</i> transformation parameter n value = | Real Number | IEEE double precision. | See EPSG dataset for examples of values / ranges |

| Stanza Header and Keyword | Format | Resolution / Limits | Comment |
|------------------------------------------------------------------|---------------|--------------------------------------------------------------------------------------------------------------------------|-------------------------------------------------------------------------------------------------------------------------------------------------------------------------------------------------------------------------------------------------------------------------------------------------------------------------------------------------------------------|
| Step <i>m</i> transformation parameter n unit code = | Long integer | EPSG code range is limited to 1–32767, but other database users may add their own code extensions outside of this range. | At least one of EPSG unit code, unit name or unit conversion ratio to standard unit (radian for angle, meter for length, unity for scale) is required. Example conversion ratios: if unit = grad, conversion ratio \approx 0.01570796...; if unit = International foot, conversion ratio = 0.3048; if unit = parts per million, conversion ratio = 0.000001. |
| Step <i>m</i> transformation parameter n unit name = | Text | 80 character limit, but must be from EPSG Unit of Measure table Name field. | |
| Step <i>m</i> transformation parameter n unit conversion ratio = | Real Number | IEEE double precision. | |

D.1.4 Example Stanzas for Location Data Transformation

k) Example of implicit identification of Location Data Coordinate Transformation through a single transformation

```
((SEG: Location Data Coordinate Transformation EPSG Reference ver 3.0))
Location Data Coordinate Transformation Stanza ID = 10
Location Data Stanza ID = 1
Transformation code = 15853
Transformation name = NAD27 to WGS 84 (81)
Dataset version = 6.13
```

l) Example of implicit identification of Location Data Coordinate Transformation through a concatenated operation

```
((SEG: Location Data Coordinate Transformation EPSG Reference ver 3.0))
Location Data Coordinate Transformation Stanza ID = 11
Location Data Stanza ID = 1
Transformation code = 8635
Transformation name = NAD27 to NAD83(CSRS) (3)
Dataset version = 6.13
```

m) Example of explicit definition of Location Data Transformation through a single transformation with a method using parameters

```
((SEG: Location Data Coordinate Transformation ver 3.0))
Location Data Coordinate Transformation Stanza ID = 12
Location Data Stanza ID = 1
Transformation type = transformation
Transformation name = WGS 84 to NAD27
Source CRS name = WGS 84
Target CRS name = NAD27
Transformation version = JECA-Usa GoM C
Transformation method name = Geocentric translations
Transformation parameter 1 name = X-axis translation
Transformation parameter 1 value = 7
Transformation parameter 1 unit name = meter
Transformation parameter 2 name = Y-axis translation
Transformation parameter 2 value = -151
Transformation parameter 2 unit name = meter
Transformation parameter 3 name = Z-axis translation
Transformation parameter 3 value = -175
Transformation parameter 3 unit name = meter
```

n) Example of explicit definition of Location Data Transformation through a single transformation with a method using grid files

((SEG: Location Data Coordinate Transformation ver 3.0))

Location Data Coordinate Transformation Stanza ID = 13
Location Data Stanza ID = 18
Transformation type = transformation
Transformation name = NAD27 to NAD83 (1)
Source CRS name = NAD27
Target CRS name = NAD83
Transformation version = NGS-Usa Conus
Transformation method name = NADCON
Transformation parameter file name 1 = conus.las,
Transformation parameter file name 2= conus.los

o) Example of explicit definition of Location Data Transformation through a concatenated operation

((SEG: Location Data Coordinate Transformation ver 3.0))

Location Data Coordinate Transformation Stanza ID = 14
Location Data Stanza ID = 1
Transformation type = Concatenated operation
Transformation name = NAD83(CSRS) to NAD27
Source CRS name = NAD83(CSRS)
Target CRS name = NAD27
Transformation version = EPSG-Can AB
Concatenated transformation step = 1
Step 1 transformation step name = NAD83(CSRS) to NAD83
Step 1 source CRS = NAD83(CSRS)
Step 1 target CRS = NAD83
Step 1 transformation version = AB Env-Can AB
Step 1 transformation method name = NTV2
Step 1 transformation parameter file name = AB_CSRS.gsb
Concatenated transformation step = 2
Step 2 transformation step name = NAD83 to NAD27
Step 2 source CRS = NAD83
Step 2 target CRS = NAD27
Step 2 transformation version = GC-Can NT2
Step 2 transformation method name = NTV2
Step 2 transformation parameter file name = NTV2_0.GSB

Appendix E: Examples and Calculations

E.1 Samples per scan type

Note:

This example is no longer valid as SEG-D rev 3.0 and above no longer has a base scan interval, and hence no longer has a “samples per scan” value. The example is mainly here to support storing old formatted data in SEG-D rev 3.0+.

$$S/S = \sum_1^{CS} C/S \times 2^{s/c}$$

where

S/S = samples per scan type

C/S = channels in this channel set (channel set descriptor Bytes 21 to 23)

$2^{s/c}$ = samples per channel (in this channel set)

CS = number of channel sets in this scan type (general header #1 Byte 29 or general header #2 Byte 4 and 5)

For example, for a 2-msec base scan interval with 4 auxiliary channels at 2 msec, 96 channels at 2 msec and 12 channels at 1/2 msec. There are three channel sets, so CS = 3.

$$S/S = \begin{array}{c} C/S \times 2^{s/c} \\ cs = 1 \end{array} \quad | \quad \begin{array}{c} + C/S \times 2^{s/c} \\ cs = 2 \end{array} \quad | \quad + \dots$$

$$S/S = 4 \times 1 + 96 \times 1 + 12 \times 4$$

$$S/S = 4 + 96 + 48 = 148$$

Note that all scan types must have the same number of data samples.

E.2 Skew fields per scan type

Note:

This example is no longer valid as SEG-D rev 3.0 and above no longer has a base scan interval, and hence no longer has a “samples per scan” value. The example is mainly here to support storing old formatted data with skew blocks in SEG-D rev 3.0+.

$$SK = \frac{S/S}{32} \quad (\text{If the quotient is not a whole number, round up to the next largest whole number})$$

where

SK = skew fields (of 32 bytes each) per scan type (general header Byte 30)

S/S = samples per scan (Appendix E1)

Substituting for S/S from Appendix E.1:

$$SK = \frac{1}{32} \sum_1^{CS} C/S \times 2^{s/c}$$

(If the quotient is not a whole number, round up to the next largest whole number.)

where

CS = the number of channel sets in each scan type (general header #1 Byte 29 or #2 Byte 4 and 5)

C/S = channels in this channel set (channel set descriptor Bytes 21 to 23)

$2^{s/c}$ = samples per channel in this channel set.

For example, for a 2-msec base scan with 4 auxiliary channels at 2 msec, 96 channels at 2 msec and 12 channels at ½ msec

$$SK = \frac{4 \times 1 + 96 \times 1 + 12 \times 4}{32}$$

$$= \frac{148}{32} = 4 \frac{20}{32} \text{ roundup} = 5 \text{ fields of 32 bytes each}$$

E.3 Filter slope calculation

Modern filters may not have a constant slope, so it is necessary to define this parameter. The slope is defined as the asymptote of effective performance as it would be in a constant slope filter. This slope is zero dB attenuation at the cut-off frequency and a specific attenuation at the beginning of the stop band. The chosen values are 40 dB for a low-cut filter and 60 dB for an anti-alias filter.

Low-cut filter slope calculation.

$$LS = \frac{40}{\log_2 f_{LCO}/f_{40}} = \frac{40}{3.322 \log_{10} f_{LCO}/f_{40}} = \frac{12.04}{\log_{10} f_{LCO}/f_{40}}$$

LS = low-cut filter slope (channel set descriptor Bytes 19 and 20),

f₄₀ = the frequency of 40 dB low-cut filter attenuation,

f_{LCO} = low-cut filter cut-off frequency usually 6 or 12 dB attenuation.

Alias-filter slope calculation.

$$AS = \frac{60}{\log_2 f_{60}/f_{ACO}} = \frac{60}{3.322 \log_{10} f_{60}/f_{ACO}} = \frac{18.06}{\log_{10} f_{60}/f_{ACO}}$$

AS = alias filter slope (channel set descriptor Bytes 15 and 16)

f₆₀ = the frequency of 60 dB alias-filter attenuation

f_{ACO} = alias-filter cut-off frequency usually 3 or 6 dB attenuation

E.4 SEG-D file storage on non-tape media

Modern acquisition and processing systems commonly require storing SEG-D data on disk. These are a few examples of how this can be done:

Raw disk copy of SEG-D records

As stated in chapter 3, starting with Revision 2, SEG-D data are treated as a stream of bytes. When storing Rev 3.0 data on tape, tape block and file marks are inserted at points defined by the manufacturer.

Interpretation of data is done on the raw byte data stream. It is important to maintain the byte stream view when storing SEG-D on disk as well, such that decoding and encoding of data is performed in the same way, independent of its storage format. (For fixed blocksize devices, trailing padding at the end of some blocks slightly violates this treatment and we strongly recommend that such data should be first converted, as detailed below, from FIXREC to RECORD format before storing on disk or transmitting through a network.)

From the definitions in chapter 3 it follows that a disk file is a storage media similar to a tape, hence a tape label must be placed at the beginning of the file, followed by a set of SEG-D records. A TOC indexing file may or may not be a part of the file.

A good solution is to use the filename as indication of the contents of the SEG-D records in the file. To speed up access to SEG-D data on disk, storing only one SEG-D record per file may be the best option with, for example, the file name being `<filename>.segd` or `<linename>_<filename>.segd`.

The fields in the Tape Label should be set thusly:

- Storage unit structure will be RECORD
- Maximum block size will be 1
- Serial Number must be unique, however as disk storage is normally temporary, making it unique within the disk might be sufficient. For single record files, using a combination of file number and e.g. line/sequence/swath number might be a good solution. (For temporary storage, if the Serial Number is not used as part of an indexing system, the producer has flexibility in defining its contents.)

The file layout:

[Tape Label|SEG-D Header|Trace Data|General Trailer|EOF]

The advantage of this solution is it allows direct access of data on disk (through a memory mapped file) in the same way as data are accessed in memory. For certain tasks, especially quality control inspection, this may speed up the process with a factor of 10 or 100.

E.5 SEG-D record index interpretation for marine, land, seabed, transition-zone, and VSP surveys

SEG-D uses six indices to uniquely assign a trace with a unique logical position within the record. The interpretation of indices depends on the type of survey. The basic difference is between surveys where the receivers are stationary (land/seabed), and where the receivers are moving (towed marine). Transition zone surveys use a combination of the two. Other conceivable combinations are seabed and towed marine, VSP (vertical seismic profile, i.e. receivers in one or more boreholes) and land/marine/seabed/TZ. The indices need to be valid for all these survey types, including combinations.

The indices are:

- Line

- Point
- Point Index
- Group Index
- Depth Index
- Reshoot Index

Indices exist for both source (i.e. Source Point, Source Line), and receiver (i.e. Receiver Point, Receiver Line).

The *Group Index* is used to indicate a trace belonging to a set of traces that need to be processed as a unit (and are placed at the same position), e.g. three-component data that need to be rotated together.

The *Reshoot Index* is used to indicate a trace has been recorded earlier, and the data with the highest Reshoot Index should be used in processing (normally).

Towed marine survey

A Marine survey is normally divided up in lines, and the survey is acquired by one or more vessels towing one or more sources and one or more streamers. The lines are normally assigned an integer number. The example below shows a complex survey using two streamer vessels with two sources each, and one source vessel travelling behind one of the streamer vessels.

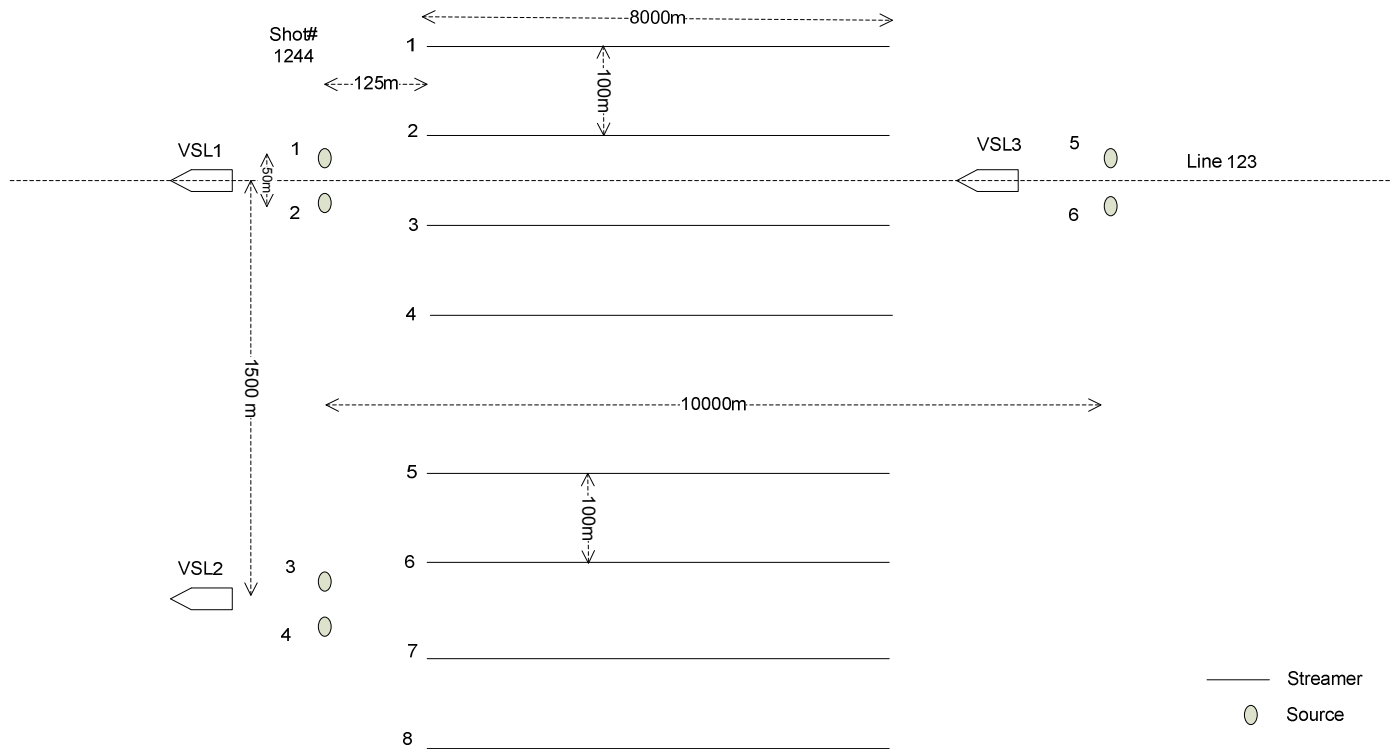

Figure showing a complex vessel configuration for a marine seismic survey. Note, figure is not to scale

Source / receiver line number

The receiver and source line number is give by the line number, in this case 123. In this example, the fractional part of the source /receiver number will be used to indicate the nominal position of the equipment.

Using a pure logical numbering scheme is allowed, i.e. there are 12 separate equipment lines in the figure (8 streamer and 4 source). Equipment is e.g. allocated line number in steps of 0.5, starting counting from 123.0. Streamer 1 has receiver line 123.0, Streamer 2 123.05, Source 1 and 5 has source line 123.1, Source 2 and 6 123.15, Streamer 8 has 123.55.

However for this example, the logical positions are selected to reflect the actual offsets. The offset between the outer streamers (1 and 8) are 1300 meters. 1 meter is selected to be 0.0005 logical units. Assuming increasing line numbers downwards in the figure, Streamers are assigned the following line numbers:

1: 122.925, 2: 122.955, 3: 123.025, 4: 123.075, 5: 123.675, 6: 123.725, 7: 123.775, 8: 123.725.

Sources are assigned the following source line numbers:

1: 122.9875, 2: 123.0125, 4: 123.4875, 5: 123.5125, 5: 122.9875, 6: 123.0125

It is worth noting here that the number resolution in the receiver/source line numbers is not very high, so the numbers above will be approximate.

Source / receiver point number

A similar strategy is used for source/receiver point number. The distance between sources 1 and 5 is 10000 meters. Receivers in the streamers are spaced at 12.5 meter intervals. 12.5 meters is chosen to be 1/1024 logical point units (The reason behind selecting 1/1024 as a unit is that this number is well represented in the format). The marine acquisition line is divided up into shots (source events), with 25 meter spacing, the shot# in the figure is 1244. The numbering starts from the first equipment (sources 1-4), counting backwards until the last equipment (sources 5-6). The logical numbering will be the same independent of the line direction (upline, i.e. shot# increasing, or downline, i.e shot# decreasing).

Sources 1-4 get Source Point Number 1244.0, sources 5-6 1244.78125.

Receiver 1 (on all streamers) is assigned Receiver Point Number 1244.00977, Receiver 2 1244.01074, Receiver 3 1244.01172, ... Receiver 640 1244.63379

The Receiver Point Index will always be 1 for the marine survey.

Note: The source/receiver line/point number will only reflect the nominal position, actual position due to e.g. streamer feather is not considered when determining the logical position determined by the indices. If actual position is needed, the position may be stored in Position Blocks in Trace Headers.

Land

Land seismic surveys have been using Source and Receiver lines for many years, so no large example will be give here. SEG-D may be used to map in the numbers currently used.

Seabed

Seabed surveys are a combination of a Land and Marine survey, where sensors are placed on the sea floor, and a source vessel is moving around in the area, usually along Source Lines. Seabed covers several operations, like seismic sensors placed on the sea floor temporarily in the form of streamers or separate sensor units, permanently around installations, or electrical / magnetic sensors (EM survey).

The sensors are deployed in a grid defined by the Receiver Line and Point Numbers, similar to a Land survey.

Sources are moving in Source Lines similar to the example for Marine survey, and are assigned indices accordingly. For continuous source efforts, like EM surveys, where the source fires continually, it is allowed to set the Source Point Number to 0 if it does not fit at all. However, it is highly recommended to determine a logical numbering scheme that allows the use of Source Point Number. This is one of the reasons why splitting up the data into smaller records are recommended, e.g. to match the cycle of the source (see E.10 Electromagnetic (EM) survey) for more details.

Transition-zone

Transition zone may be viewed as a combination survey being parts Marine and parts Land survey. Indices are assigned using Marine or Land methods where appropriate.

Downhole seismic / Vertical seismic profile

This covers all survey types where seismic sensors are inserted down a well. The sensors may be a dedicated seismic string, or acquired as part of other downhole equipment. The survey may be a normal seismic survey, Land or Marine, where the downhole data is acquired in conjunction with a larger system, or a dedicated well centric survey, like a walkaway vertical seismic profile. The Source Line /Point Number is assigned as normal, even with well centric surveys, the source moves in predetermined line.

Receiver Line / Point Number is assigned by giving the all receivers in the well the same Receiver Line and Receiver Point Number, and use the Depth Index to indicate the order downhole. If the downhole string contains more than 255 receivers, the Receiver Point Index is used to extend the numerical range of the Depth Index. This allows a maximum of about 65000 receivers down a well. It is worth noting that all receivers in a well are assigned the same Receiver Line /Point Number, even if the well is horizontal.

E.6 Trace edit example

Example of Trace Edits in General Trailer, built up by data from several systems, here by the acquisition system ACQSYS, the quality control system AQC, and the positioning system NAVPOS. The edit block may be extended by the different systems, or separate edit blocks may be created.

```
V SEGD Trace Edit v1.0
S 12:34:55 12-JAN-2007
W ACQSYS v2.2.3 build 231, M/S Unsinkable II
C These are the edits performed by online acquisition
H Killed traces
A killed trace
X 1;2;1-4
X 1;5;23,48-50,423
X 1;8;345
X 1;5-14;1
```

```

E END Killed traces
H Weak trace detection
A Seismic trace RMS < 1 uB
P SEIS_RMS(1,0.014)
R 1;5-14;1-558
X 1;3;123-135
X 1;15;33,55,231-234
E END Weak trace detection
S 14:15:00 12-JAN-2007
W AQC v6.4, operator John D. Operator
C These edits done by the online Quality Control system
H Noisy trace detection
A NOISY_TRACE(12,0.65)
C Noisy trace detection by comparing neighboring traces
C and performing frequency content analysis
R 1;5-14;1-558
X 1;6;1-15,234-238
X 1;8;1-15
E END Noisy trace detection
H Manual edits
A Manual edits
C Manual edits performed by operator
Y EXCLUDE
X 1;9;550-558
E END Manual edits
S 15:05:00 12-JAN-2007
W NAVPOS v1.2
C Edits done by positioning system
H Position verification
A GPS_VERIFY(4) GPS position quality verification
Y WARNING
X 1;14;1-558
C Comments entered by navigator:
C GPS positions for streamer 10 unreliable for shots 1201-1243
E END Position verification
T END SEGD Trace Edit

```

E.7 Source information in General Header or Trace Header

Source IDs/sets

Each source needed to be recorded must be assigned an ID, the same is required of any combined set of sources.

Examples:

1. A SEG-D record contains four vibrators firing as a group. The record contains Source Description blocks for each of the single vibrators, and the combined source group. The four vibrators have ids 2,12,13, and 16, each belonging to source set 101 (i.e. vibrator group 101). The combined source is assigned the id 101, and it does not belong to any source set, i.e. the source set is set to 0.

| <i>Source id</i> | <i>Source set</i> |
|------------------|-------------------|
| 2 | 101 |
| 12 | 101 |
| 13 | 101 |
| 16 | 101 |
| 101 | 0 |

For each of the vibrators the position is logged together with a auxillary trace for the baseplate movement. To capture the status and actual firing time for each individual vibrator, an Additional Source Info block is used. For the vibratorgroup the combined status is stored in an Additional Source Info block. The following source blocks are therefore stored as part of General Header (each box is one 32 byte block):

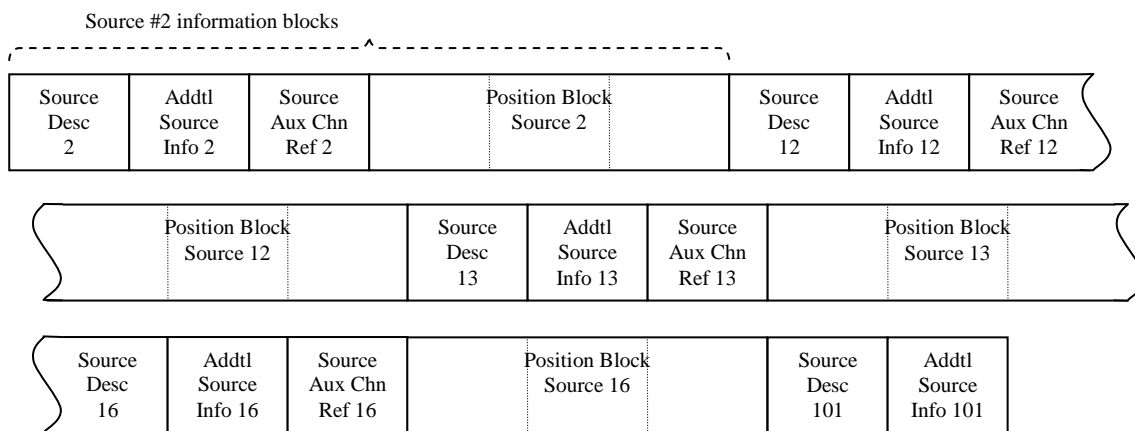

2. A marine airgun source is made up of three sub-strings, each consisting of three airguns (one cluster, and two single guns). The record contains Source Description blocks for each of the airguns, one for each of the substrings, and one for the combined source. The single/cluster guns have ids 1,2,3 (substring 1), 4,5,6 (substring 2), 7,8,9 (substring 3). Numbering should be starboard to port, front to back. The substrings are assigned the ids 51,52,53, and the combined source id 101. The combined source have set id 101 (starboard source is 101, the port source has set id 102, source id 102). The substrings have set ids 51,52,53.

| <i>Source id</i> | <i>Source set</i> |
|------------------|-------------------|
| 1 | 51 |
| 2 | 51 |
| 3 | 51 |
| 4 | 52 |
| 5 | 52 |
| 6 | 52 |
| 7 | 53 |
| 8 | 53 |
| 9 | 53 |
| 51 | 101 |
| 52 | 101 |
| 53 | 101 |

| | |
|-----|---|
| 101 | 0 |
|-----|---|

To be able to see which sources belongs to which source sets, it is important to give the source set, and the combined source ids the same value. This means SEG-D rev 3.0 supports up to 255 different single sources and source sets/groups.

Source information should match SPS definitions.

To be able to cope with multiple source events during the record, Source Information blocks can be recorded as part of the Trace Extension Header (instead of in the General Header). The Additional Source Info block *must* then be present for each Source Information block, and the timestamp (bytes 1–8) filled in properly to indicate which sample the source event happened. The relevant source description blocks must also be inserted into all traces relating to source (source signatures, baseplate measurements, raw nearfield hydrophone data etc.), though they may also be recorded as part of any other (seismic/auxiliary) trace.

E.8 Extended Recording Mode example

Extended recording mode is mostly designed for situations where lack of resources makes creation of multiple SEG-D records a complicated or impossible task, e.g. in embedded systems where memory resources or memory model making storing meta-information intermixed with the data difficult.

Extended recording mode allows data to be recorded in blocks of up to 4,294,967,295 samples, containing a small trace header (84 byte minimum) followed by up to 4,294,967,295 samples of data.

Consider the following sensor node:

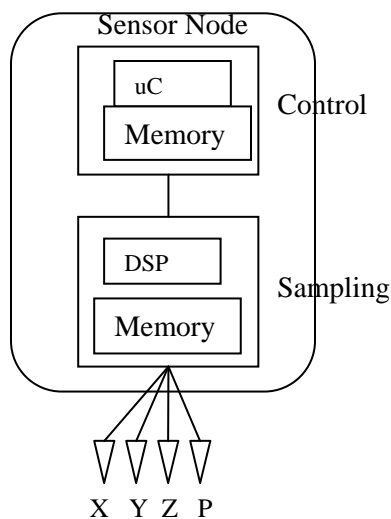

The node contains one microcontroller (μC) with attached memory for control, monitoring, quality control and external communication, and one digital signal processor (DSP) with attached memory for sampling and data filtering from 4 sensors (a 3 component accelerometer and one hydrophone).

The node is deployed on the sea floor, and will remain there for a maximum of two weeks (1,209,600 seconds) before being picked up. Extended recording mode allows up to 65535 channelsets (or time blocks) to be acquired in one record, each channelset being up to 4,294,967,295 samples long. As the node has 4 different channel types, which have to be stored in separate channelsets, the available number of time blocks in extended Recording mode is $65535/4=16383$. To get the minimum time block/channelset length for this system we calculate $1209600/16383 = 73.8$ seconds

One may then safely decide to choose a trace size of 120 seconds. This creates a suitable sized trace which fit the memory model of the DSP well, has a good safety margin (can be deployed for a maximum of 22 days), and has a good overhead to data ratio. In addition the system is created such that in case of a memory problem, only 120 consecutive seconds of data will be lost at a time.

The microcontroller is responsible for creating the SEG-D record header and keep it in memory during the acquisition. Whenever a new channelset is needed, the DSP notifies the microcontroller, which creates the 4 channelset descriptors. The DSP creates 4 new trace headers in its memory, each consisting of a Trace Header (20 bytes), Trace Header Extension #1 (32 bytes), and a Timestamp Header (32 byte). It then starts writing trace data into the new traces.

The microcontroller monitors several other sensors during the acquisition, including temperature, box pressure, leakage sensor, power status, compass readings, tilt/orientation measurements, clock drift etc. This information is stored in the SEG-D record Extended Header in a manufacturer specific format.

When the data is downloaded from the node, the microcontroller first sends the header data stored in its memory, then reads the trace data from the DSP such that the download software receives a complete SEG-D record.

E.9 SEG-D timestamp calculation

```
/* SEG-D UTC <--> GPS conversion

 * The following is ANSI C++ code.
 * It should be easily translated to most other common languages like Java, C, C#, Fortran, Perl
 */

#include <stdio.h>
#include <limits.h>
#include <stdlib.h>

#if LONG_MAX <= 2147483647L
#if defined(_MSC_VER)
typedef __int64 Timestamp;
#define TSDECL(x) x##i64
#define tsfmt "%I64d"
#else
typedef long long Timestamp;
#define TSDECL(x) x##LL
#define tsfmt "%lld"
#endif
#else

```

```

typedef long Timestamp;
#define TSDECL(x) x##L
#define tsfmt "%ld"
#endif

const int dayArr[2][12] = { { 31, 28, 31, 30, 31, 30, 31, 31, 30, 31, 30, 31 },
                             { 31, 29, 31, 30, 31, 30, 31, 31, 30, 31, 30, 31 } };

const char *monthArr[12] = { "Jan", "Feb", "Mar", "Apr", "May", "Jun",
                              "Jul", "Aug", "Sep", "Oct", "Nov", "Dec" };

class Utc {
public:
    int year;
    int month; /* 1..12 */
    int day; /* 1..31 */
    int hour; /* 0..23 */
    int minute; /* 0..59 */
    int sec; /* 0..60 60=leap second */
    int microsec; /* 0-999999 fraction of sec */

    Utc( int y, int m, int d, int h, int min, int s, int us ) :
        year(y), month(m), day(d), hour(h), minute(min), sec(s), microsec(us) {}

    Utc() {}

    const char* toString() const {
        /* not threadsafe code */
        static char str[28];
        sprintf( str, "%2d %s %4d %02d:%02d:%02d.%06d",
                day,monthArr[month-1],year,hour,minute,sec,microsec);
        return str;
    }
};

struct DayLeapsec {
    int days; /* days since 6 jan 1980, may be negative */
    int leapsecs;
};

struct TimestampLeapsec {
    Timestamp timestamp;
    int leapsecs;
};

struct TimestampJan1Year {
    int year;
    Timestamp timestamp;
};

#define NLEAP (sizeof(dayLeapArr)/sizeof(dayLeapArr[0]))

const DayLeapsec dayLeapArr[] = {
    {-3657, -9}, /* 1 jan 1970 */
    {-2745, -8}, /* 1 jul 1972 */
    {-2561, -7}, /* 1 jan 1973 */
    {-2196, -6}, /* 1 jan 1974 */
    {-1831, -5}, /* 1 jan 1975 */
    {-1466, -4}, /* 1 jan 1976 */
    {-1100, -3}, /* 1 jan 1977 */
    {-735, -2}, /* 1 jan 1978 */
    {-370, -1}, /* 1 jan 1979 */
    {-5, 0}, /* 1 jan 1980 */
    {542, 1}, /* 1 jul 1981 */
    {907, 2}, /* 1 jul 1982 */
    {1272, 3}, /* 1 jul 1983 */
    {2003, 4}, /* 1 jul 1985 */
    {2917, 5}, /* 1 jan 1988 */
    {3648, 6}, /* 1 jan 1990 */
    {4013, 7}, /* 1 jan 1991 */
    {4560, 8}, /* 1 jul 1992 */
    {4925, 9}, /* 1 jul 1993 */
    {5290, 10}, /* 1 jul 1994 */
    {5839, 11}, /* 1 jan 1996 */
};

```

```

    {6386, 12}, /* 1 jul 1997 */
    {6935, 13}, /* 1 jan 1999 */
    {9492, 14}, /* 1 jan 2006 */
    {10588, 15} /* 1 jan 2009 */
};

```

```

const TimestampLeapsec tsLeapArr[] = {
    {TSDECL(-315964809000000) , -9},
    {TSDECL(-237168008000000) , -8},
    {TSDECL(-221270407000000) , -7},
    {TSDECL(-189734406000000) , -6},
    {TSDECL(-158198405000000) , -5},
    {TSDECL(-126662404000000) , -4},
    {TSDECL( -950400030000000) , -3},
    {TSDECL( -635040020000000) , -2},
    {TSDECL( -319680010000000) , -1},
    {TSDECL(  -432000000000) , 0},
    {TSDECL( 468288010000000) , 1},
    {TSDECL( 783648020000000) , 2},
    {TSDECL( 1099008030000000) , 3},
    {TSDECL( 1730592040000000) , 4},
    {TSDECL( 2520288050000000) , 5},
    {TSDECL( 3151872060000000) , 6},
    {TSDECL( 3467232070000000) , 7},
    {TSDECL( 3939840080000000) , 8},
    {TSDECL( 4255200090000000) , 9},
    {TSDECL( 4570560100000000) , 10},
    {TSDECL( 5044896110000000) , 11},
    {TSDECL( 5517504120000000) , 12},
    {TSDECL( 5991840130000000) , 13},
    {TSDECL( 8201088140000000) , 14},
    {TSDECL( 9148032150000000) , 15}
};

```

```

const TimestampJanlYear tsJanlYearArr[] = {
    { 1970, TSDECL(-315964809000000) },
    { 1971, TSDECL(-284428809000000) },
    { 1972, TSDECL(-252892809000000) },
    { 1973, TSDECL(-221270407000000) },
    { 1974, TSDECL(-189734406000000) },
    { 1975, TSDECL(-158198405000000) },
    { 1976, TSDECL(-126662404000000) },
    { 1977, TSDECL(-950400030000000) },
    { 1978, TSDECL(-635040020000000) },
    { 1979, TSDECL(-319680010000000) },
    { 1980, TSDECL(-432000000000) },
    { 1981, TSDECL(311904000000000) },
    { 1982, TSDECL(627264010000000) },
    { 1983, TSDECL(942624020000000) },
    { 1984, TSDECL(1257984030000000) },
    { 1985, TSDECL(1574208030000000) },
    { 1986, TSDECL(1889568040000000) },
    { 1987, TSDECL(2204928040000000) },
    { 1988, TSDECL(2520288050000000) },
    { 1989, TSDECL(2836512050000000) },
    { 1990, TSDECL(3151872060000000) },
    { 1991, TSDECL(3467232070000000) },
    { 1992, TSDECL(3782592070000000) },
    { 1993, TSDECL(4098816080000000) },
    { 1994, TSDECL(4414176090000000) },
    { 1995, TSDECL(4729536100000000) },
    { 1996, TSDECL(5044896110000000) },
    { 1997, TSDECL(5361120110000000) },
    { 1998, TSDECL(5676480120000000) },
    { 1999, TSDECL(5991840130000000) },
    { 2000, TSDECL(6307200130000000) },
    { 2001, TSDECL(6623424130000000) },
    { 2002, TSDECL(6938784130000000) },
    { 2003, TSDECL(7254144130000000) },
    { 2004, TSDECL(7569504130000000) },
    { 2005, TSDECL(7885728130000000) },
    { 2006, TSDECL(8201088140000000) },
    { 2007, TSDECL(8516448140000000) },
};

```

```

    { 2008, TSDECL(883180814000000) },
    { 2009, TSDECL(914803215000000) },
    { 2010, TSDECL(946339215000000) },
    { 2011, TSDECL(977875215000000) }
};

int isLeap( int year ) {
    return (((year) % 4) == 0 && (((year) % 100) != 0 || ((year) % 400) == 0));
}

int month_dayToJulian( int day, int month, int leapIX ) {
    int julian=day;
    for( int i=0; i<(month-1); i++ ) julian += dayArr[leapIX][i];
    return julian;
}

int daysSinceT0( int year, int julianDay ) {
    int days=0;
    if( year >= 1980 ) {
        days=julianDay-6; /* correct for starting day 6 jan 1980 */
        for( int y=1980; y<year; y++ )
            days += 365+isLeap(y);
    } else {
        days = julianDay - 365 - isLeap(year) - 6;
        for( int y=1979; y>year; y-- )
            days -= 365+isLeap(y);
    }
    return days;
}

int leapSecs( int daysSinceT0 ) {
    for( int i=NLEAP-1; i>=0; i-- ) {
        if(daysSinceT0 >= dayLeapArr[i].days ) {
            /* fprintf(stdout, "leapSecs: %d\n", dayLeapArr[i].leapsecs); */
            return dayLeapArr[i].leapsecs;
        }
    }
    fprintf(stderr, "Illegal number in leapSec calculation, is date after 1970?\n");
    return 0; /* should never happen with legal SEG-D timestamps, throw exception here */
}

int leapSecs( Timestamp ts ) {
    for( int i=NLEAP-1; i>=0; i-- ) {
        if(ts >= tsLeapArr[i].timestamp ) {
            fprintf(stdout, "leapSecs: %d\n", tsLeapArr[i].leapsecs);
            return tsLeapArr[i].leapsecs;
        }
    }
    fprintf(stderr, "Illegal number in leapSec calculation, is date after 1970?\n");
    return 0; /* should never happen with legal SEG-D timestamps, throw exception here */
}

Timestamp utcToTimestamp( const Utc& utc ) {
    int leapIX = isLeap(utc.year) ? 1 : 0; /* february */
    int julian = month_dayToJulian(utc.day,utc.month,leapIX);
    int nd = daysSinceT0(utc.year,julian); /* nd negative if date before 6 jan 1980 */
    Timestamp ts = 1000000*(Timestamp)((Timestamp)nd*24*3600 + utc.hour*3600 + utc.minute*60 + utc.sec) +
        utc.microsec;
    return ts + leapSecs(nd)*1000000;
}

Utc timestampToUtc( Timestamp ts ) {
    Utc result(0,0,0,0,0,0,0);
    int iy, nd, md, im;
    int leapIX;
    Timestamp tsJan1;
    for(iy = 0 ; iy < (sizeof(tsJan1YearArr)/sizeof(tsJan1YearArr[0])); ++iy) {
        if(tsJan1YearArr[iy].timestamp <= ts) {
            result.year = tsJan1YearArr[iy].year;
        } else {
            break;
        }
    }
}

```

```

}
/* if off the end of the charts, return all zeros */
if(result.year == 0) return result;
else tsJan1 = tsJan1YearArr[iy-1].timestamp;

/* reduce to number of microseconds since beginning of year */
ts -= (1000000 * leapSecs(ts));
tsJan1 -= (1000000 * leapSecs(tsJan1));
ts -= tsJan1;

/* extract microseconds */
result.microsec = (int) (ts%1000000);
ts -= result.microsec;
ts /= 1000000;

/* extract seconds */
result.sec = (int) (ts%60);
ts -= result.sec;
ts /= 60;

/* extract minutes */
result.minute = (int) (ts%60);
ts -= result.minute;
ts /= 60;

/* extract hours */
result.hour = (int) (ts%24);
ts /= 24;

/* figure month and day from number of days since start of year */
nd = (int) (ts);
md = 0;
leapIX = isLeap(result.year) ? 1 : 0; /* february */
for( im = 0; im < 12; ++im ) {
    if( md > nd ) break;
    md += dayArr[leapIX][im];
}
result.month = im;
result.day = 1 + nd + dayArr[leapIX][im-1] - md;

if(result.day == 32) { /* leap second */
    result.day = 31; result.hour = 23; result.minute = 59; result.sec = 60;
}

return result;
}

int main(int argc, char **argv)
{
    int yrlist[] = { 1970, 1971, 1972, 1973, 1974, 1975, 1976, 1977, 1978, 1979,
                    1980, 1981, 1982, 1983, 1984, 1985, 1986, 1987, 1988, 1989,
                    1990, 1991, 1992, 1993, 1994, 1995, 1996, 1997, 1998, 1999,
                    2000, 2001, 2002, 2003, 2004, 2005, 2006, 2007, 2008, 2009,
                    2010 };
    int mnlist[] = {
        1, 1, 1, 1, 1, 1, 1, 1, 1, 1, 1,
        1, 1, 1, 1, 1, 1, 1, 1, 1, 1, 1,
        1, 1, 1, 1, 1, 1, 1, 1, 1, 1, 1,
        1, 1, 1, 1, 1, 1, 1, 1, 1, 1, 1,
        1 };

    size_t i;
    Utc testTime(2005,12,31,23,59,60,0);
    Timestamp ts;
    ts = utcToTimestamp(testTime);
    fprintf(stdout,"%s is Timestamp " tsfmt "\n", testTime.toString(), ts);
    testTime = timestampToUtc( ts );
    fprintf(stdout,"%s is Timestamp " tsfmt "\n", testTime.toString(), ts);
    testTime.day = 1;
    testTime.hour = 0;
    testTime.minute = 0;
    testTime.sec = 0;
    testTime.microsec = 0;

    for(i=0; i<(sizeof(yrlist)/sizeof(yrlist[0])); ++i) {

```

```

testTime.year = yrlist[i];
testTime.month = mnlist[i];
fprintf(stdout,"%s is Timestamp " tsfmt "\n", testTime.toString(), utcToTimestamp(testTime));
}
return EXIT_SUCCESS;
}

```

E.10 Electromagnetic (EM) survey

An Electromagnetic survey is acquired using 100 receivers deployed on the sea floor, one source vessel towing a 300m long source and 20 receivers connected to a streamer towed behind the source vessel. This hypothetical controlled source electromagnetic (CSEM) setup is chosen to show all aspects of an EM survey. At the same time magnetotelluric (MT) data will be recorded for all seafloor receivers.

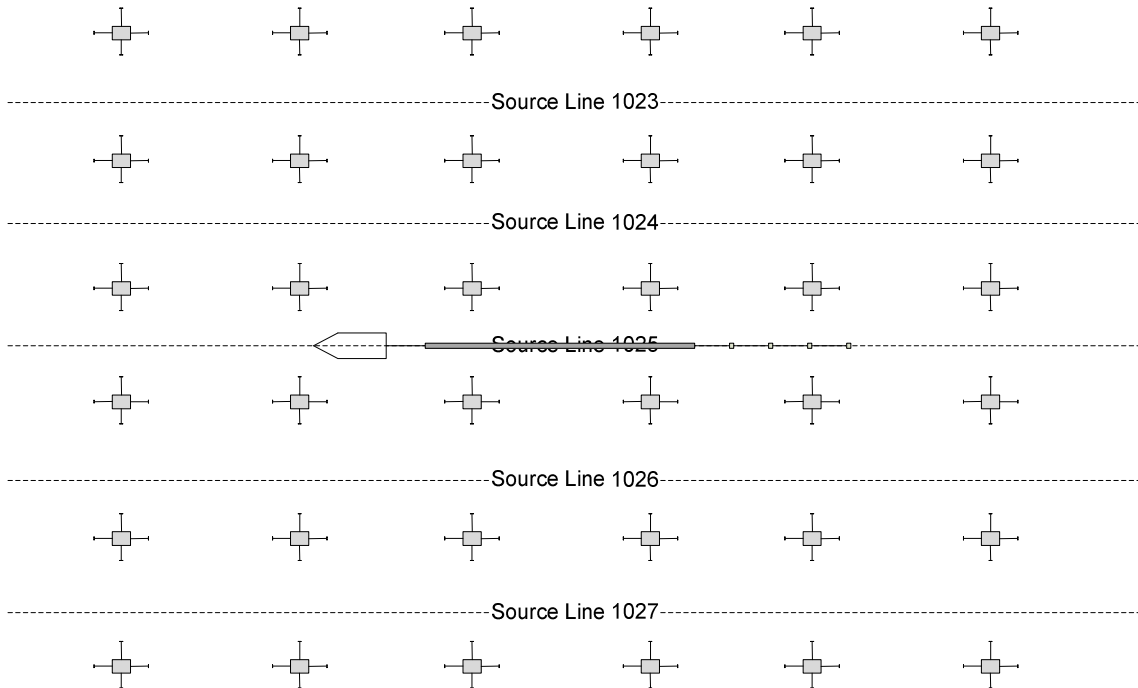

Figure shows a overview of an Electromagnetic survey using EM sensors on the sea floor, and a source vessels with towed sensors behind. Note: The relative sizes between equipment are not correct.

Each seafloor sensor unit consists of 6 different magnetic and electric field sensors, which produces 6 different data traces. The sensor units are completely independent, with no external synchronization while they are deployed. The sensor units acquire data in SEG-D format similar to the example described in E.8 Extended Recording Mode example.

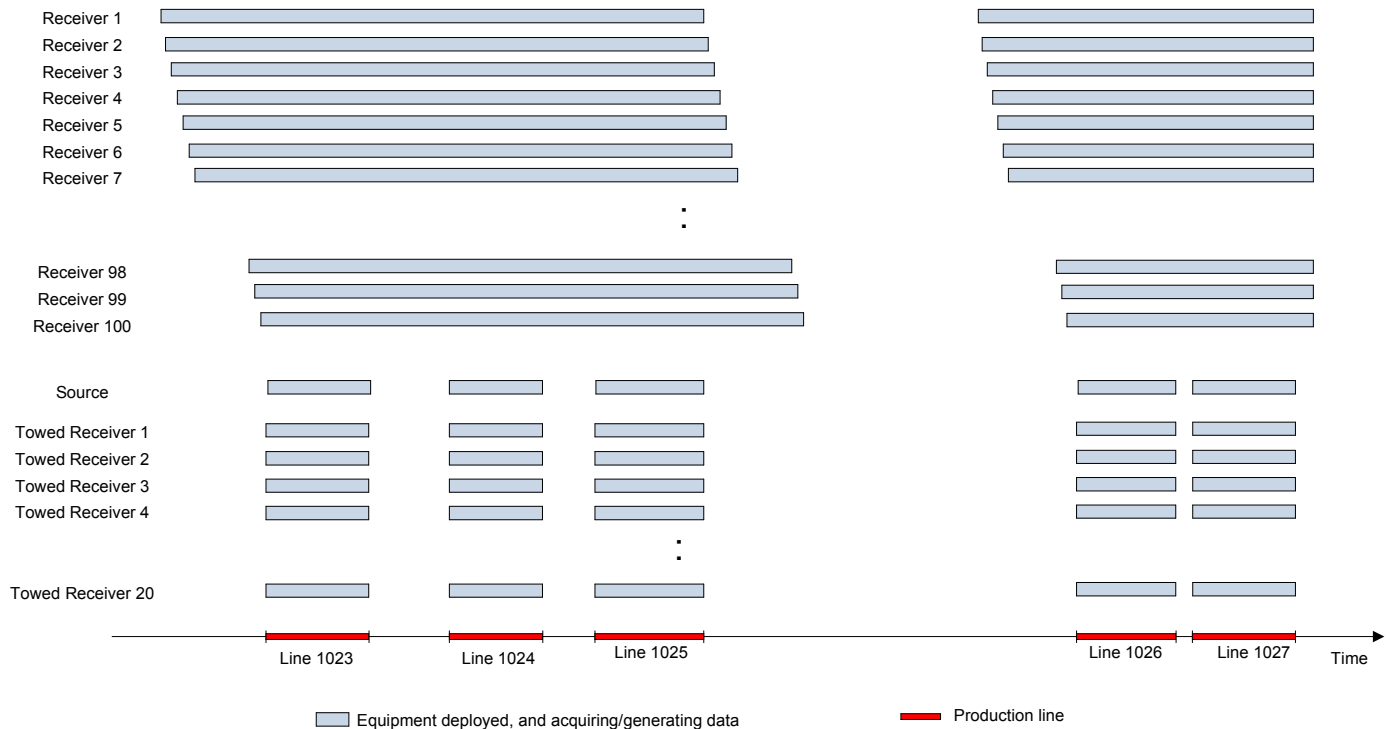

Figure shows an overview of production in an EM survey, with some sensors deployed on the seafloor, and some attached to the source vessel.

The sensors are placed on the sea floor, and data are acquired organized in source lines. After several days the sensors are retrieved, and the data from each sensor unit are read and stored in the acquisition system onboard the vessel as separate files.

Seafloor receiver data:

The raw data records from each seabed sensor unit consists of 6 different channelsets, one for each different channel, recorded as a continuous record using continuous recording mode, splitting traces into 120 second pieces (see E.8 Extended Recording Mode example for further information). As the raw data from each sensor unit is acquired using drifting clocks, the data must be time drift corrected to match GPS time prior to merging with other sensor units.

Towed receiver data:

The data from source and towed receivers are acquired in 18 second normal SEG-D records (which matches the source signal pattern cycle), i.e. each individual SEG-D record contains all source and towed receiver data for 18 seconds. The auxiliary data for the source consists of the reference signal, and a measured signal (electrical field sensor close to the source). The data from the source (auxiliary traces), and the towed sensors are synchronized to GPS as they are acquired, and hence contains no time drift.

The client deliverable will be two datasets:

- *CSEM:* The data will be organized as SEG-D records containing data from all sensors organized into lines similar to a Land/Seabed survey. The EM source emits a continuous signal, so there are no real source events like in standard Marine/Land/Seabed surveys. The source however cycles through a signal pattern which is repeated every 18 seconds, and it is decided to create SEG-D records matching this cycle. Hence, data will be stored as normal SEG-D records each 18 sec long (not using extended recording mode).

- MT:** The data will be organized into SEG-D records containing data from all seabed sensors for a period of time. Since there are no source events, the record size may be arbitrarily chosen, in this example 120 seconds. The data will then be grouped into one record set per day.

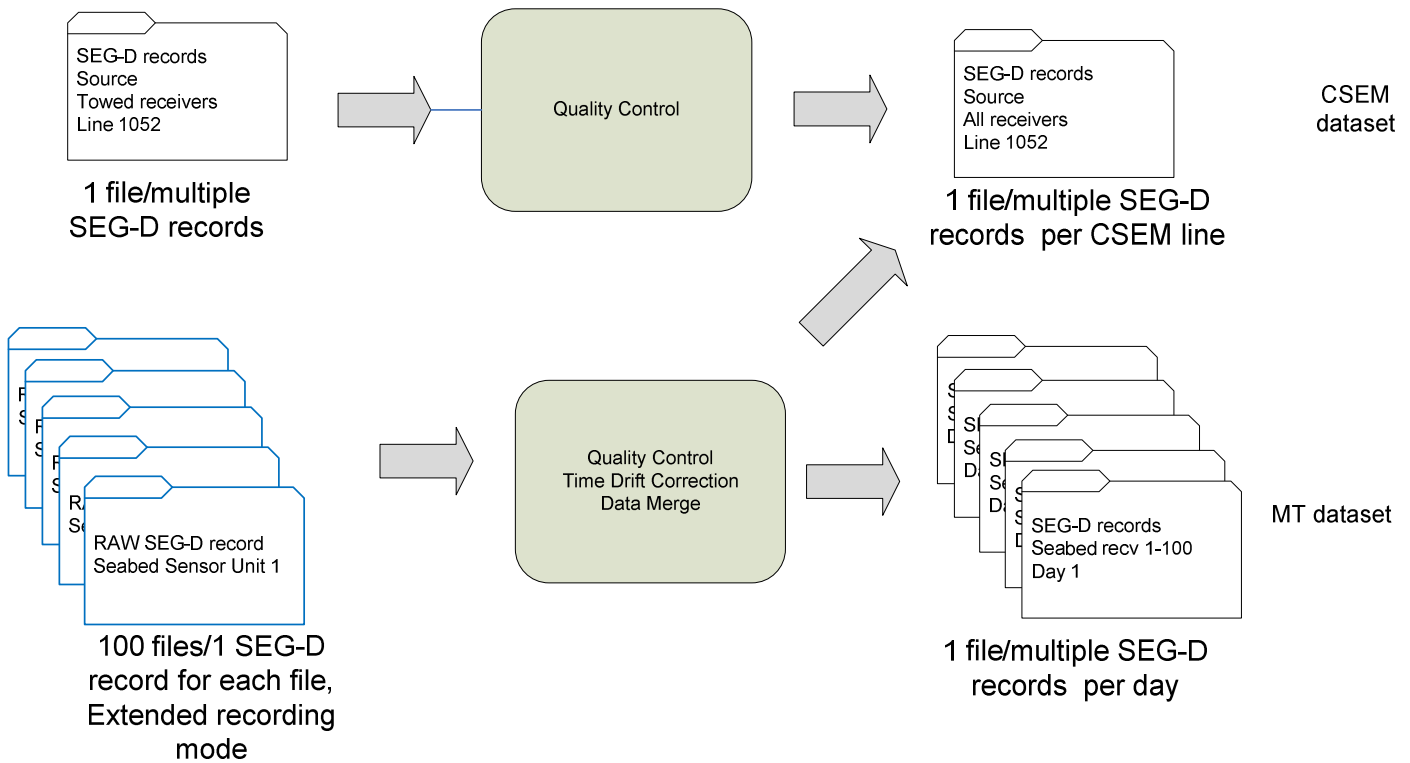

Summary of data flow - extended recording mode records are blue, normal recording mode records are black.

The data from the seafloor sensors are stored in files (one per unit) containing all the data from the entire time the sensor unit was deployed. Before the data from a sensor unit can be merged with other data, it is quality controlled and time drift corrected.

CSEM

For each towline the data is selected from the active sensor unit records based on towline start and end time, and merged with the records from the Source and Towed Receivers. The source data ends up as aux traces. The client deliverable SEG-D record contains data from the source and all sensors for the towline time period.

MT

For MT data, a record will contain all channels for all active receivers. A fixed record length is chosen, in this example 120 seconds, and multiple 120 sec SEG-D records for a given time period (in this example one day) is stored in each disk file. If survey is a combined MT/CSEM survey, there is no need to remove CSEM data from the MT dataset.

Example CSEM SEG-D Block layout.

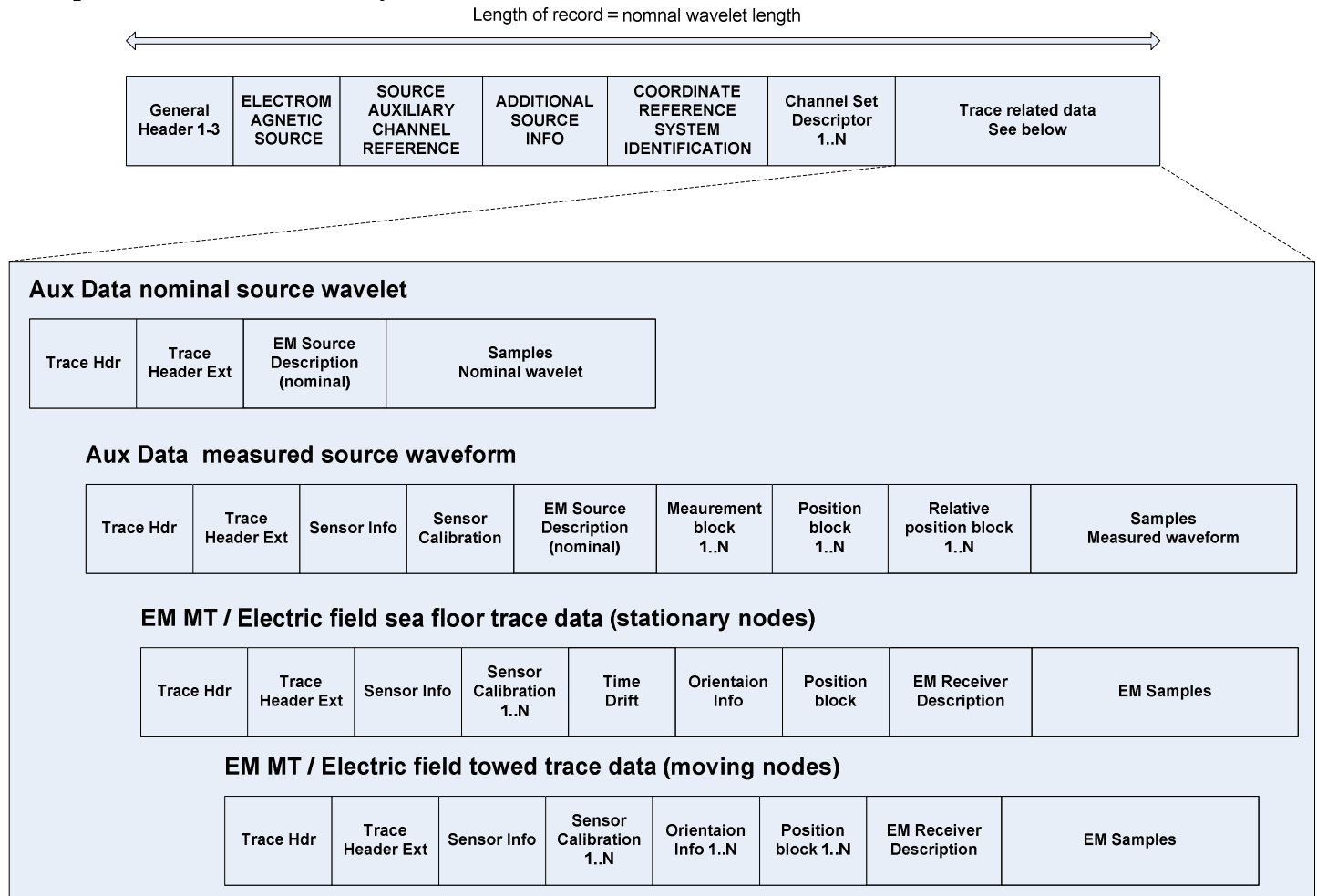

Figure shows CSEM SEG-D record block layout (block sizes are not to scale)

This figure shows how to map EM specific data and header values into SEG-D. A few comments:

- Note that source position will have dipole midpoint in Position block and electrode position in the Relative position blocks.
- Conductivity and other relevant data on the towfish will be in the Measurement blocks.
- The example covers both towed and stationary receivers. The actual selection of block configuration varies between the two situations. The main difference is towed receivers will have multiple position and orientation trace header blocks for the EM traces because the receiver is moving during the record.

E.11 Extended Recording Mode 2

This example deals with a more advanced usage of the Extended Recording mode. The Electromagnetic survey example above (E.10) used Extended Recording mode to acquire data continuously from a sensor, with no connection to external events.

This can be illustrated like this:

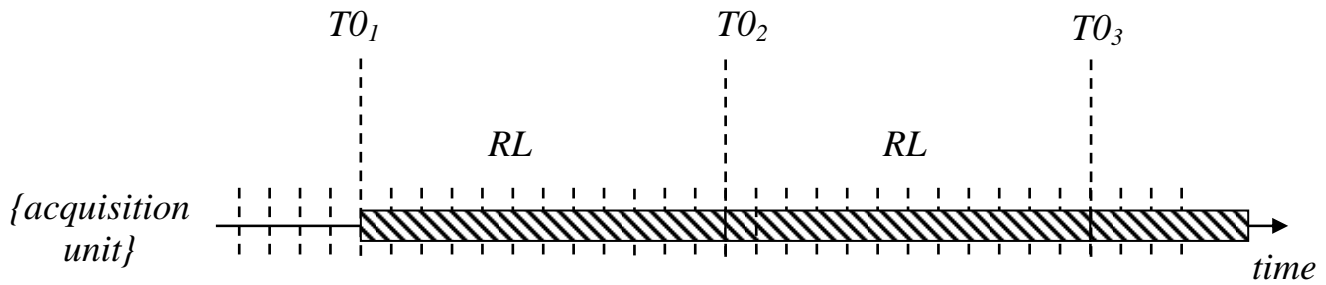

Here $T0_x$ refers to the timestamp (Timestamp block) in each channelset, and the record length RL is the length of each Channel Set. Hence the channel is acquired as one long continuous trace.

Land vibrator survey using autonomous acquisition nodes

Now consider a Land survey using vibrators as sources and a seismic spread consisting of autonomous acquisition nodes.

The individual vibrator acquires an auxiliary trace (base plate movement) every shot, which needs to be stored on the vibrator until the end of the day when it is downloaded. The seismic sensors acquire data for several days before it is picked up and the data downloaded.

The firing time $T0$ is distributed from the vibrators to the acquisition nodes which then records data for a certain time (record length RL). For technical reasons the generation of source firing time is not synchronized with the acquisition sample rate⁸. Also note that the record length of the traces are varying.

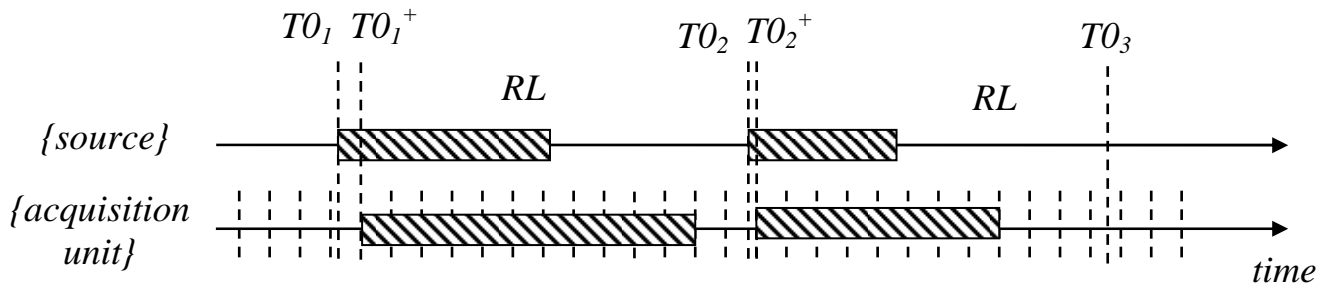

Both source and acquisition nodes will use Extended Recording Mode to store the data. Note there are holes in the data, so the time stamp of the first sample of the next Channel Set is not given by the start of the previous plus the number of samples in it multiplied by the sample rate.

Source

The source records an auxiliary data Channel Set for each shot, and stores the Source Description block, Additional Source Info block and the other source information as part of the Trace Header. (These may also be stored as part of the General Header, but this limits the number of shots possible to store in one record.)

The following table shows the values of some important header fields for the SEG-D record:

⁸ Note it is **highly** recommended to synchronize source firing with the acquisition sample rate as this simplifies the processing of the data. Not doing so also complicates the acquisition as the offset must be detected and recorded (as sample skew or by using timestamp adjustment).

| Byte No. | Fmt | Description | Value | |
|-----------------------------------------------------|------|----------------------------------------------|----------------|--------|
| General Header block #3 (Timestamp and size header) | | | | |
| 1-8 | bin | Time Zero for this record (SEG-D timestamp). | Time of $T0_1$ | |
| 29 | ubin | Extended Recording Mode | 1_{16} | |
| Channel Set Descriptor | | | | |
| 5-8 | bin | Channel set number | 1 | 2 |
| 5-8 | bin | Channel set start time (us) | 0 s | 0 s |
| 9-12 | bin | Channel set end time (us) | 0 s | 0 s |
| 13-16 | bin | Number of Samples | 7000 | 5000 |
| Demultiplexed Trace Header | | | | |
| 7-9 | bin | First Timing Word (1/256 ms) | 0 s | 0 s |
| 11 | ubin | Sample Skew (1/256 of the sampling interval) | 0 | 0 |
| Timestamp Header | | | | |
| 1-8 | bin | Time Zero for this data block | $T0_1$ | $T0_2$ |

Acquisition node

As the acquisition node is not synchronized with the source, the acquisition starts at the next sample after the source event. At least two options exist for how this can be stored

1. Use the time of the timestamp of the following sample as time in Timestamp Header, and leave it to the processing system to detect the skew between source and acquisition node.

| Byte No. | Fmt | Description | Value | |
|-----------------------------------------------------|------|----------------------------------------------|------------------|----------|
| General Header block #3 (Timestamp and size header) | | | | |
| 1-8 | bin | Time Zero for this record (SEG-D timestamp). | Time of $T0_1^+$ | |
| 29 | ubin | Extended Recording Mode | 1_{16} | |
| Channel Set Descriptor | | | | |
| 5-8 | bin | Channel set number | 1 | 2 |
| 5-8 | bin | Channel set start time (us) | 0 s | 0 s |
| 9-12 | bin | Channel set end time (us) | 0 s | 0 s |
| 13-16 | bin | Number of Samples | 11000 | 8000 |
| Demultiplexed Trace Header | | | | |
| 7-9 | bin | First Timing Word (1/256 ms) | 0 s | 0 s |
| 11 | ubin | Sample Skew (1/256 of the sampling interval) | 0 | 0 |
| Timestamp Header | | | | |
| 1-8 | bin | Time Zero for this data block | $T0_1^+$ | $T0_2^+$ |

2. Use the source time in the Timestamp Header block, and use Sample Skew in the trace header to indicate the offset between source and acquisition node.

| Byte No. | Fmt | Description | Value | |
|-----------------------------------------------------|------|----------------------------------------------|----------------|------|
| General Header block #3 (Timestamp and size header) | | | | |
| 1-8 | bin | Time Zero for this record (SEG-D timestamp). | Time of $T0_1$ | |
| 29 | ubin | Extended Recording Mode | 1_{16} | |
| Channel Set Descriptor | | | | |
| 5-8 | bin | Channel set number | 1 | 2 |
| 5-8 | bin | Channel set start time (us) | 0 s | 0 s |
| 9-12 | bin | Channel set end time (us) | 0 s | 0 s |
| 13-16 | bin | Number of Samples | 11000 | 8000 |

| Demultiplexed Trace Header | | | | |
|----------------------------|------|----------------------------------------------|--------|--------|
| 7-9 | bin | First Timing Word (1/256 ms) | 0 s | 0 s |
| 11 | ubin | Sample Skew (1/256 of the sampling interval) | 180 | 50 |
| Timestamp Header | | | | |
| 1-8 | bin | Time Zero for this data block | $T0_1$ | $T0_2$ |

It must be noted that a drawback of option 1 is that the data blocks in the different records do not have the same timestamp (nodes have a different timestamp than the source). The consumer of the data must therefore find the nearest match from all nodes.